

Tank-Mounted Filter

ZT



Features and Benefits

- Low pressure tank-mounted filter
- Available with dual inlet porting
- Offered in pipe, SAE straight thread and ISO 228 porting
- Various Dirt Alarm® options
- Optional PAB1 breather
- Optional dipstick
- **G** Available with quality-protected GeoSeal® Elements (GZT)

40 gpm
150 L/min
100 psi
7 bar

Model No. of filter in photograph is ZT8ZZ10PPESAB.

IRF
 TF1
 KF3
 KL3
 LF1
 MLF1
 RLD
 GRTB
 MTA
 MTB
ZT

Flow Rating:	Up to 40 gpm (150 L/min) for 150 SUS (32 cSt) fluids
Max. Operating Pressure:	100 psi (7 bar)
Min. Yield Pressure:	300 psi (21 bar), per NFPA T2.6.1
Rated Fatigue Pressure:	90 psi (6 bar), per NFPA T2.6.1-R1-2005
Temp. Range:	-20°F to 225°F (-29°C to 107°C)
Bypass Setting:	Cracking: 25 psi (1.7 bar) Full Flow: 39 psi (2.7 bar)
Cap & Bowl:	Nylon
Porting Head:	Aluminum
Weight of ZT-8Z:	3.3 lbs. (1.49 kg)
Element Change Clearance:	10.0" (254 mm)

Filter Housing Specifications

KFT
 RT
 RTI
 LRT
 ART
 BFT
 QT
 KTK
 LTK
 MRT

Type Fluid	Appropriate Schroeder Media
Petroleum Based Fluids	All E media (cellulose) and Z-Media® (synthetic)
High Water Content	All Z-Media (synthetic)
Invert Emulsions	10 and 25 µ Z-Media® (synthetic)
Water Glycols	3, 5, 10 and 25 µ Z-Media® (synthetic)
Phosphate Esters	All Z-Media® (synthetic) with H (EPR) seal designation

Fluid Compatibility

Accessories For Tank-Mounted Filters

PAF1
 MAF1
 MF2

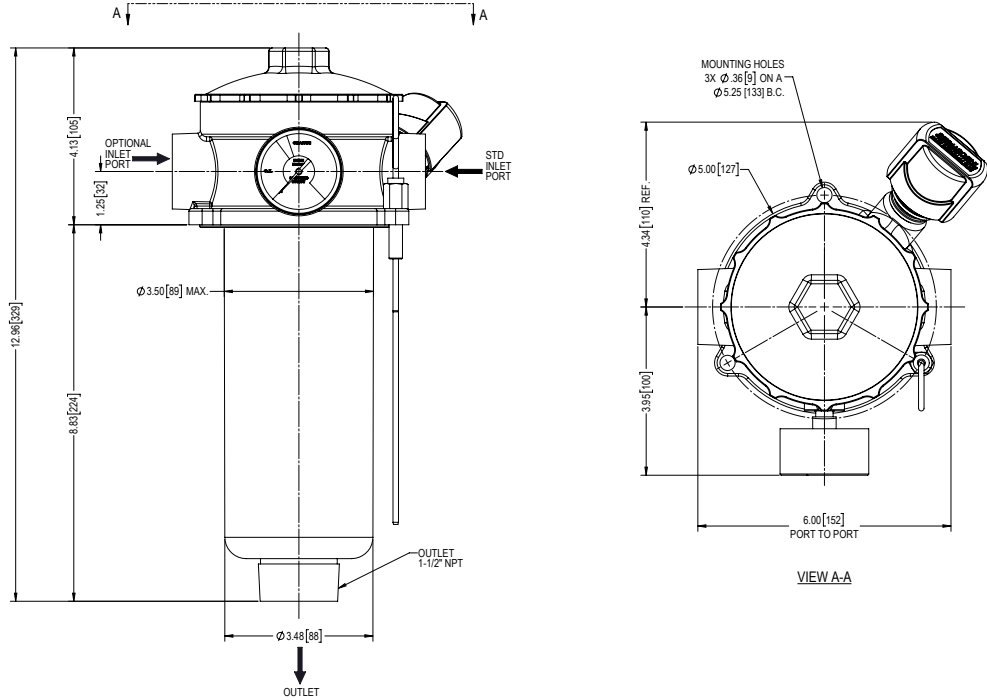

Metric dimensions in ().

Element Performance Information & Dirt Holding Capacity

Element	Filtration Ratio Per ISO 4572/NFPA T3.10.8.8 Using automated particle counter (APC) calibrated per ISO 4402			Filtration Ratio wrt ISO 16889 Using APC calibrated per ISO 11171	
	$\beta_x \geq 75$	$\beta_x \geq 100$	$\beta_x \geq 200$	$\beta_{x(c)} \geq 200$	$\beta_{x(c)} \geq 1000$
8Z3	6.8	7.5	10.0	N/A	N/A
8Z10	15.5	16.2	18.0	N/A	N/A
8ZZ1	<1.0	<1.0	<1.0	<4.0	4.2
8ZZ3	<1.0	<1.0	<2.0	<4.0	4.8
8ZZ5	2.5	3.0	4.0	4.8	6.3
8ZZ10	7.4	8.2	10.0	8.0	10.0
8ZZ25	18.0	20.0	22.5	19.0	24.0

Element	DHC (gm)
8Z3	39
8Z10	32
8ZZ1	51
8ZZ3	52
8ZZ5	59
8ZZ10	55
8ZZ25	77

Element Collapse Rating: 150 psid (10 bar)
 Flow Direction: Outside In
 Element Nominal Dimensions: 3.2" (81 mm) O.D. x 9.25" (235 mm) long

$\Delta P_{\text{housing}}$

ZT $\Delta P_{\text{housing}}$ for fluids with sp gr (specific gravity) = 0.86:

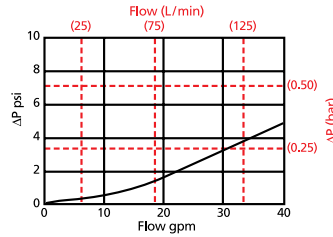

$\Delta P_{\text{element}}$

8ZZ

Element Pressure Drop versus Flow Rate at 32 cSt (150 SUS)

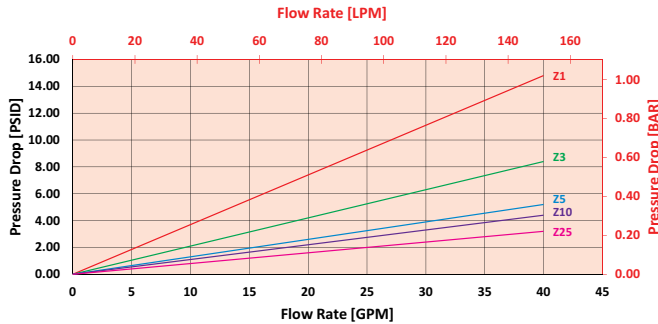

Pressure Drop Information Based on Flow Rate and Viscosity

$$\Delta P_{\text{filter}} = \Delta P_{\text{housing}} + (\Delta P_{\text{element}} * V_f)$$

Exercise:

Determine ΔP_{filter} at 30 gpm (119.7 L/min) for ZT8ZZ10SY2 using 160 SUS (34 cSt) fluid.

Use the housing pressure curve to determine $\Delta P_{\text{housing}}$ at 30 gpm. In this case, $\Delta P_{\text{housing}}$ is 3.5 psi (.24 bar) on the graph for the ZT housing.

Use the element pressure curve to determine $\Delta P_{\text{element}}$ at 30 gpm. In this case, $\Delta P_{\text{element}}$ is 3.5 psi (.24 bar) according to the graph for the 8ZZ10 element.

Because the viscosity in this sample is 160 SUS (34 cSt), we determine the **Viscosity Factor (V_f)** by dividing the **Operating Fluid Viscosity** with the **Standard Viscosity** of 150 SUS (32 cSt). To best determine your Operating Fluid Viscosity, please reference the chart in Appendix D.

Finally, the overall filter pressure differential, ΔP_{filter} , is calculated by adding $\Delta P_{\text{housing}}$ with the true element pressure differential, ($\Delta P_{\text{element}} * V_f$). The $\Delta P_{\text{element}}$ from the graph has to be multiplied by the viscosity factor to get the true pressure differential across the element.

Solution:

$\Delta P_{\text{housing}} = 3.5 \text{ psi } [.24 \text{ bar}] \mid \Delta P_{\text{element}} = 3.5 \text{ psi } [.24 \text{ bar}]$

$V_f = 160 \text{ SUS } (34 \text{ cSt}) / 150 \text{ SUS } (32 \text{ cSt}) = 1.1$

$\Delta P_{\text{filter}} = 3.5 \text{ psi} + (3.5 \text{ psi} * 1.1) = 7.4 \text{ psi}$

OR

$\Delta P_{\text{filter}} = .24 \text{ bar} + (.24 \text{ bar} * 1.1) = .50 \text{ bar}$

Note:

If your element is not graphed, use the following equation:

$\Delta P_{\text{element}} = \text{Flow Rate} \times \Delta P_f$. Plug this variable into the overall pressure drop equation.

Ele.	ΔP
8Z3	0.25
8Z10	0.09
8Z25	0.02

Filter Model Number Selection

How to Build a Valid Model Number for a Schroeder ZT:

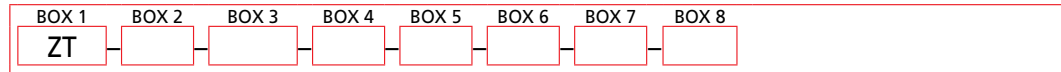

Example: NOTE: One option per box

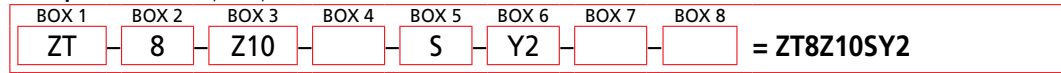

BOX 1	BOX 2	BOX 3	BOX 4
Filter Series	Element Length (in)	Element Size and Media	Seal Material
ZT GZT (GeoSeal®)	8	<p>Z3 = Z size 3 μ E media (cellulose)</p> <p>Z10 = Z size 10 μ E media (cellulose)</p> <p>Z25 = Z size 25 μ E media (cellulose)</p> <p>ZZ1 = Z size 1 μ Excellement® Z-Media® (synthetic)</p> <p>ZZ3 = Z size 3 μ Excellement® Z-Media® (synthetic)</p> <p>ZZ5 = Z size 5 μ Excellement® Z-Media® (synthetic)</p> <p>ZZ10 = Z size 10 μ Excellement® Z-Media® (synthetic)</p> <p>ZZ25 = Z size 25 μ Excellement® Z-Media® (synthetic)</p> <p>GeoSeal® Element Options</p> <p>GZ3 = Z size 3 μ E media (cellulose)</p> <p>GZ10 = Z size 10 μ E media (cellulose)</p> <p>GZ25 = Z size 25 μ E media (cellulose)</p> <p>GTZZ1 = Z size 1 μ Excellement® Z-Media® (synthetic)</p> <p>GTZZ3 = Z size 3 μ Excellement® Z-Media® (synthetic)</p> <p>GTZZ5 = Z size 5 μ Excellement® Z-Media® (synthetic)</p> <p>GTZZ10 = Z size 10 μ Excellement® Z-Media® (synthetic)</p> <p>GTZZ25 = Z size 25 μ Excellement® Z-Media® (synthetic)</p>	Omit = Buna N H = EPR

BOX 5	BOX 6
Inlet Porting	Dirt Alarm® Options
<p>P = 1" NPTF</p> <p>PP = Dual 1" NPTF</p> <p>S = SAE-16</p> <p>SS = Dual SAE-16</p> <p>B = ISO 228 G-1"</p> <p>BB = Dual ISO 228 G-1"</p>	<p>Omit = None</p> <p>Visual</p> <p>Y2 = Back-mounted tri-color gauge</p> <p>Y2C = Bottom-mounted gauge in cap</p> <p>Y5 = Back-mounted gauge in cap</p> <p>Electrical</p> <p>ES = Electric switch</p> <p>ES1 = Heavy-duty electric switch with conduit connection</p>

BOX 7	BOX 8
Outlet Porting Options	Options
<p>Omit = 1½" NPT male</p> <p>C = Check valve</p> <p>D = Diffuser</p> <p>CD = Check valve & diffuser</p> <p>T = 13" Tube extension</p>	<p>Omit = None</p> <p>G3039 = 1.5" NPT Outlet Removed</p> <p>A = Dipstick</p> <p>B = Breather</p> <p>AB = Dipstick & Breather</p> <p>D = Diffuser</p> <p>M = Mounting Gasket (Buna N)</p>