













Section 5:
up to 500 psi

LOW PRESSURE FILTERS

Section 5

Low Pressure Filters Selection Guide

		Pressure psi (bar)	Flow gpm (L/ min)	Element Length/Size	Page	
Low Pressure Filters (up to 500 psi)	Top-Ported Low Pressure Filters					
	IRF	100 (7)	100 (380)	K, KK, KD, KKD	217	
	TF1	300 (20)	30 (120)	A	221	
	KF3 	300 (20)	100 (380)	K, KK, 27K	225	
	KL3 	300 (20)	120 (455)	K, KK, 27K, 18LC	229	
	LF1-2"	300 (20)	120 (455)	18LC	233	
	MLF1 	300 (20)	200 (760)	K	237	
	RLD	350 (24)	100 (380)	25DN, 40D	241	
	Tank-Mounted (In-Tank/Tank Top) Low Pressure Filters					
	GRTB 	100 (7)	100 (380)	KBG	245	
	MTA	100 (7)	15 (55)	3TA	249	
	MTB	100 (7)	35 (135)	3TB, 5TB	253	
	ZT 	100 (7)	40 (150)	8Z	257	
	AFT 	100 (7)	40 (151)	4LK, 8LK	261	
	KFT 	100 (7)	100 (380)	K, KK, KD, KKD, 27K	265	
	RT 	100 (7)	100 (380)	K, KK, KD, KKD, 27K	269	
	RTI	100 (7)	120 (455)	KI, KKI, 27KI	273	
	LRT 	100 (7)	150 (570)	18L, 18LD	277	
	ART	145 (10)	225 (850)	85Z1, 85Z3, 85Z5, 85Z10, 85Z25	281	
	BRT 	145 (10)	160 (600)	2RBZ10/25, 3RBZ10/25, 4RBZ10/25, 6RBZ10/25	285	
	TRT 	145 (10)	634 (2400)	2RTZ10/25, 3RTZ10/25, 4RTZ10/25, 6RTZ10/25	291	
	BFT	100 (7)	300 (1135)	BB	297	
	QT	100 (7)	450 (1700)	16Q, 16QPML, 39Q, 39QPML	301	
	Special Feature Tank-Mounted Low Pressure Filters					
	Internal	KTK 	100 (7)	100 (380)	K, KK, 27K	305
	Internal	LTK	100 (7)	150 (570)	18L	309
	Severe Duty Tank-Mounted					
		MRT	900 (62)	150 (570)	18L	313
Spin-On Low Pressure Filters						
	PAF1	100 (7)	20 (75)	6P	319	
	MAF1	100 (7)	50 (190)	M, 10M	323	
	MF2	150 (10)	60 (230)	M, 10M	327	

Inline Return Filter

IRF

IRF



Features and Benefits

- Low pressure top servicing in-line filter
- Meets HF4 automotive standard
- Unique side mounting flange provides reliable seal arrangement between head and bowl
- The use of K-size elements allows consolidation of inventoried replacement elements
- Single and double length options provide optimal size for specific applications
- Also available with new DirtCatcher® elements (KDZ and KKDZ)
- Various Dirt Alarm® options

100 gpm
380 L/min
100 psi
7 bar

Model No. of filter in photograph is IRF2KZ10S20Y2.

TF1

KF3

KL3

LF1

MLF1

RLD

GRTB

MTA

MTB

ZT

AFT

KFT

RT

RTI

LRT

ART

BRT

TRT

BFT

QT

KTK

LTK

MRT

Flow Rating:	Up to 100 gpm (380 L/min) for 150 SUS (32 cSt) fluids
Max. Operating Pressure:	100 psi (7 bar)
Min. Yield Pressure:	400 psi (28 bar), per NFPA T2.6.1
Rated Fatigue Pressure:	90 psi (6 bar), per NFPA T2.6.1-2005
Temp. Range:	-20°F to 225°F (-29°C to 107°C)
Bypass Setting:	Cracking: 25 psi (1.7 bar) Full Flow: 48 psi (3.3 bar)
Porting Head:	Sand Cast Aluminum
Element Case:	Steel
Weight of IRF-1K:	13.5 lbs. (6.12 kg)
Weight of IRF-2K:	17.0 lbs. (7.71 kg)
Element Change Clearance:	8.0" (205 mm) for 1K; 17.50" (445 mm) for KK

Filter Housing Specifications

Type Fluid	Appropriate Schroeder Media
Petroleum Based Fluids	All E media (cellulose), Z-Media® and ASP® media (synthetic)
High Water Content	All Z-Media® and ASP® media (synthetic)
Invert Emulsions	10 and 25 µ Z-Media® (synthetic), 10 µ ASP® media (synthetic)
Water Glycols	3, 5, 10 and 25 µ Z-Media® (synthetic), 3, 5, and 10 µ ASP® media (synthetic)
Phosphate Esters	All Z-Media® (synthetic) with H (EPR) seal designation and 3 and 10 µ E media (cellulose) with H (EPR) seal designation and all ASP® Media (synthetic)
Skydrol®	3, 5, 10 and 25 µ Z-Media® (synthetic) with H.5 seal designation (EPR seals and stainless steel wire mesh in element, and light oil coating on housing exterior) and all ASP® media (synthetic)

Fluid Compatibility

Accessories For Tank-Mounted Filters

PAF1

MAF1

MF2

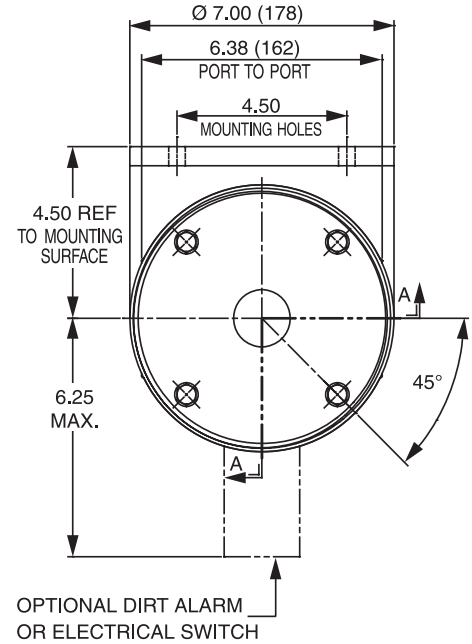
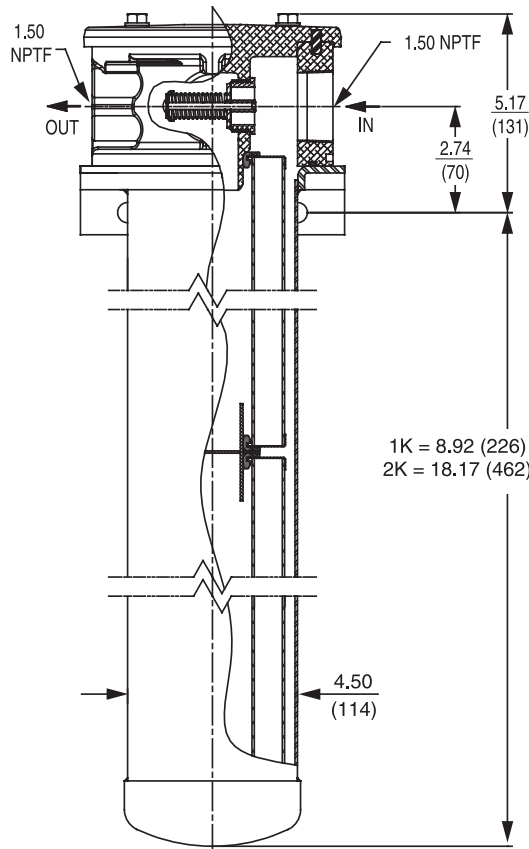

Metric dimensions in ().

Element Performance Information & Dirt Holding Capacity

Element	Filtration Ratio Per ISO 4572/NFPA T3.10.8.8 Using automated particle counter (APC) calibrated per ISO 4402			Filtration Ratio per ISO 16889 Using APC calibrated per ISO 11171	
	$\beta_x \geq 75$	$\beta_x \geq 100$	$\beta_x \geq 200$	$\beta_x(c) \geq 200$	$\beta_x(c) \geq 1000$
KZ1/KKZ1/27KZ1	<1.0	<1.0	<1.0	<4.0	4.2
KZ3/KKZ3	<1.0	<1.0	<2.0	<4.0	4.8
KZ5/KKZ5	2.5	3.0	4.0	4.8	6.3
KZ10/KKZ10	7.4	8.2	10.0	8.0	10.0
KZ25/KKZ25/27KZ25	18.0	20.0	22.5	19.0	24.0
KZW1	N/A	N/A	N/A	<4.0	<4.0
KZW3/KKZW3	N/A	N/A	N/A	4.0	4.8
KZW5/KKZW5	N/A	N/A	N/A	5.1	6.4
KZW10/KKZW10	N/A	N/A	N/A	6.9	8.6
KZW25/KKZW25	N/A	N/A	N/A	15.4	18.5

Element	DHC (g)	Element	DHC (g)	Element	DHC (g)	Element	DHC (g)	Element	DHC (g)	Element	DHC (g)
KZ1	112	KKZ1	224	27KZ1	336	KDZ1	89	KKDZ1	188	KZW1	61
KZ3	115	KKZ3	230	27KZ3	345	KDZ3	71	KKDZ3	150	KZW3	64
KZ5	119	KKZ5	238	27KZ5	357	KDZ5	100	KKDZ5	210	KZW5	63
KZ10	108	KKZ10	216	27KZ10	324	KDZ10	80	KKDZ10	168	KZW10	57
KZ25	93	KKZ25	186	27KZ25	279	KDZ25	81	KKDZ25	171	KZW25	79
										KKZW3	128
										KKZW5	126
										KKZW10	114
										KKZW25	158

Element Collapse Rating: 150 psid (10 bar) for standard elements
 Flow Direction: Outside In
 Element Nominal Dimensions:
 K: 3.9" (99 mm) O.D. x 9.0" (230 mm) long
 KK: 3.9" (99 mm) O.D. x 18.0" (460 mm) long
 27K: 3.9" (99 mm) O.D. x 27.0" (690 mm) long

$\Delta P_{\text{housing}}$

IRF $\Delta P_{\text{housing}}$ for fluids with sp gr (specific gravity) = 0.86:

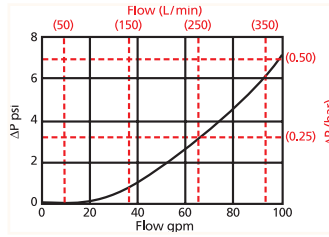

$\Delta P_{\text{element}}$

1KZ

Element Pressure Drop versus Flow Rate at 32 cSt (150 SUS)

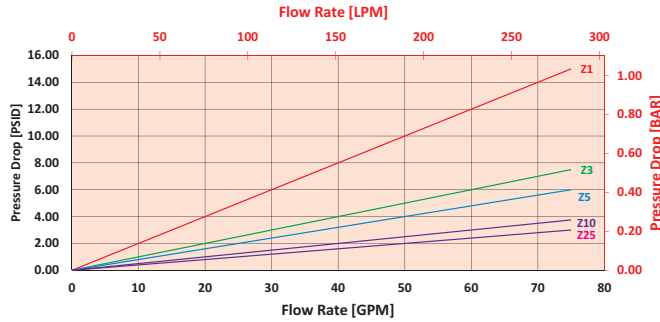

2KZ/KKZ

Element Pressure Drop versus Flow Rate at 32 cSt (150 SUS)

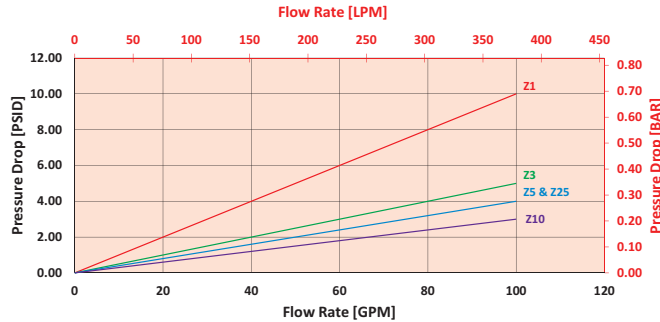

$$\Delta P_{\text{filter}} = \Delta P_{\text{housing}} + (\Delta P_{\text{element}} * V_f)$$

Exercise:

Determine ΔP_{filter} at 70 gpm (265.3 L/min) for IRF2KZ10S20Y2 using 160 SUS (34 cSt) fluid.

Use the housing pressure curve to determine $\Delta P_{\text{housing}}$ at 70 gpm. In this case, $\Delta P_{\text{housing}}$ is 3.5 psi (.24 bar) on the graph for the IRF housing.

Use the element pressure curve to determine $\Delta P_{\text{element}}$ at 70 gpm. In this case, $\Delta P_{\text{element}}$ is 2 psi (.14 bar) according to the graph for the 2KZ10 element.

Because the viscosity in this sample is 160 SUS (24 cSt), we determine the Viscosity Factor (V_f) by dividing the Operating Fluid Viscosity with the Standard Viscosity of 150 SUS (32 cSt). To best determine your Operating Fluid Viscosity, please reference the chart in Appendix D.

Finally, the overall filter pressure differential, ΔP_{filter} , is calculated by adding $\Delta P_{\text{housing}}$ with the true element pressure differential, $(\Delta P_{\text{element}} * V_f)$. The $\Delta P_{\text{element}}$ from the graph has to be multiplied by the viscosity factor to get the true pressure differential across the element.

Solution:

$\Delta P_{\text{housing}} = 3.5 \text{ psi } [.24 \text{ bar}] \mid \Delta P_{\text{element}} = 2 \text{ psi } [.14 \text{ bar}]$

$V_f = 160 \text{ SUS (34 cSt)} / 150 \text{ SUS (32 cSt)} = 1.1$

$\Delta P_{\text{filter}} = 3.5 \text{ psi} + (2 \text{ psi} * 1.1) = 5.7 \text{ psi}$

OR

$\Delta P_{\text{filter}} = .24 \text{ bar} + (.14 \text{ bar} * 1.1) = .39 \text{ bar}$

Pressure Drop Information Based on Flow Rate and Viscosity

Note: If your element is not graphed, use the following equation:
 $\Delta P_{\text{element}} = \text{Flow Rate} \times \Delta P_f$. Plug this variable into the overall pressure drop equation.

Ele.	ΔP	Ele.	ΔP
K3	0.25	2K3	0.12
K10	0.09	2K10	0.05
K25	0.02	2K25	0.01
KAS3	0.10	2KAS3	0.05
KAS5	0.08	2KAS5	0.04
KAS10	0.05	2KAS10	0.03
KDZ1	0.24	2KDZ1	0.12
KDZ3	0.12	2KDZ3	.06
KDZ5	0.10	2KDZ5	0.05
KDZ10	0.06	2KDZ10	0.03
KDZ25	0.04	2KDZ25	0.02
KZW1	0.43	2KZW1	-
KZW3	0.32	2KZW3	0.16
KZW5	0.28	2KZW5	0.14
KZW10	0.23	2KZW10	0.12
KZW25	0.14	2KZW25	0.07

Filter Model Number Selection

How to Build a Valid Model Number for a Schroeder IRF:

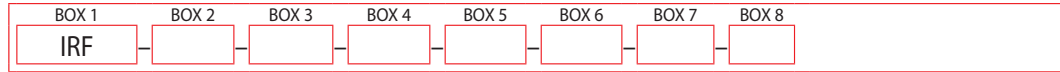

Example: NOTE: One option per box

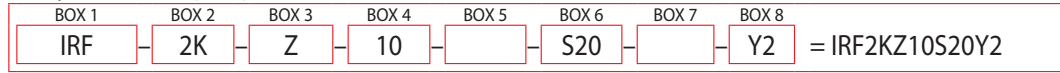

BOX 1	BOX 2	BOX 3
Filter Series	Number and Size of Elements	Element Type
IRF	1 = K, KK 2 = K	Omit = E media (cellulose) AS = Anti-Static Pleat Media Z = Excellement® Z-Media® (synthetic) ZW = Aqua-Excellement® ZW media W = Water Removal media M = M media (reusable metal) DZ = DirtCatcher® Excellement® Z-Media®

BOX 4	BOX 5	BOX 6
Micron Rating	Seal Material	Inlet Porting
1 = 1 μ (Z, ZW and DZ media) 3 = 3 μ (E, AS, Z, ZW and DZ media) 5 = 5 μ (AS, Z, ZW and DZ media) 10 = 10 μ (E, AS, Z, ZW and DZ media) 25 = 25 μ (E, AS, Z, ZW and DZ media) 60 = 60 μ (M media)	Omit = Buna N H = EPR V = Viton®	P16 = 1" NPTF P20 = 1¼" NPTF S16 = SAE-16 S20 = SAE-20 F20 = 1¼" SAE 4-bolt flange Code 61 F24 = 1½" SAE 4-bolt flange Code 61 B24 = ISO 228 G-1½"

BOX 7	BOX 8
Bypass Setting	Dirt Alarm® Options
Omit = 25 PSI Bypass 40 = 40 PSI Bypass	Omit = None Visual Y2 = Back-mounted tri-color gauge ES = Electrical switch ES1 = Heavy-duty electrical switch with conduit connector ES2 = Electrical Switch with Deutsch Connector Visual Y2R = Back-mounted gauge mounted on opposite side of standard location ESR = Electrical switch mounted on opposite side of standard location ES1R = Heavy-duty electrical switch with conduit connector
	Located @ Port D (Standard) Located @ Port C (Optional)

NOTES:

- Box 2. Number of elements must equal 1 when using KK elements.
- Box 3. Replacement element part numbers are identical to contents of Boxes 2, 3, 4, and 5. Double stacking of K-size elements can be replaced by single KK elements.
- Box 5. Viton® is a registered trademark of DuPont Dow Elastomers.

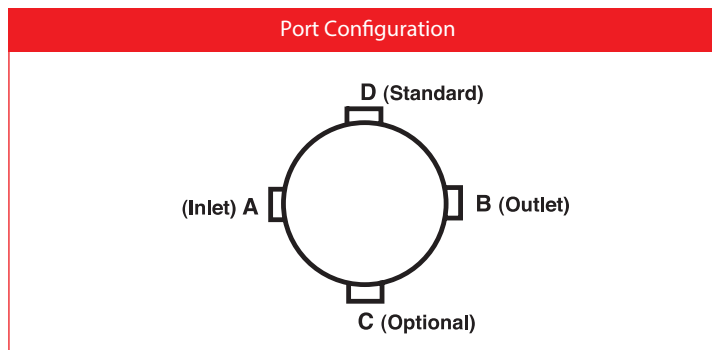

Return Line Filter

TF1

IRF

TF1



Features and Benefits

- Offered in pipe, SAE straight thread, flange and ISO 228 porting
- Various Dirt Alarm® options
- Available with No-Element indicator
- Available with NPTF inlet and outlet female test ports
- Available with magnet inserts
- Available with housing drain plug

30 gpm
120 L/min
 300 psi
 20 bar

KF3

KL3

LF1

MLF1

RLD

GRTB

MTA

MTB

ZT

AFT

KFT

RT

RTI

LRT

ART

BRT

TRT

BFT

QT

KTK

LTK

MRT

Model No. of filter in photograph is TF11AZ10S.

Flow Rating:	Up to 30 gpm (120 L/min) for 150 SUS (32 cSt) fluids
Max. Operating Pressure:	300 psi (20 bar)
Min. Yield Pressure:	1200 psi (80 bar), per NFPA T2.6.1
Rated Fatigue Pressure:	270 psi (19 bar), per NFPA T2.6.1-2005
Temp. Range:	-20°F to 225°F (-29°C to 107°C)
Bypass Setting:	Cracking: 30 psi (2 bar) Full Flow: 51 psi (4 bar)
Porting Head:	Cast Aluminum
Element Case:	Steel (TF1) or Stainless Steel (WTF1)
Weight of TF1-1A:	5.1 lbs. (2.3 kg)
Weight of TF1-2A:	6.3 lbs. (2.9 kg)
Element Change Clearance:	3.50" (90 mm)

Filter Housing Specifications

Type Fluid	Appropriate Schroeder Media
Petroleum Based Fluids	All E media (cellulose) and Z-Media® (synthetic)
High Water Content	All Z-Media® (synthetic)
Invert Emulsions	10 and 25 µ Z-Media® (synthetic)
Water Glycols	3, 5, 10 and 25 µ Z-Media® (synthetic)
Phosphate Esters	All Z-Media® (synthetic) with H (EPR) seal designation
Skydrol®	3, 5, 10 and 25 µ Z-Media® (synthetic) with H.5 seal designation (EPR seals and stainless steel wire mesh in element, and light oil coating on housing exterior)

Fluid Compatibility

Accessories For Tank-Mounted Filters

PAF1

MAF1

MF2

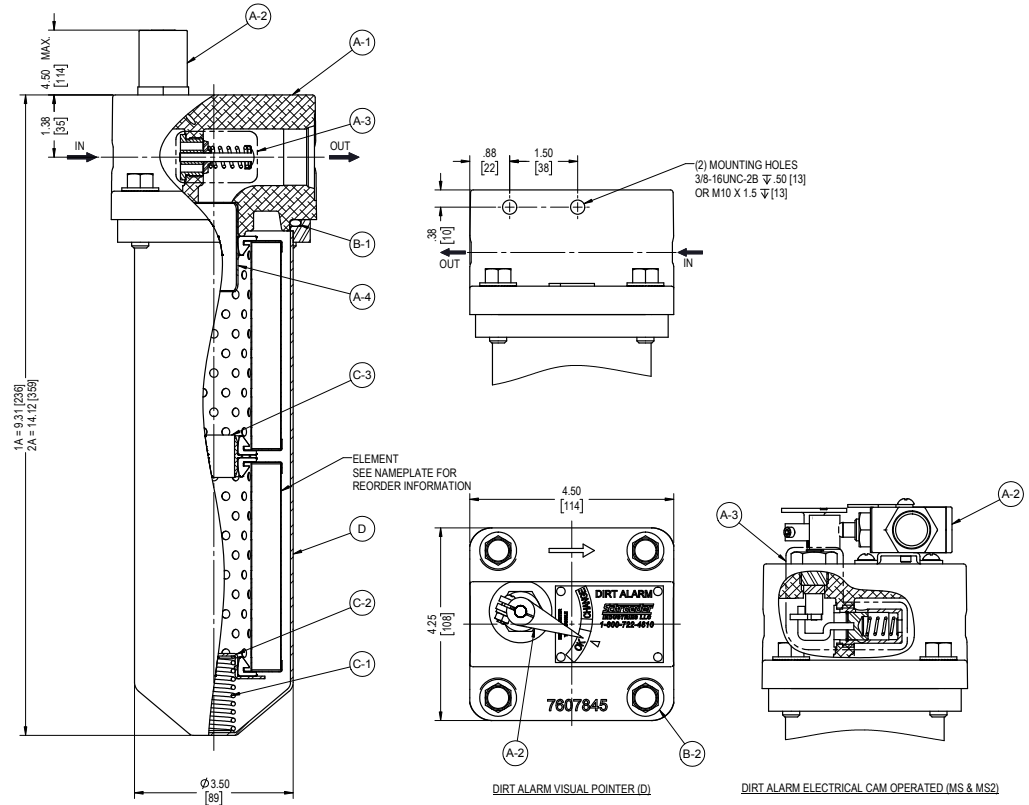

Metric dimensions in ().

Element Performance Information & Dirt Holding Capacity

Element	Filtration Ratio Per ISO 4572/NFPA T3.10.8.8 Using automated particle counter (APC) calibrated per ISO 4402			Filtration Ratio per ISO 16889 Using APC calibrated per ISO 11171	
	$\beta_x \geq 75$	$\beta_x \geq 100$	$\beta_x \geq 200$	$\beta_{x(c)} \geq 200$	$\beta_{x(c)} \geq 1000$
AZ1	<1.0	<1.0	<1.0	<4.0	4.2
AZ3	<1.0	<1.0	<2.0	<4.0	4.8
AZ5	2.5	3.0	4.0	4.8	6.3
AZ10	7.4	8.2	10.0	8.0	10.0
AZ25	18.0	20.0	22.5	19.0	24.0

Element	DHC (gm)
A3	16
A10	13
AZ1	25
AZ3	26
AZ5	30
AZ10	28
AZ25	28

Element Collapse Rating: 150 psid (10 bar)

Flow Direction: Outside In

Element Nominal Dimensions: 3.0" (75 mm) O.D. x 4.5" (115 mm) long

$\Delta P_{\text{housing}}$

TF1 $\Delta P_{\text{housing}}$ for fluids with sp gr (specific gravity) = 0.86:

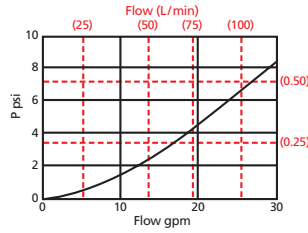

Pressure Drop Information Based on Flow Rate and Viscosity

$\Delta P_{\text{element}}$

AZ

Element Pressure Drop versus Flow Rate at 32 cSt (150 SUS)

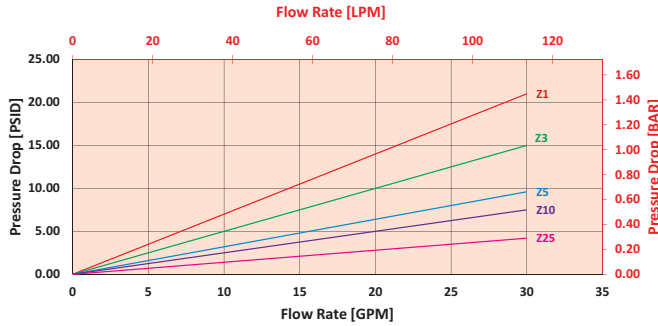

2AZ

Element Pressure Drop versus Flow Rate at 32 cSt (150 SUS)

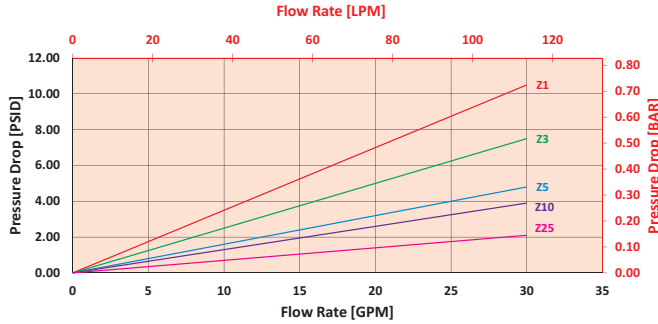

$$\Delta P_{\text{filter}} = \Delta P_{\text{housing}} + (\Delta P_{\text{element}} * V_f)$$

Exercise:

Determine ΔP_{filter} at 15 gpm (57 L/min) for TF11AZ3PD5 using 175 SUS (37.2 cSt) fluid.

Use the housing pressure curve to determine $\Delta P_{\text{housing}}$ at 15 gpm. In this case, $\Delta P_{\text{housing}}$ is 3 psi (.21 bar) on the graph for the TF1 housing.

Use the element pressure curve to determine $\Delta P_{\text{element}}$ at 15 gpm. In this case, $\Delta P_{\text{element}}$ is 7.5 psi (.52 bar) according to the graph for the AZ3 element.

Because the viscosity in this sample is 175 SUS (37.2 cSt), we determine the Viscosity Factor (V_f) by dividing the Operating Fluid Viscosity with the Standard Viscosity of 150 SUS (32 cSt). To best determine your Operating Fluid Viscosity, please reference the chart in Appendix D.

Finally, the overall filter pressure differential, ΔP_{filter} , is calculated by adding $\Delta P_{\text{housing}}$ with the true element pressure differential, ($\Delta P_{\text{element}} * V_f$). The $\Delta P_{\text{element}}$ from the graph has to be multiplied by the viscosity factor to get the true pressure differential across the element.

Solution:

$\Delta P_{\text{housing}} = 3 \text{ psi } [.21 \text{ bar}] \mid \Delta P_{\text{element}} = 7.5 \text{ psi } [.52 \text{ bar}]$

$V_f = 175 \text{ SUS } (37.2 \text{ cSt}) / 150 \text{ SUS } (32 \text{ cSt}) = 1.2$

$\Delta P_{\text{filter}} = 3 \text{ psi} + (7.5 \text{ psi} * 1.2) = 12 \text{ psi}$

OR

$\Delta P_{\text{filter}} = .21 \text{ bar} + (.52 \text{ bar} * 1.2) = .83 \text{ bar}$

Note:

If your element is not graphed, use the following equation:
 $\Delta P_{\text{element}} = \text{Flow Rate} \times \Delta P_f$ Plug this variable into the overall pressure drop equation.

Ele.	ΔP	Ele.	ΔP
A3	0.53	AA3	0.27
A10	0.36	AA10	0.18
A25	0.05	AA25	0.03

Filter Model Number Selection

How to Build a Valid Model Number for a Schroeder TF1:

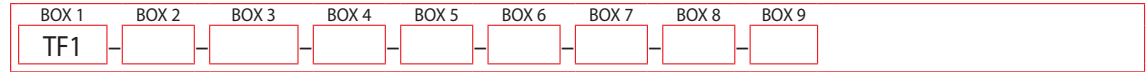

Example: NOTE: Only box 9 may contain more than one option

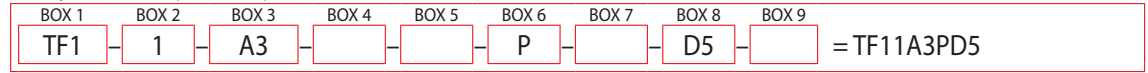

BOX 1	BOX 2	BOX 3	BOX 4	BOX 5
Filter Series	Number of Elements	Element Part Number	Seal Material	Magnet Option
TF1	1 2	A3 = 3 μ E media (cellulose) A10 = 10 μ E media (cellulose) A25 = 25 μ E media (cellulose) AZ1 = 1 μ Excellement® Z-Media® (synthetic) AZ3 = 3 μ Excellement® Z-Media® (synthetic) AZ5 = 5 μ Excellement® Z-Media® (synthetic) AZ10 = 10 μ Excellement® Z-Media® (synthetic) AZ25 = 25 μ Excellement® Z-Media® (synthetic) AM10 = 10 μ M media (reusable metal) AM25 = 25 μ M media (reusable metal) AM60 = 60 μ M media (reusable metal) AM150 = 150 μ M media (reusable metal)	Omit = Buna N H = EPR V = Viton® H.5 = Skydrol® compatibility	Omit = None M = Magnet inserts
WTF1				

BOX 6	BOX 7	BOX 8	BOX 9
Porting Options	Bypass Settings	Dirt Alarm® Options	Test Points
P = 1" NPTF S = SAE-16 B = ISO 228 G-1"	Omit = 30 psi bypass 40 = 40 psi bypass	Omit = None Visual D = Pointer D5 = Visual pop-up Visual with Thermal Lockout D8 = Visual w/ thermal lockout Electrical MS5 = Electrical w/ 12 in. 18 gauge 4-conductor cable MS5LC = Low current MS5 MS10 = Electrical w/ DIN connector (male end only) MS10LC = Low current MS10 MS11 = Electrical w/ 12 ft. 4-conductor wire MS12 = Electrical w/ 5 pin Brad Harrison connector (male end only) MS12LC = Low current MS12 MS16 = Electrical w/ weather-packed sealed connector MS16LC = Low current MS16 MS17LC = Electrical w/ 4 pin Brad Harrison male connector MS5T = MS5 (see above) w/ thermal lockout MS5LCT = Low current MS5T MS10T = MS10 (see above) w/ thermal lockout MS10LCT = Low current MS10T MS12T = MS12 (see above) w/ thermal lockout MS12LCT = Low current MS12T MS16T = MS16 (see above) w/ thermal lockout MS16LCT = Low current MS16T MS17LCT = Low current MS17T Electrical Visual MS = Cam operated switch w/ 1/2" conduit female connection MS13 = Supplied w/ threaded connector & light MS14 = Supplied w/ 5 pin Brad Harrison connector & light (male end) Electrical Visual with Thermal Lockout MS13DCT = MS13 (see above), direct current, w/ thermal lockout MS13DCLCT = Low current MS13DCT MS14DCT = MS14 (see above), direct current, w/ thermal lockout MS14DCLCT = Low current MS14DCT	Omit = None L = Two 1/4" NPTF inlet and outlet female test ports N = No-Element indicator G440 = 1/2" drain on bottom of housing

NOTES:

- Box 1. WTF1 includes a Anodized Head and a Stainless Steel Bowl.
- Box 3. Replacement element part numbers are identical to contents of Boxes 3 and 4. E media elements are only available with Buna N seals.
- Box 4. For option V, all aluminum parts are anodized. H.5 seal designation includes the following: EPR seals, stainless steel wire mesh on elements, and light oil coating on housing exterior. Viton® is a registered trademark of DuPont Dow Elastomers. Skydrol® is a registered trademark of Solutia Inc.
- Box 6. B porting option supplied with metric mounting holes.

Return Line Filter

KF3



Features and Benefits

- Meets HF4 automotive standard
- Offered in pipe, SAE straight thread, flange and ISO 228 porting
- Various Dirt Alarm® options
- Available with No-Element indicator
- Available with NPTF inlet and outlet female test ports
- Available with magnet inserts
- Available with housing drain plug
- Takes the standard “K” element in K, KK or 27K lengths
- Allows consolidation of inventoried replacement elements by using K-size elements
- Also available with DirtCatcher® elements (KD & KKD)
- G** Available with quality-protected GeoSeal® Elements (GKF3)

Part of the Schroeder Industries 2030 Initiative

100 gpm
380 L/min
300 psi
20 bar

Model No. of filter in photograph is KF31K10SD5.

Flow Rating:	Up to 100 gpm (380 L/min) for 150 SUS (32 cSt) fluids
Max. Operating Pressure:	300 psi (20 bar)
Min. Yield Pressure:	1000 psi (70 bar), per NFPA T2.6.1
Rated Fatigue Pressure:	290 psi (20 bar), per NFPA T2.6.1-2005
Temp. Range:	-20°F to 225°F (-29°C to 107°C)
Bypass Setting:	Cracking: 30 psi (2 bar) Full Flow: 51 psi (4 bar)
Porting Head:	Die Cast Aluminum
Element Case:	Steel
Weight of KF3-1K:	10.5 lbs. (4.8 kg)
Weight of KF3-2K:	14.2 lbs. (6.4 kg)
Weight of KF3-3K:	18.5 lbs. (8.4 kg)
Element Change Clearance:	1.50" (40 mm) for all lengths

Filter Housing Specifications

Type Fluid	Appropriate Schroeder Media
Petroleum Based Fluids	All E media (cellulose), Z-Media® and ASP® media (synthetic)
High Water Content	All Z-Media® and ASP® Media (synthetic)
Invert Emulsions	10 and 25 µ Z-Media® (synthetic), 10 µ ASP® media (synthetic)
Water Glycols	3, 5, 10 and 25 µ Z-Media® (synthetic), 3, 5, and 10 µ ASP® Media (synthetic)
Phosphate Esters	All Z-Media® (synthetic) with H (EPR) seal designation and 3 and 10 µ E media (cellulose) with H (EPR) seal designation and all ASP® media (synthetic)
Skydrol®	3, 5, 10 and 25 µ Z-Media® (synthetic) with H.5 seal designation (EPR seals and stainless steel wire mesh in element, and light oil coating on housing exterior) and all ASP® media (synthetic)

Fluid Compatibility

Accessories For Tank-Mounted Filters

- IRF
- TF1
- KF3**
- KL3
- LF1
- MLF1
- RLD
- GRTB
- MTA
- MTB
- ZT
- AFT
- KFT
- RT
- RTI
- LRT
- ART
- BRT
- TRT
- BFT
- QT
- KTK
- LTK
- MRT
- PAF1
- MAF1
- MF2

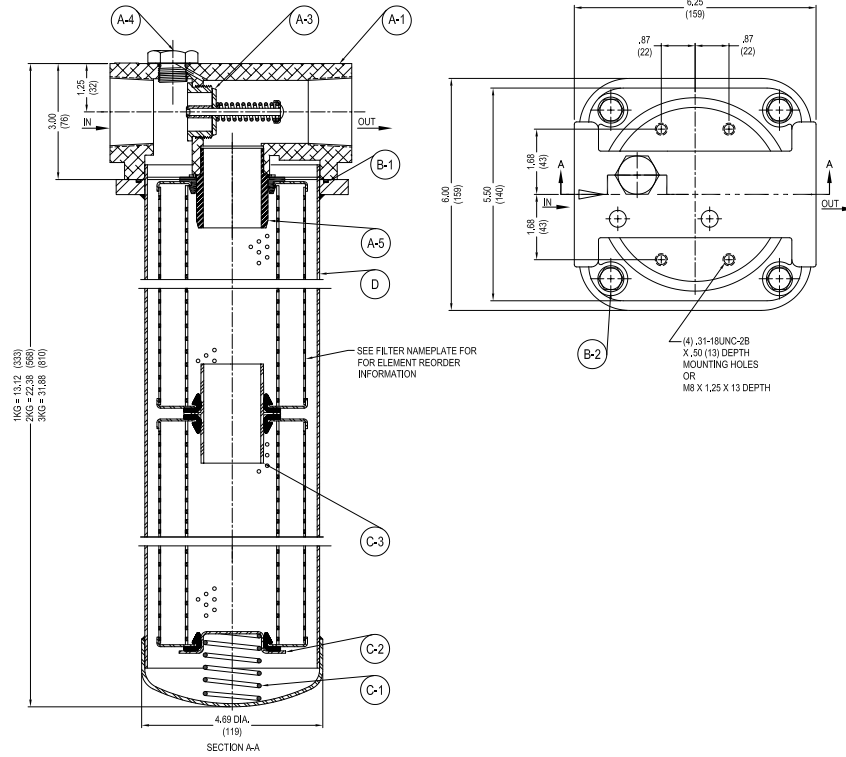

Metric dimensions in ().

Element Performance Information & Dirt Holding Capacity

Element	Filtration Ratio Per ISO 4572/NFPA T3.10.8.8 Using automated particle counter (APC) calibrated per ISO 4402			Filtration Ratio per ISO 16889 Using APC calibrated per ISO 11171	
	$\beta_x \geq 75$	$\beta_x \geq 100$	$\beta_x \geq 200$	$\beta_x(c) \geq 200$	$\beta_x(c) \geq 1000$
KZ1/KKZ1/27KZ1	<1.0	<1.0	<1.0	<4.0	4.2
KZ3/KKZ3/27KZ3	<1.0	<1.0	<2.0	<4.0	4.8
KZ5/KKZ5/27KZ5	2.5	3.0	4.0	4.8	6.3
KZ10/KKZ10/27KZ10	7.4	8.2	10.0	8.0	10.0
KZ25/KKZ25/27KZ25	18.0	20.0	22.5	19.0	24.0
KZW1	N/A	N/A	N/A	<4.0	<4.0
KZW3/KKZW3	N/A	N/A	N/A	4.0	4.8
KZW5/KKZW5	N/A	N/A	N/A	5.1	6.4
KZW10/KKZW10	N/A	N/A	N/A	6.9	8.6
KZW25/KKZW25	N/A	N/A	N/A	15.4	18.5

Element	DHC (g)	Element	DHC (g)	Element	DHC (g)	Element	DHC (g)	Element	DHC (g)	Element	DHC (g)
KZ1	112	KKZ1	224	27KZ1	336	KDZ1	89	KKDZ1	188	KZW1	61
KZ3	115	KKZ3	230	27KZ3	345	KDZ3	71	KKDZ3	150	KZW3	64
KZ5	119	KKZ5	238	27KZ5	357	KDZ5	100	KKDZ5	210	KZW5	63
KZ10	108	KKZ10	216	27KZ10	324	KDZ10	80	KKDZ10	168	KZW10	57
KZ25	93	KKZ25	186	27KZ25	279	KDZ25	81	KKDZ25	171	KZW25	79
										KKZW3	128
										KKZW5	126
										KKZW10	114
										KKZW25	158

Element Collapse Rating: 150 psid (10 bar) for standard elements

Flow Direction: Outside In

Element Nominal Dimensions: K: 3.9" (99 mm) O.D. x 9.0" (230 mm) long
 KK: 3.9" (99 mm) O.D. x 18.0" (460 mm) long
 27K: 3.9" (99 mm) O.D. x 27.0" (690 mm) long

$\Delta P_{\text{housing}}$

KF3 $\Delta P_{\text{housing}}$ for fluids with sp gr (specific gravity) = 0.86:

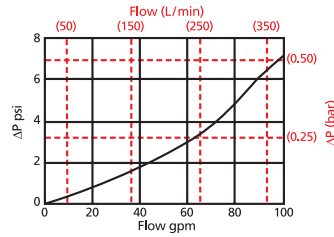

$\Delta P_{\text{element}}$

KZ

Element Pressure Drop versus Flow Rate at 32 cSt (150 SUS)

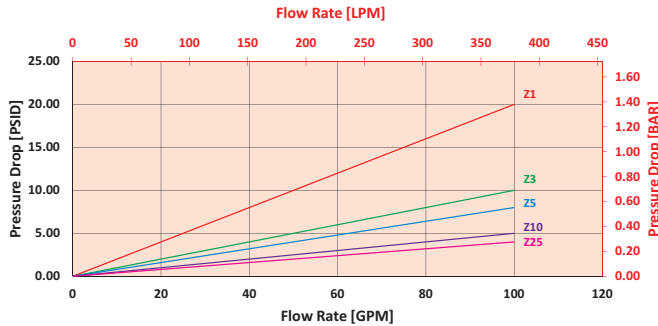

2KZ/KKZ

Element Pressure Drop versus Flow Rate at 32 cSt (150 SUS)

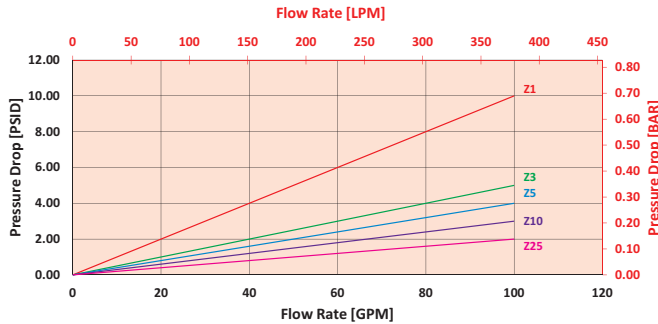

$$\Delta P_{\text{filter}} = \Delta P_{\text{housing}} + (\Delta P_{\text{element}} * V_f)$$

Exercise:

Determine ΔP_{filter} at 70 gpm (265.3 L/min) for KF31KZ10SD5 using 160 SUS (34 cSt) fluid.

Use the housing pressure curve to determine $\Delta P_{\text{housing}}$ at 70 gpm. In this case, $\Delta P_{\text{housing}}$ is 4 psi (.27 bar) on the graph for the KF3 housing.

Use the element pressure curve to determine $\Delta P_{\text{element}}$ at 70 gpm. In this case, $\Delta P_{\text{element}}$ is 3 psi (.21 bar) according to the graph for the KZ10 element.

Because the viscosity in this sample is 160 SUS (34 cSt), we determine the Viscosity Factor (V_f) by dividing the Operating Fluid Viscosity with the Standard Viscosity of 150 SUS (32 cSt). To best determine your Operating Fluid Viscosity, please reference the chart in Appendix D.

Finally, the overall filter pressure differential, ΔP_{filter} , is calculated by adding $\Delta P_{\text{housing}}$ with the true element pressure differential, ($\Delta P_{\text{element}} * V_f$). The $\Delta P_{\text{element}}$ from the graph has to be multiplied by the viscosity factor to get the true pressure differential across the element.

Solution:

$\Delta P_{\text{housing}} = 4 \text{ psi } [.227 \text{ bar}] \mid \Delta P_{\text{element}} = 3 \text{ psi } [.21 \text{ bar}]$

$V_f = 160 \text{ SUS (34 cSt)} / 150 \text{ SUS (32 cSt)} = 1.1$

$\Delta P_{\text{filter}} = 4 \text{ psi} + (3 \text{ psi} * 1.1) = 7.7 \text{ psi}$

OR

$\Delta P_{\text{filter}} = .27 \text{ bar} + (.21 \text{ bar} * 1.1) = .50 \text{ bar}$

Pressure Drop Information Based on Flow Rate and Viscosity

Note:
If your element is not graphed, use the following equation:
 $\Delta P_{\text{element}} = \text{Flow Rate} \times \Delta P_f$. Plug this variable into the overall pressure drop equation.

Ele.	ΔP	Ele.	ΔP	Ele.	ΔP
K3	0.25	2K3/ KK3	0.12	3KZ1/ 27KZ1	0.05
K10	0.09	2K10/ KK10	0.05	3KZ3/ 27KZ3	0.03
K25	0.02	2K25/ KK25	0.01	3KZ5/ 27KZ5	0.02
KAS3	0.10	2KAS3/ KKAS3	0.05	3KZ10/ 27KZ10	0.02
KAS5	0.08	2KAS5/ KKAS5	0.04	3KZ25/ 27KZ25	0.01
KAS10	0.05	2KAS10/ KKAS10	0.03	K3K	0.08
KDZ1	0.24	2KDZ1	0.12	3K10	0.03
KDZ3	0.12	2KDZ3	0.06	3K25	0.01
KDZ5	0.10	2KDZ5	0.05	3KAS3/ 27KAS3	0.03
KDZ10	0.06	2KDZ10	0.03	3KAS5/ 27KAS5	0.02
KDZ25	0.04	2KDZ25	0.02	3KAS10/ 27KAS10	0.02
KZW1	0.43	2KZW1	-		
KZW3	0.32	2KZW3/ KKZW3	0.16		
KZW5	0.28	2KZW5/ KKZW5	0.14		
KZW10	0.23	2KZW10/ KKZW10	0.12		
KZW25	0.14	2KZW25/ KKZW25	0.07		

Filter Model Number Selection

Highlighted product eligible for **QuickDelivery**

How to Build a Valid Model Number for a Schroeder KF3:

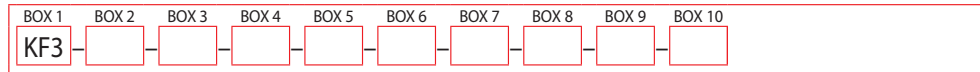

Example: NOTE: Only box 10 may contain more than one option

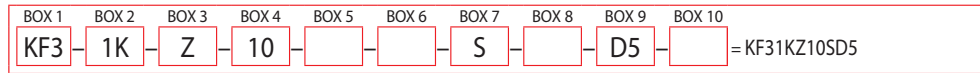

BOX 1	BOX 2	BOX 3	BOX 4	BOX 5	BOX 6	BOX 7	BOX 8	BOX 9	BOX 10
Filter Series	Number & Size of Elements	Media Type				Micron Rating			
KF3	1K, KK,27K	Omit = E media (cellulose) AS = Anti-Static Pleat Media Z = Excellement® Z-Media® (synthetic) ZW = Aqua-Excellement® ZW media W = Water Removal media M = M Media (reusable metal) DZ = DirtCatcher® Excellement® Z-Media®				1 = 1 μ (Z, ZW and DZ media) 3 = 3 μ (E, AS, Z, ZW and DZ media) 5 = 5 μ (AS, Z, ZW and DZ media) 10 = 10 μ (E, AS, Z, ZW, M and DZ media) 25 = 25 μ (E, Z, ZW, M and DZ media) 60 = 60 μ (M media)			
GKF3 (GeoSeal®)	2K 3K	Water System Element Options KM10 = K size 25 μ M media (reusable metal) KM25 = K size 10 μ M media (reusable metal) KM60 = K size 60 μ M media (reusable metal) KM150 = K size 150 μ M media (reusable metal) KM260 = K size 260 μ M media (reusable metal)							
WKF3 (Water)	GeoSeal® 1KG, KKG,27KG 2KG 3KG								
Seal Material					Magnet Option		Porting		
Omit = Buna N H = EPR V = Viton® H.5 = Skydrol® Compatibility W = Buna N with anodized parts					Omit = None M = Magnet		P = 1½" NPTF S = SAE-24 F = 1½" SAE-4-bolt flange Code 61 B = ISO 228 G-1½"		
Bypass Settings									
Omit = 30 psi cracking 40 = 40 psi bypass 50 = 50 psi cracking (req. for HF4) 60 = 60 psi bypass									

NOTES:

- Box 2. Double and triple stacking of K-size elements can be replaced by single KK and 27K elements, respectively. Number of elements must equal 1 when using KK or 27K elements. ZW media not available in 27K.
- Box 3. Replacement element part numbers are identical to contents of Boxes 2, 3, 4, and 5.
- Box 5. For options H, W, V, and H.5, all aluminum parts are anodized. H.5 seal designation includes the following: EPR seals, stainless steel wire mesh on elements, and light oil coating on housing exterior. Viton® is a registered trademark of DuPont Dow Elastomers. Skydrol® is a registered trademark of Solutia Inc.
- Box 7. For option F, bolt thread depth .63" (16 mm). B porting option supplied with metric mounting holes.
- Box 10. Option L not available with MS Dirt Alarm

Dirt Alarm® Options		Additional Options	
Omit = None		Omit = None	
Visual	D = Pointer D5 = Visual pop-up	L = Two ¼" NPTF inlet and outlet test ports N = No-Element indicator	
Visual with Thermal Lockout	D8 = Visual w/ thermal lockout	G426 = ¾" drain on bottom of housing G440 = ½" drain on bottom of housing	
Electrical	MS5 = Electrical w/ 12 in. 18 gauge 4-conductor cable MS5LC = Low current MS5 MS10 = Electrical w/ DIN connector (male end only) MS10LC = Low current MS10 MS11 = Electrical w/ 12 ft. 4-conductor wire MS12 = Electrical w/ 5 pin Brad Harrison connector (male end only) MS12LC = Low current MS12 MS16 = Electrical w/ weather-packed sealed connector MS16LC = Low current MS16		
Electrical with Thermal Lockout	MS17LC = Electrical w/ 4 pin Brad Harrison male connector MS5T = MS5 (see above) w/ thermal lockout MS5LCT = Low current MS5T MS10T = MS10 (see above) w/ thermal lockout MS10LCT = Low current MS10T MS12T = MS12 (see above) w/ thermal lockout MS12LCT = Low current MS12T MS16T = MS16 (see above) w/ thermal lockout MS16LCT = Low current MS16T MS17LCT = Low current MS17T		
Electrical Visual	MS = Cam operated switch w/ ½" conduit female connection MS13 = Supplied w/ threaded connector & light MS14 = Supplied w/ 5 pin Brad Harrison connector & light (male end)		
Electrical Visual with Thermal Lockout	MS13DCT = MS13 (see above), direct current, w/ thermal lockout MS13DCLCT = Low current MS13DCT MS14DCT = MS14 (see above), direct current, w/ thermal lockout MS14DCLCT = Low current MS14DCT		

Return Line Filter with Threaded Bowl

KL3



Features and Benefits

- Threaded bowl allows for easier removal and facilitates element changes
- Available with 18LC and K-size elements
- Available with 1½" and 2" porting
- Offered in pipe, SAE straight thread, ISO 228, and flange porting
- Various Dirt Alarm® options
- Available with NPTF inlet and outlet female test ports
- Available with housing drain plug
- G** Available with quality-protected GeoSeal® Elements (GKL3)

120 gpm
455 L/min
 300 psi
20 bar

- IRF
- TF1
- KF3
- KL3**
- LF1
- MLF1
- RLD
- GRTB
- MTA
- MTB
- ZT
- AFT
- KFT
- RT
- RTI
- LRT
- ART
- BRT
- TRT
- BFT
- QT
- KTK
- LTK
- MRT

Model No. of filter in photograph is KL31KZ10F24.

Flow Rating:	Up to 100 gpm (380 L/min) for 150 SUS (32 cSt) fluids for P24, S24, F24 and B24 porting Up to 120 gpm (455 L/min) for 150 SUS (32 cSt) fluids for P32, S32 and B32 porting
Max. Operating Pressure:	300 psi (20 bar)
Min. Yield Pressure:	1000 psi (70 bar), per NFPA T2.6.1
Rated Fatigue Pressure:	300 psi (20 bar), per NFPA T2.6.1-2005
Temp. Range:	-20°F to 225°F (-29°C to 107°C)
Bypass Setting:	Cracking: 30 psi (2 bar) Full Flow: 68 psi (4.7 bar)
Porting Head:	Cast Aluminum
Element Case:	Steel
Weight of KL3-18LC:	20.00 lbs. (9.1 kg)
Weight of KL3-1K:	14.75 lbs. (6.7 kg)
Weight of KL3-2K:	18.50 lbs. (8.4 kg)
Weight of KL3-3K:	22.75 lbs. (10.3 kg)
Element Change Clearance:	2.50" (64 mm)

Filter Housing Specifications

Type Fluid	Appropriate Schroeder Media
Petroleum Based Fluids	All E media (cellulose), Z-Media® and ASP® media (synthetic)
High Water Content	All Z-Media® and ASP® media (synthetic)
Invert Emulsions	10 and 25 µ Z-Media® (synthetic), 10 µ ASP® media (synthetic)
Water Glycols	3, 5, 10 and 25 µ Z-Media® (synthetic), 3, 5, and 10 µ ASP® media (synthetic)
Phosphate Esters	All Z-Media® with H (EPR) seal designation and all ASP® media (synthetic)

Fluid Compatibility

Accessories For Tank-Mounted Filters

- PAF1
- MAF1
- MF2

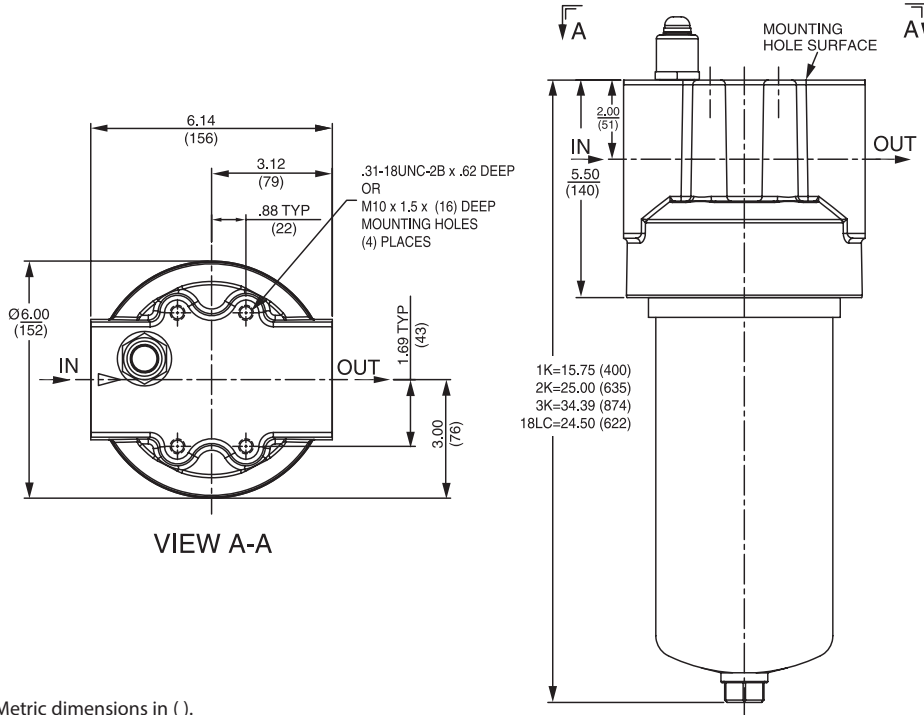

Metric dimensions in ().

Element Performance Information & Dirt Holding Capacity

Element	Filtration Ratio Per ISO 4572/NFPAT3.10.8.8 Using automated particle counter (APC) calibrated per ISO 4402			Filtration Ratio per ISO 16889 Using APC calibrated per ISO 11171	
	$\beta_x \geq 75$	$\beta_x \geq 100$	$\beta_x \geq 200$	$\beta_x(c) \geq 200$	$\beta_x(c) \geq 1000$
KZ1/KKZ1/27KZ1	<1.0	<1.0	<1.0	<4.0	4.2
KZ3/KKZ3/27KZ3	<1.0	<1.0	<2.0	<4.0	4.8
KZ5/KKZ5/27KZ5	2.5	3.0	4.0	4.8	6.3
KZ10/KKZ10/27KZ10	7.4	8.2	10.0	8.0	10.0
KZ25/KKZ25/27KZ25	18.0	20.0	22.5	19.0	24.0
KZW1	N/A	N/A	N/A	<4.0	<4.0
KZW3/KKZW3	N/A	N/A	N/A	4.0	4.8
KZW5/KKZW5	N/A	N/A	N/A	5.1	6.4
KZW10/KKZW10	N/A	N/A	N/A	6.9	8.6
KZW25/KKZW25	N/A	N/A	N/A	15.4	18.5
18LCZ1	<1.0	<1.0	<1.0	<4.0	4.2
18LCZ3	<1.0	<1.0	<2.0	<4.0	4.8
18LCZ5	2.5	3.0	4.0	4.8	6.3
18LCZ10	7.4	8.2	10.0	8.0	10.0
18LCZ25	18.0	20.0	22.5	19.0	24.0

Element	DHC (g)	Element	DHC (g)	Element	DHC (g)	Element	DHC (g)	Element	DHC (g)	Element	DHC (g)
KZ1	112	KKZ1	224	27KZ1	336	KZW1	61	18LCZ1	224		
KZ3	115	KKZ3	230	27KZ3	345	KZW3	64	KKZW3	128	18LCZ3	230
KZ5	119	KKZ5	238	27KZ5	357	KZW5	63	KKZW5	126	18LCZ5	238
KZ10	108	KKZ10	216	27KZ10	324	KZW10	57	KKZW10	114	18LCZ10	216
KZ25	93	KKZ25	186	27KZ25	279	KZW25	79	KKZW25	158	18LCZ25	186

Element Collapse Rating: 150 psid (10 bar) for standard elements
 Flow Direction: Outside In
 Element Nominal Dimensions: K: 3.9" (99 mm) O.D. x 9.0" (230 mm) long
 KK: 3.9" (99 mm) O.D. x 18.0" (460 mm) long
 27K: 3.9" (99 mm) O.D. x 27.0" (690 mm) long
 18LC: 4.0" (100 mm) O.D. x 18.5" (470 mm) long

Return Line Filter with Threaded Bowl

KL3

$\Delta P_{\text{housing}}$

KL3 $\Delta P_{\text{housing}}$ for fluids with sp gr (specific gravity) = 0.86:

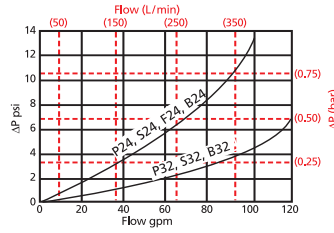

$\Delta P_{\text{element}}$

KZ

Element Pressure Drop versus Flow Rate at 32 cSt (150 SUS)

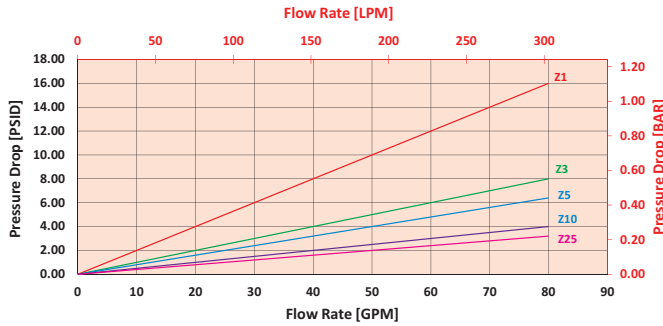

2KZ/KKZ

Element Pressure Drop versus Flow Rate at 32 cSt (150 SUS)

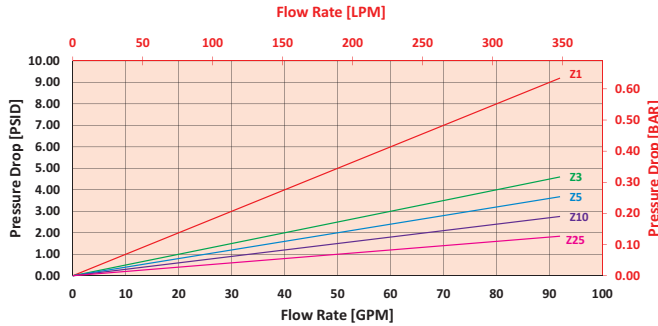

$$\Delta P_{\text{filter}} = \Delta P_{\text{housing}} + (\Delta P_{\text{element}} * V_f)$$

Exercise:

Determine ΔP_{filter} at 70 gpm (265.3 L/min) for KL31KZ10P24D5L using 160 SUS (34 cSt) fluid.

Use the housing pressure curve to determine $\Delta P_{\text{housing}}$ at 70 gpm. In this case, $\Delta P_{\text{housing}}$ is 7 psi (.48 bar) on the graph for the KL3 housing.

Use the element pressure curve to determine $\Delta P_{\text{element}}$ at 70 gpm. In this case, $\Delta P_{\text{element}}$ is 3 psi (.21 bar) according to the graph for the KZ10 element.

Because the viscosity in this sample is 160 SUS (34 cSt), we determine the Viscosity Factor (V_f) by dividing the Operating Fluid Viscosity with the Standard Viscosity of 150 SUS (32 cSt). To best determine your Operating Fluid Viscosity, please reference the chart in Appendix D.

Finally, the overall filter pressure differential, ΔP_{filter} , is calculated by adding $\Delta P_{\text{housing}}$ with the true element pressure differential, ($\Delta P_{\text{element}} * V_f$). The $\Delta P_{\text{element}}$ from the graph has to be multiplied by the viscosity factor to get the true pressure differential across the element.

Solution:

$\Delta P_{\text{housing}} = 7 \text{ psi } [.48 \text{ bar}] \mid \Delta P_{\text{element}} = 3 \text{ psi } [.21 \text{ bar}]$

$V_f = 160 \text{ SUS (34 cSt)} / 150 \text{ SUS (32 cSt)} = 1.1$

$\Delta P_{\text{filter}} = 7 \text{ psi} + (3 \text{ psi} * 1.1) = 10.7 \text{ psi}$

OR

$\Delta P_{\text{filter}} = .48 \text{ bar} + (.21 \text{ bar} * 1.1) = .71 \text{ bar}$

Pressure Drop Information Based on Flow Rate and Viscosity

Note:

If your element is not graphed, use the following equation:
 $\Delta P_{\text{element}} = \text{Flow Rate} \times \Delta P_f$. Plug this variable into the overall pressure drop equation.

Ele.	ΔP	Ele.	ΔP	Ele.	ΔP
K3	0.25	2K3/KK3	0.12	18LC3	0.12
K10	0.09	2K10/KK10	0.05	18L10	0.05
K25	0.02	2K25/KK25	0.01	18LCZ1	0.10
KAS3	0.10	2KAS3/KKAS3	0.05	18LCZ3	0.05
KAS5	0.08	2KAS5/KKAS5	0.04	18LCZ5	0.04
KAS10	0.05	2KAS10/KKAS10	0.03	18LCZ10	0.03
KZW1	0.43	2KZW1	-	18LCZ25	0.02
KZW3	0.32	2KZW3/KKZW3	0.16		
KZW5	0.28	2KZW5/KKZW5	0.14		
KZW10	0.23	2KZW10/KKZW10	0.12		
KZW25	0.14	2KZW25/KKZW25	0.07		

Filter Model Number Selection

How to Build a Valid Model Number for a Schroeder KL3:

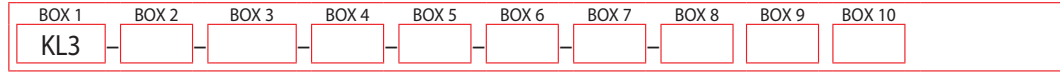

Example: Option 1 NOTE: One option per box

Option 2 NOTE: One option per box

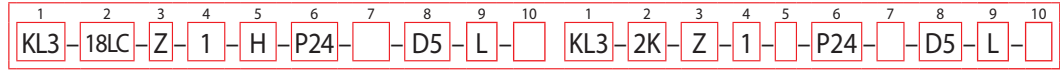

BOX 1 Filter Series	BOX 2 Option 1 Size	BOX 3 Option 1 Media Type	BOX 4 Option 1 Micron Rating
KL3 GKL3 (GeoSeal®) WKL3 (Water)	18LC	Omit = E media (cellulose) Z = Excellement® Z-Media® (synthetic) Water System Element Option KM10 = 10 µM media (reusable metal) KM25 = 25 µM media (reusable metal) KM60 = 60 µM media (reusable metal) KM150 = 150 µM media (reusable metal) KM260 = 260 µM media (reusable metal)	1 = 1 µ (Z-Media®) 3 = 3 µ (E and Z-Media®) 5 = 5 µ (Z-Media®) 10 = 10 µ (E and Z-Media®) 25 = 25 µ (E and Z-Media®)

BOX 2 Option 2 Number & Size of Elements	BOX 3 Option 2 Media Type	BOX 4 Option 2 Micron Rating	BOX 5 Seal Material
1K, KK, 27K 2K 3K	Omit = E media (cellulose) Z = Excellement® Z-Media® (synthetic) AS = Anti-Static Pleat Media (synthetic) ZW = Aqua-Excellement® ZW media W = Water Removal media M = M media (reusable metal) DZ = DirtCatcher® Excellement® Z-Media®	1 = 1 µ (Z, ZW and DZ media) 3 = 3 µ (E, AS, Z, ZW and DZ media) 5 = 5 µ (AS, Z, ZW and DZ media) 10 = 10 µ (E, AS, Z, ZW, M and DZ media) 25 = 25 µ (E, Z, ZW, M and DZ media) 60 = 60 µ (M media)	Omit = Buna N H = EPR V = Viton® H.5 = Skydrol® Compatibility W = Buna N

BOX 6 Porting	BOX 7 Bypass Setting
P24 = 1½" NPTF S24 = SAE-24 F24 = 1½" SAE 4-bolt flange Code 61 B24 = ISO 228 G-1½" P32 = 2" NPTF S32 = SAE-32 B32 = SO 228 G-2"	Omit = 30 psi cracking 40 = 40 PSI Bypass 50 = 50 psi cracking (req. for HF4)

BOX 8 Dirt Alarm® Options		BOX 9 Test Port Options	BOX 10 Bowl Drain Option
Omit = None		Omit = None L = Two ¼" NPTF inlet and outlet female test ports	Omit = None DR = ¾" drain on bottom of housing
Visual	D5 = Visual pop-up		
Visual with Thermal Lockout	D8 = Visual w/ thermal lockout		
Electrical	MS5 = Electrical w/ 12 in. 18 gauge 4-conductor cable		
	MS5LC = Low current MS5		
	MS10 = Electrical w/ DIN connector (male end only)		
	MS10LC = Low current MS10		
	MS11 = Electrical w/ 12 ft. 4-conductor wire		
	MS12 = Electrical w/ 5 pin Brad Harrison connector (male end only)		
Electrical with Thermal Lockout	MS12LC = Low current MS12		
	MS16 = Electrical w/ weather-packed sealed connector		
	MS16LC = Low current MS16		
	MS17LC = Electrical w/ 4 pin Brad Harrison male connector		
	MS5T = MS5 (see above) w/ thermal lockout		
	MS5LCT = Low current MS5T		
Electrical Visual	MS10T = MS10 (see above) w/ thermal lockout		
	MS10LCT = Low current MS10T		
	MS12T = MS12 (see above) w/ thermal lockout		
	MS12LCT = Low current MS12T		
	MS16T = MS16 (see above) w/ thermal lockout		
	MS16LCT = Low current MS16T		
Electrical Visual with Thermal Lockout	MS17LCT = Low current MS17T		
	MS13 = Supplied w/ threaded connector & light		
	MS14 = Supplied w/ 5 pin Brad Harrison connector & light (male end)		
	MS13DCT = MS13 (see above), direct current, w/ thermal lockout		
	MS13DCLCT = Low current MS13DCT		
	MS14DCT = MS14 (see above), direct current, w/ thermal lockout		
	MS14DCLCT = Low current MS14DCT		

NOTES:

Box 2. Double and triple stacking of K-size elements can be replaced by single KK and 27K elements, respectively. Number of elements must equal 1 when using KK or 27K elements. Replacement element part numbers are identical to contents of Boxes 2, 3, 4, and 5. ZW media not available in 27K length. Example: 18LCZ3V

Box 5. For options H, W, V, and H.5, all aluminum parts are anodized. H.5 seal designation includes the following: EPR seals, stainless steel wire mesh on elements, and light oil coating on housing exterior. Viton® is a registered trademark of DuPont Dow Elastomers. Skydrol® is a registered trademark of Solutia Inc.

Box 6. B24 and B32 porting options supplied with metric mounting holes. 18LC elements require 2" ports for up to 120 gpm. K size elements require 1½" ports for up to 100 gpm.

Return Line Filter with 2" Ports

LF1



Features and Benefits

- Offered in pipe, SAE straight thread and ISO 228 porting
- Available in 18" element lengths only
- Various Dirt Alarm® options
- Available with NPTF inlet and outlet female test ports
- Available with 2" porting with "K" size element
- Available with housing drain plug

120 gpm
455 L/min
 300 psi
 20 bar

IRF
 TF1
 KF3
 KL3
LF1

MLF1
 RLD
 GRTB
 MTA
 MTB
 ZT
 AFT
 KFT
 RT

Model No. of filter in photograph is LF118LCZ10P32D.

Flow Rating:	Up to 120 gpm (455 L/min) for 150 SUS (32 cSt) fluids
Max. Operating Pressure:	300 psi (20 bar)
Min. Yield Pressure:	1000 psi (70 bar), per NFPA T2.6.1
Rated Fatigue Pressure:	250 psi (17 bar), per NFPA T2.6.1-2005
Temp. Range:	-20°F to 225°F (-29°C to 107°C)
Bypass Setting:	Cracking: 30 psi (2.1 bar) Full Flow: 60 psi (4.1 bar)
Porting Head:	Cast Aluminum
Element Case:	Steel
Available Porting:	2" NPTF, 2½"-12 SAE Straight
Weight of LF1-18LC:	17.5 lbs. (7.9 kg)
Element Change Clearance:	2.0" (55 mm)

Filter Housing Specifications

Type Fluid	Appropriate Schroeder Media
Petroleum Based Fluids	All E media (cellulose) and Z-Media® (synthetic)
High Water Content	All Z-Media (synthetic)
Invert Emulsions	10 and 25 µ Z-Media® (synthetic)
Water Glycols	3, 5, 10 and 25 µ Z-Media® (synthetic)
Phosphate Esters	All Z-Media® (synthetic) with H (EPR) seal designation
Skydrol®	3, 5, 10 and 25 µ Z-Media® (synthetic) with H.5 seal designation (EPR seals and stainless steel wire mesh in element, and light oil coating on housing exterior)

Fluid Compatibility

Accessories For Tank-Mounted Filters

PAF1
 MAF1
 MF2

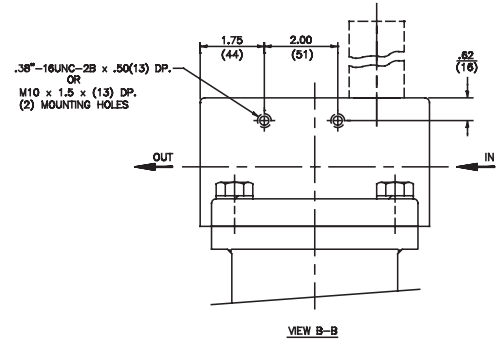
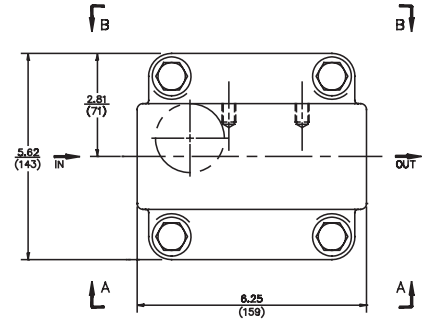
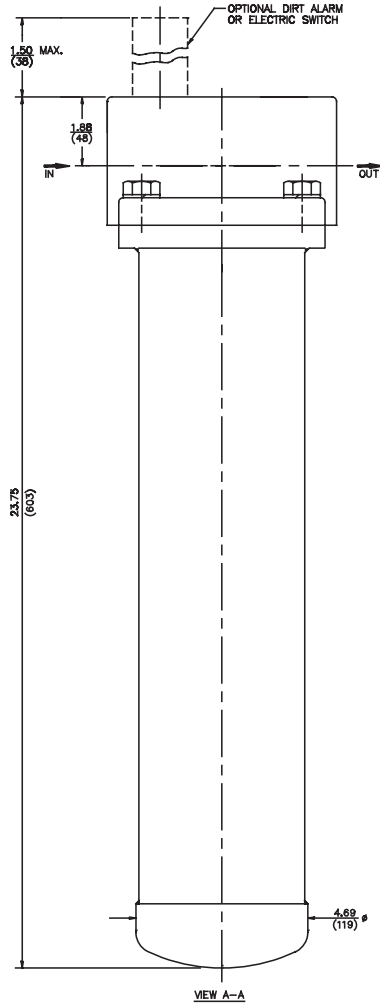

Metric dimensions in ().

Element Performance Information & Dirt Holding Capacity

Element	Filtration Ratio Per ISO 4572/NFPA T3.10.8.8 Using automated particle counter (APC) calibrated per ISO 4402			Filtration Ratio per ISO 16889 Using APC calibrated per ISO 11171	
	$\beta_x \geq 75$	$\beta_x \geq 100$	$\beta_x \geq 200$	$\beta_{x(c)} \geq 200$	$\beta_{x(c)} \geq 1000$
18LCZ1	<1.0	<1.0	<1.0	<4.0	4.2
18LCZ3	<1.0	<1.0	<2.0	<4.0	4.8
18LCZ5	2.5	3.0	4.0	4.8	6.3
18LCZ10	7.4	8.2	10.0	8.0	10.0
18LCZ25	18.0	20.0	22.5	19.0	24.0

Element	DHC (gm)
18LCZ1	224
18LCZ3	230
18LCZ5	238
18LCZ10	216
18LCZ25	186

Element Collapse Rating: 150 psid (10 bar)

Flow Direction: Outside In

Element Nominal Dimensions: 4.0" (100 mm) O.D. x 18.5" (470 mm) long

$\Delta P_{\text{housing}}$

LF1-2" $\Delta P_{\text{housing}}$ for fluids with sp gr (specific gravity) = 0.86:

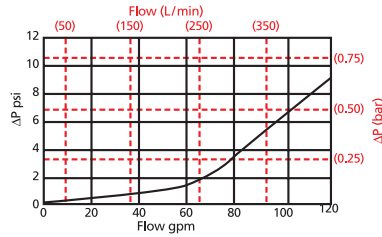

$\Delta P_{\text{element}}$

18LCZ

Element Pressure Drop versus Flow Rate at 32 cSt (150 SUS)

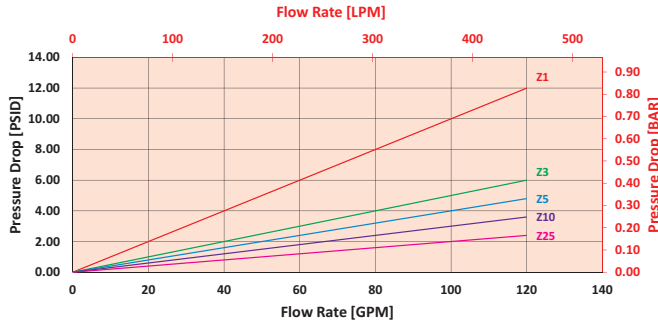

$$\Delta P_{\text{filter}} = \Delta P_{\text{housing}} + (\Delta P_{\text{element}} * V_f)$$

Exercise:

Determine ΔP_{filter} at 70 gpm (265.3 L/min) for LF118LCZ3P32D5 using 160 SUS (34 cSt) fluid.

Use the housing pressure curve to determine $\Delta P_{\text{housing}}$ at 70 gpm. In this case, $\Delta P_{\text{housing}}$ is 2 psi (.14 bar) on the graph for the LF1 housing.

Use the element pressure curve to determine $\Delta P_{\text{element}}$ at 70 gpm. In this case, $\Delta P_{\text{element}}$ is 3.5 psi (.24 bar) according to the graph for the 18LCZ3 element.

Because the viscosity in this sample is 160 SUS (34 cSt), we determine the Viscosity Factor (V_f) by dividing the Operating Fluid Viscosity with the Standard Viscosity of 150 SUS (32 cSt). To best determine your Operating Fluid Viscosity, please reference the chart in Appendix D.

Finally, the overall filter pressure differential, ΔP_{filter} , is calculated by adding $\Delta P_{\text{housing}}$ with the true element pressure differential, ($\Delta P_{\text{element}} * V_f$). The $\Delta P_{\text{element}}$ from the graph has to be multiplied by the viscosity factor to get the true pressure differential across the element.

Solution:

$$\Delta P_{\text{housing}} = 2 \text{ psi } [.14 \text{ bar}] \quad | \quad \Delta P_{\text{element}} = 3.5 \text{ psi } [.24 \text{ bar}]$$

$$V_f = 160 \text{ SUS } (34 \text{ cSt}) / 150 \text{ SUS } (32 \text{ cSt}) = 1.1$$

$$\Delta P_{\text{filter}} = 2 \text{ psi } + (3.5 \text{ psi } * 1.1) = 5.9 \text{ psi}$$

OR

$$\Delta P_{\text{filter}} = .14 \text{ bar } + (.24 \text{ bar } * 1.1) = .40 \text{ bar}$$

Filter Model Number Selection

How to Build a Valid Model Number for a Schroeder LF1:

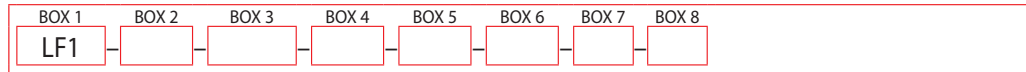

Example: NOTE: Only box 8 may contain more than one option

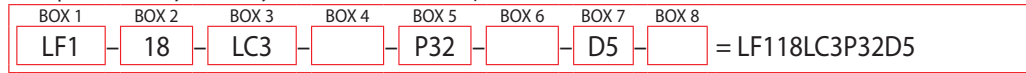

BOX 1	BOX 2	BOX 3	BOX 4
Filter Series	Length of Element (in)	Element Size and Media	
LF1	18	LC3 = LC size 3 μE media (cellulose) LC10 = LC size 10 μE media (cellulose) LCZ1 = LC size 1 μExcellement® Z-Media™ (synthetic) LCZ3 = LC size 3 μExcellement Z-Media (synthetic) LCZ5 = LC size 5 μExcellement Z-Media (synthetic) LCZ10 = LC size 10 μExcellement Z-Media (synthetic) LCZ25 = LC size 25 μExcellement Z-Media (synthetic)	
WLF1 (Water)		Seal Material	
		Omit = Buna N H = EPR V = Viton® H.5 = Skydrol® Compatibility	

BOX 5	BOX 7	BOX 8
Porting	Dirt Alarm® Options	Additional Options
P32 = 2" NPTF S32 = SAE-32 B32 = ISO 228 G-2"	Omit = None D = Pointer Visual D5 = Visual pop-up Visual with Thermal Lockout D8 = Visual w/ thermal lockout	Omit = None L = Two ¼" NPTF inlet and outlet female test ports G426 = ¾" drain on bottom of housing G440 = ½" drain on bottom of housing
Bypass	Electrical	
Omit = 30 PSI Bypass 50 = 50 PSI Bypass	MS5 = Electrical w/ 12 in. 18 gauge 4-conductor cable MS5LC = Low current MS5 MS10 = Electrical w/ DIN connector (male end only) MS10LC = Low current MS10 MS11 = Electrical w/ 12 ft. 4-conductor wire MS12 = Electrical w/ 5 pin Brad Harrison connector (male end only) MS12LC = Low current MS12 MS16 = Electrical w/ weather-packed sealed connector MS16LC = Low current MS16 MS17LC = Electrical w/ 4 pin Brad Harrison male connector	
	Electrical with Thermal Lockout	
	MS5T = MS5 (see above) w/ thermal lockout MS5LCT = Low current MS5T MS10T = MS10 (see above) w/ thermal lockout MS10LCT = Low current MS10T MS12T = MS12 (see above) w/ thermal lockout MS12LCT = Low current MS12T MS16T = MS16 (see above) w/ thermal lockout MS16LCT = Low current MS16T MS17LCT = Low current MS17T	
	Electrical Visual	
	MS = Cam operated switch w/ ½" conduit female connection MS13 = Supplied w/ threaded connector & light MS14 = Supplied w/ 5 pin Brad Harrison connector & light (male end)	
	Electrical Visual with Thermal Lockout	
	MS13DCT = MS13 (see above), direct current, w/ thermal lockout MS13DCLCT = Low current MS13DCT MS14DCT = MS14 (see above), direct current, w/ thermal lockout MS14DCLCT = Low current MS14DCT	

NOTES:

- Box 2. Replacement element part numbers are a combination of Boxes 2, 3, and 4. Example: 18LCZ3V
- Box 4. For options H, V, and H.5, all aluminum parts are anodized. H.5 seal designation includes the following: EPR seals, stainless steel wire mesh on elements, and light oil coating on housing exterior. Viton® is a registered trademark of DuPont Dow Elastomers. Skydrol® is a registered trademark of Solutia Inc.
- Box 5. B porting option supplied with metric mounting holes.

Top-Ported Return Line Filter

MLF1



Features and wBenefits

- Equipped with inlet and outlet manifolds
- Meets HF4 automotive standard
- Offered in pipe and flange porting
- Available in 2, 4 or 6 element configurations
- Various Dirt Alarm® options
- Available with NPTF inlet and outlet female test ports
- Available with housing drain plugs
- **G** Available with quality-protected GeoSeal® Elements (GMLF1)

200 gpm
760 L/min
 300 psi
20 bar

Model No. of filter in photograph is MLF14K10PD.

Flow Rating:	Up to 200 gpm (760 L/min) for 150 SUS (32 cSt) fluids
Max. Operating Pressure:	300 psi (20 bar)
Min. Yield Pressure:	1000 psi (70 bar), per NFPA T2.6.1
Rated Fatigue Pressure:	250 psi (17 bar), per NFPA T2.6.1-2005
Temp. Range:	-20°F to 225°F (-29°C to 107°C)
Bypass Setting:	Cracking: 25 psi (2 bar) Full Flow: 60 psi (4 bar)
Porting Head:	Anodized Cast Aluminum
Element Case:	Steel
Weight of MLF1-2K:	44.0 lbs. (20.0 kg)
Weight of MLF1-4K:	50.0 lbs. (23.0 kg)
Weight of MLF1-6K:	58.0 lbs. (26.0 kg)
Element Change Clearance:	2.0" (55 mm)

Filter Housing Specifications

Type Fluid	Appropriate Schroeder Media
Petroleum Based Fluids	All E media (cellulose), Z-Media® and ASP® media (synthetic)
High Water Content	All Z-Media® (synthetic)
Invert Emulsions	10 and 25 µ Z-Media® (synthetic)
Water Glycols	3, 5, 10 and 25 µ Z-Media® (synthetic)
Phosphate Esters	All Z-Media® (synthetic) with H (EPR) seal designation and 3 and 10 µ E media (cellulose) with H (EPR) seal designation and all ASP® media (synthetic)
Skydrol®	3, 5, 10 and 25 µ Z-Media® (synthetic) with H.5 seal designation (EPR seals and stainless steel wire mesh in element, and light oil coating on housing exterior) and all ASP® media (synthetic).

Fluid Compatibility

- IRF
- TF1
- KF3
- KL3
- LF1
- MLF1**
- RLD
- GRTB
- MTA
- MTB
- ZT
- AFT
- KFT
- RT
- RTI
- LRT
- ART
- BRT
- TRT
- BFT
- QT
- KTK
- LTK
- MRT
- Accessories For Tank-Mounted Filters
- PAF1
- MAF1
- MF2

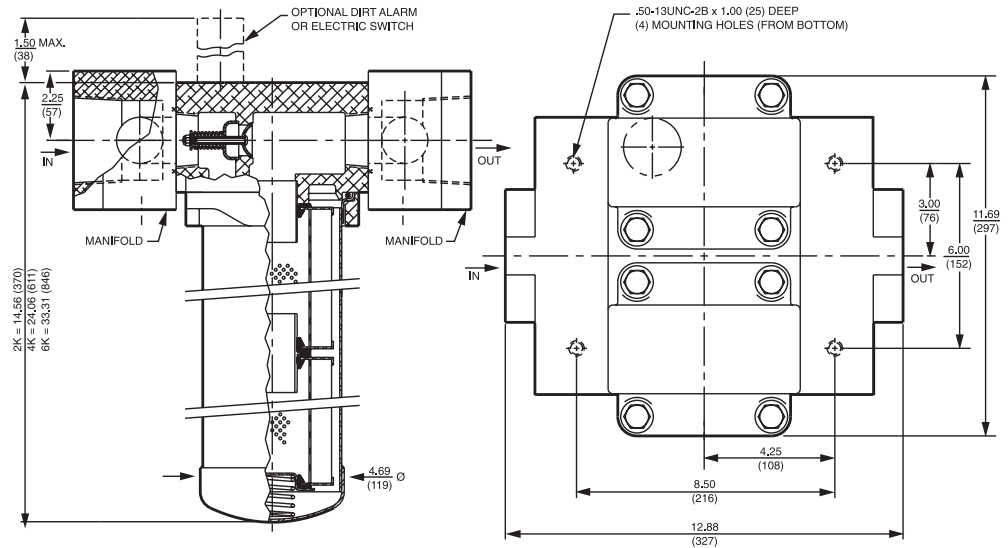

Metric dimensions in ().

Element Performance Information & Dirt Holding Capacity

Element	Filtration Ratio Per ISO 4572/NFPA T3.10.8.8 Using automated particle counter (APC) calibrated per ISO 4402			Filtration Ratio per ISO 16889 Using APC calibrated per ISO 11171	
	$\beta_x \geq 75$	$\beta_x \geq 100$	$\beta_x \geq 200$	$\beta_x(c) \geq 200$	$\beta_x(c) \geq 1000$
KZ1	<1.0	<1.0	<1.0	<4.0	4.2
KZ3	<1.0	<1.0	<2.0	<4.0	4.8
KZ5	2.5	3.0	4.0	4.8	6.3
KZ10	7.4	8.2	10.0	8.0	10.0
KZ25	18.0	20.0	22.5	19.0	24.0
KZW3	N/A	N/A	N/A	<4.0	4.8
KZW5	N/A	N/A	N/A	5.1	6.4
KZW10	N/A	N/A	N/A	6.9	8.6
KZW25	N/A	N/A	N/A	15.4	18.5

Element	DHC (gm)	Element	DHC (gm)	Element	DHC (gm)	Element	DHC (gm)
2KZ1	224	4KZ1	448	6KZ1	672	KZW3	64
2KZ3	230	4KZ3	460	6KZ3	690	KZW5	63
2KZ5	238	4KZ5	476	6KZ5	714	KZW10	67
2KZ10	216	4KZ10	432	6KZ10	648	KZW25	79
2KZ25	186	4KZ25	372	6KZ25	558		

Element Collapse Rating: 150 psid (10 bar) for standard elements

Flow Direction: Outside In

Element Nominal Dimensions: K: 3.9" (99 mm) O.D. x 9.0" (230 mm) long
 KK: 3.9" (99 mm) O.D. x 18.0" (460 mm) long
 27K: 3.9" (99 mm) O.D. x 27.0" (690 mm) long

Top-Ported Return Line Filter

MLF1

$\Delta P_{\text{housing}}$

MLF1 $\Delta P_{\text{housing}}$ for fluids with sp gr (specific gravity) = 0.86:

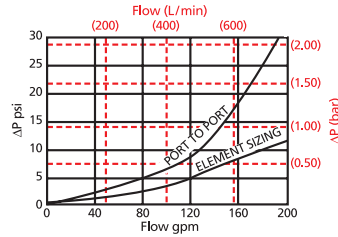

$\Delta P_{\text{element}}$

4KZ/2KKZ Element Pressure Drop versus Flow Rate at 32 cSt (150 SUS)

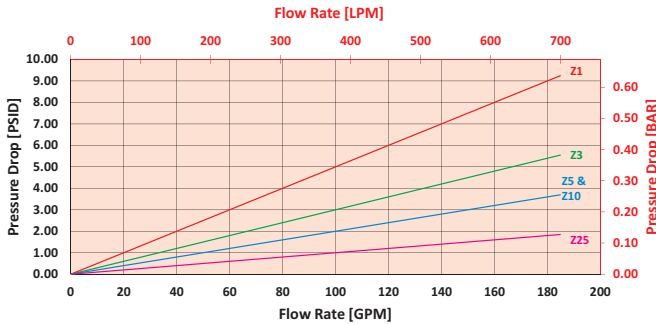

6KZ/2-27KZ Element Pressure Drop versus Flow Rate at 32 cSt (150 SUS)

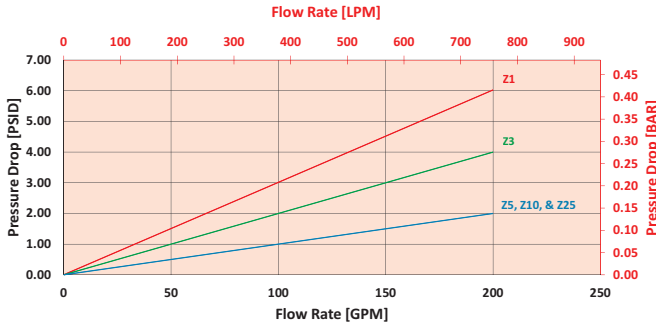

$$\Delta P_{\text{filter}} = \Delta P_{\text{housing}} + (\Delta P_{\text{element}} * V_f)$$

Exercise:

Determine ΔP_{filter} at 150 gpm (568.5 L/min) for MLF14K10PD using 160 SUS (34 cSt) fluid.

Use the housing pressure curve to determine $\Delta P_{\text{housing}}$ at 150 gpm. In this case, $\Delta P_{\text{housing}}$ is 15 psi (1 bar) on the graph for the MLF1 housing.

Use the element pressure curve to determine $\Delta P_{\text{element}}$ at 150 gpm. In this case, $\Delta P_{\text{element}}$ is 3 psi (.21 bar) according to the graph for the KKZ10 element.

Because the viscosity in this sample is 160 SUS (34 cSt), we determine the Viscosity Factor (V_f) by dividing the Operating Fluid Viscosity with the Standard Viscosity of 150 SUS (32 cSt). To best determine your Operating Fluid Viscosity, please reference the chart in Appendix D.

Finally, the overall filter pressure differential, ΔP_{filter} , is calculated by adding $\Delta P_{\text{housing}}$ with the true element pressure differential, $(\Delta P_{\text{element}} * V_f)$. The $\Delta P_{\text{element}}$ from the graph has to be multiplied by the viscosity factor to get the true pressure differential across the element.

Solution:

$\Delta P_{\text{housing}} = 15 \text{ psi [1 bar]} \mid \Delta P_{\text{element}} = 3 \text{ psi [.21 bar]}$

$V_f = 160 \text{ SUS (34 cSt)} / 150 \text{ SUS (32 cSt)} = 1.1$

$\Delta P_{\text{filter}} = 15 \text{ psi} + (3 \text{ psi} * 1.1) = 18.3 \text{ psi}$

OR

$\Delta P_{\text{filter}} = 1 \text{ bar} + (.21 \text{ bar} * 1.1) = 1.2 \text{ bar}$

Pressure Drop Information Based on Flow Rate and Viscosity

Note:

If your element is not graphed, use the following equation:

$\Delta P_{\text{element}} = \text{Flow Rate} \times \Delta P_f$. Plug this variable into the overall pressure drop equation.

Ele.	ΔP	Ele.	ΔP	Ele.	ΔP
2KZ1	0.10	2K3	0.12	4K3/ KK3	0.06
2KZ3	0.05	2K10	0.05	4K10/ KK10	0.02
2KZ5	0.04	2K25	0.01	4K25/ KK25	0.01
2KZ10	0.03	2KAS3	0.05	4KAS3/ KKAS3	0.03
2KZ25	0.02	2KAS5	0.04	4KAS5/ KKAS5	0.02
KZW3	0.32	2KAS10	0.03	4KAS10/ KKAS10	0.02
KZW5	0.28	2KZW3/ KKZW3	0.16	6KAS3/ 27KAS3	0.02
KZW10	0.23	2KZW5/ KKZW5	0.14	6KAS5/ 27KAS5	0.01
KZW25	0.14			6KAS10/ 27KAS10	0.01

Filter Model Number Selection

How to Build a Valid Model Number for a Schroeder MLF1:

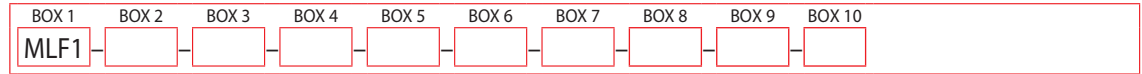

Example: NOTE: Only box 10 may contain more than one option

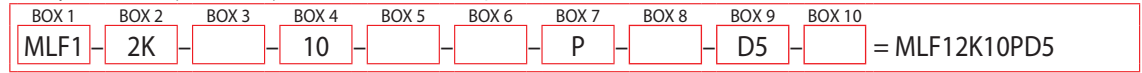

BOX 1	BOX 2	BOX 3	BOX 4
Filter Series	Number & Size of Elements	Media Type	Micron Rating
MLF1	2K, KK, 27K 4K 6K GeoSeal® 2KG, KKG, 27KG 4KG 6KG	Omit = E media (cellulose) Z = Excellement® Z-Media® (synthetic) AS = Anti-Static Pleat Media (synthetic) ZW = Aqua-Excellement™ ZW media DZ = DirtCatcher® with Excellement® Z-Media® W = W media (water removal) M = M media (reusable metal mesh)	1 = 1 μ Z, ZW, and DZ media 3 = 3 μ AS, E, Z, ZW, and DZ media 5 = 5 μ AS, Z, ZW, DZ media 10 = 10 μ AS, E, M, Z, ZW, & DZ media 25 = 25 μ E, M, Z, ZW and DZ media 60 = 60 μ M media 150 = 150 μ M media

BOX 5	BOX 6	BOX 7	BOX 8
Seal Material	Magnet Option	Porting	Bypass
Omit = Buna N H = EPR V = Viton® H.5 = Skydrol® Compatibility	Omit = None M = Magnet inserts	P = 2½" NPTF F = 2½" SAE 4-bolt flange Code 61	Omit = 25 PSI Bypass 50 = 50 PSI Bypass

BOX 9	BOX 10
Dirt Alarm® Options	Additional Options
Omit = None	Omit = None
Visual D = Pointer D5 = Visual pop-up	L = Two ¼" NPTF inlet and outlet female test ports G426 = ¾" drain on bottom of housing G440 = ½" drain on bottom of housing
Visual with Thermal Lockout D8 = Visual w/ thermal lockout	
Electrical MS5 = Electrical w/ 12 in. 18 gauge 4-conductor cable MS5LC = Low current MS5 MS10 = Electrical w/ DIN connector (male end only) MS10LC = Low current MS10 MS11 = Electrical w/ 12 ft. 4-conductor wire MS12 = Electrical w/ 5 pin Brad Harrison connector (male end only) MS12LC = Low current MS12 MS16 = Electrical w/ weather-packed sealed connector MS16LC = Low current MS16 MS17LC = Electrical w/ 4 pin Brad Harrison male connector	
Electrical with Thermal Lockout MS5T = MS5 (see above) w/ thermal lockout MS5LCT = Low current MS5T MS10T = MS10 (see above) w/ thermal lockout MS10LCT = Low current MS10T MS12T = MS12 (see above) w/ thermal lockout MS12LCT = Low current MS12T MS16T = MS16 (see above) w/ thermal lockout MS16LCT = Low current MS16T MS17LCT = Low current MS17T	
Electrical Visual MS = Cam operated switch w/ ½" conduit female connection MS13 = Supplied w/ threaded connector & light MS14 = Supplied w/ 5 pin Brad Harrison connector & light (male end)	
Electrical Visual with Thermal Lockout MS13DCT = MS13 (see above), direct current, w/ thermal lockout MS13DCLCT = Low current MS13DCT MS14DCT = MS14 (see above), direct current, w/ thermal lockout MS14DCLCT = Low current MS14DCT	

NOTES:

Box 2. Double and triple stacking of K-size elements can be replaced by KK and 27K elements, respectively. Number of elements must equal 2 when using KK or 27K elements.

Box 3. Replacement element part numbers are identical to contents of Boxes 2, 3, 4, and 5. K25 is not available with EPR seals.

Box 5. For options H, V, and H.5, all aluminum parts are anodized. H.5 seal designation includes the following: EPR seals, stainless steel wire mesh on elements, and light oil coating on housing exterior. Viton® is a registered trademark of DuPont Dow Elastomers. Skydrol® is a registered trademark of Solutia Inc.

Medium Pressure Filter

RLD



Features and Benefits

- Lightweight duplex filter constructed of aluminum
- High chromium content aluminum alloy is water tolerant – anodization is not required for high water-based fluids (HWBF)
- Filter housings are designed to withstand pressure surges as well as high static pressure loads
- Screw-in bowl allows the filter element to be easily removed for replacement or cleaning
- Standard model supplied with drain plugs
- Standard Viton® seal on filter housing
- Filter contains an integrated equalization valve
- Pressure is equalized between filters by raising the change-over lever prior to switching it to the relevant filter side

100 gpm
380 L/min
 350 psi
24 bar

Model No. of filter in photograph is RLD25DNZ5S24DW.

Flow Rating:	Up to 100 gpm (380 L/min) for 150 SUS (32 cSt) fluids
Max. Operating Pressure:	350 psi (24 bar)
Min. Yield Pressure:	Contact factory
Rated Fatigue Pressure:	350 psi (24 bar)
Temp. Range:	-22°F to 250°F (-30°C to 121°C)
Bypass Setting:	Standard: 102 psi (7 bar) Optional: 43 psi (3.0 bar)
Porting Head:	Aluminum
Element Case:	Aluminum
Weight of RLD-25DN:	26 lbs. (11.8 kg)
Weight of RLD-40DN:	29 lbs. (13.0 kg)
Element Change Clearance:	25DN: 3.5" (89 mm) 40DN: 3.5" (89 mm)

Filter Housing Specifications

Type Fluid	Appropriate Schroeder Media
Petroleum Based Fluids	All Z-Media® (synthetic)
High Water Content	All Z-Media® (synthetic)
Invert Emulsions	10 and 25 μ Z-Media® (synthetic)
Water Glycols	3, 6, 10 and 25 μ Z-Media® (synthetic)

Fluid Compatibility

Accessories For Tank-Mounted Filters

- IRF
- TF1
- KF3
- KL3
- LF1
- MLF1
- RLD**
- GRTB
- MTA
- MTB
- ZT
- AFT
- KFT
- RT
- RTI
- LRT
- ART
- BRT
- TRT
- BFT
- QT
- KTK
- LTK
- MRT
- PAF1
- MAF1
- MF2

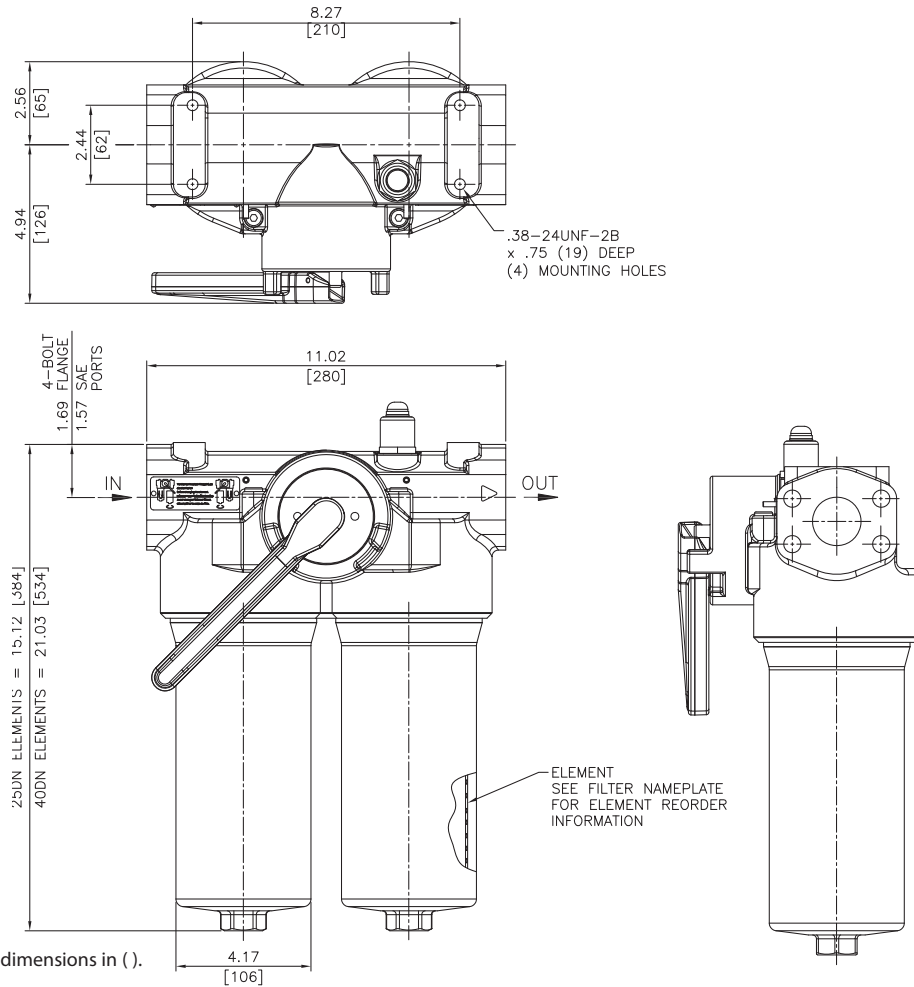

Metric dimensions in ().

Element Performance Information & Dirt Holding Capacity

Element	Filtration Ratio Per ISO 4572/NFPA T3.10.8.8 Using automated particle counter (APC) calibrated per ISO 4402			Filtration Ratio per ISO 16889 Using APC calibrated per ISO 11171	
	$\beta_x \geq 75$	$\beta_x \geq 100$	$\beta_x \geq 200$	$\beta_{x(c)} \geq 200$	$\beta_{x(c)} \geq 1000$
25/40DNZ3	<1.0	<1.0	<2.0	<4.0	4.8
25/40DNZ6	2.5	3.0	4.0	4.8	6.3
25/40DNZ10	7.4	8.2	10.0	8.0	10.0
25/40DNZ25	18.0	20.0	22.5	19.0	24.0

Element	DHC (gm)	Element	DHC (gm)
25DNZ3	57	40DNZ3	105
25DNZ6	62	40DNZ6	115
25DNZ10	52	40DNZ10	104
25DNZ25	48	40DNZ25	94

Element Collapse Rating: 290 psid (20 bar)
 Flow Direction: Outside In
 Element Nominal Dimensions: 3.0" (75 mm) O.D. x 14.5" (370 mm) long

$\Delta P_{\text{housing}}$

RLD $\Delta P_{\text{housing}}$ for fluids with sp gr (specific gravity) = 0.86:

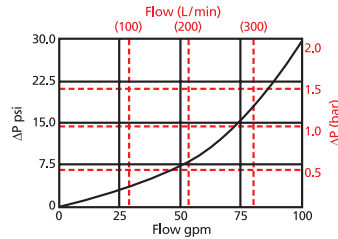

Pressure Drop Information Based on Flow Rate and Viscosity

$\Delta P_{\text{element}}$

25DNZ

Element Pressure Drop versus Flow Rate at 32 cSt (150 SUS)

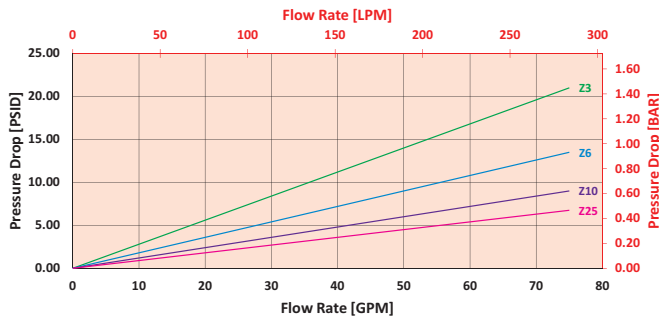

40DNZ

Element Pressure Drop versus Flow Rate at 32 cSt (150 SUS)

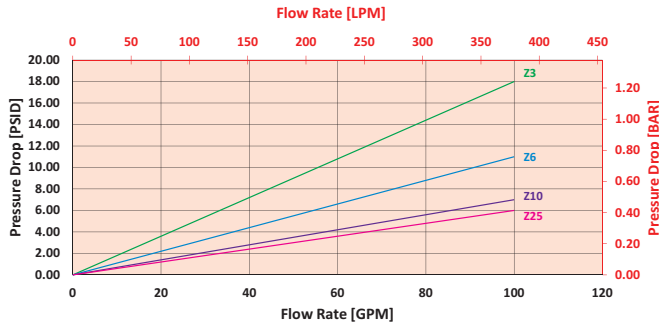

$$\Delta P_{\text{filter}} = \Delta P_{\text{housing}} + (\Delta P_{\text{element}} * V_f)$$

Exercise:

Determine ΔP_{filter} at 70 gpm (265.3 L/min) for RLD25DNZ5VF2440VM using 160 SUS (34 cSt) fluid.

Use the housing pressure curve to determine $\Delta P_{\text{housing}}$ at 70 gpm. In this case, $\Delta P_{\text{housing}}$ is 14 psi (.96 bar) on the graph for the RLD housing.

Use the element pressure curve to determine $\Delta P_{\text{element}}$ at 70 gpm. In this case, $\Delta P_{\text{element}}$ is 8 psi (.55 bar) according to the graph for the 25DNZ5V element.

Because the viscosity in this sample is 160 SUS (44 cSt), we determine the Viscosity Factor (V_f) by dividing the Operating Fluid Viscosity with the Standard Viscosity of 150 SUS (32 cSt). To best determine your Operating Fluid Viscosity, please reference the chart in Appendix D.

Finally, the overall filter pressure differential, ΔP_{filter} , is calculated by adding $\Delta P_{\text{housing}}$ with the true element pressure differential, ($\Delta P_{\text{element}} * V_f$). The $\Delta P_{\text{element}}$ from the graph has to be multiplied by the viscosity factor to get the true pressure differential across the element.

Solution:

$$\Delta P_{\text{housing}} = 14 \text{ psi } [.96 \text{ bar}] \mid \Delta P_{\text{element}} = 8 \text{ psi } [.55 \text{ bar}]$$

$$V_f = 160 \text{ SUS (34 cSt)} / 150 \text{ SUS (32 cSt)} = 1.1$$

$$\Delta P_{\text{filter}} = 14 \text{ psi} + (8 \text{ psi} * 1.1) = 22.8 \text{ psi}$$

OR

$$\Delta P_{\text{filter}} = .96 \text{ bar} + (.55 \text{ bar} * 1.1) = 1.6 \text{ bar}$$

Filter Model Number Selection

How to Build a Valid Model Number for a Schroeder RLD:

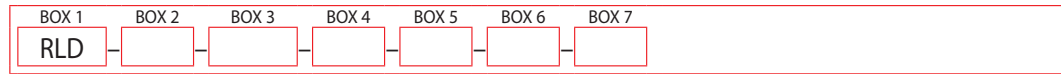

Example: NOTE: One option per box

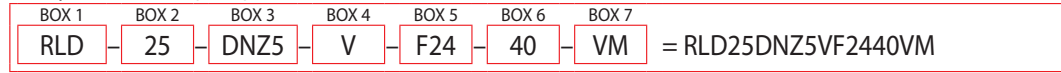

BOX 1	BOX 2	BOX 3	BOX 4
Filter Series	Length of Elements (cm)	Element Size and Media	Element Seal Material
RLD	25 40	DNZ5 = DN size 5 μ synthetic media DNZ10 = DN size 10 μ synthetic media DNZ25 = DN size 25 μ synthetic media DNM25 = DN size 25 μ M media (reuseable metal) DNM50 = DN size 50 μ M media (reuseable metal) DNM100 = DN size 100 μ M media (reuseable metal) DNM200 = DN size 200 μ M media (reuseable metal)	Omit = Buna N V = Viton®

BOX 5	BOX 6	BOX 7
Porting	Bypass Setting	Dirt Alarm® Options
F24 = 1½" SAE 4-bolt flange Code 61 S24 = SAE-24 (1½")	Omit = 102 psi cracking 40 = 43 psi cracking	Omit = None Visual VM = Visual pop-up w/manual reset Electrical DW = AC/DC 3-wire (NO or NC)



VM = Manual Reset

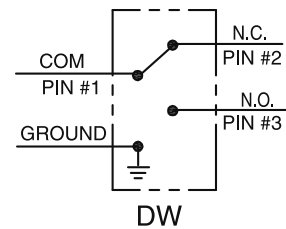

DW = AC/DC 3-wire (NO or NC)

NOTES:

Box 2. Replacement element part numbers are a combination of Boxes 2, 3 and 4. Example: 40DNZ10

Box 4. Filter housings are supplied with standard Viton seals. Seal designation in Box 4 applies to element only. Viton® is a registered trademark of DuPont Dow Elastomers.

Tank-Mounted Return Line Filter

GRTB



Features and Benefits

- Patented GeoSeal® Elements
- Various Dirt Alarm® options
- Cost optimized for in-tank applications
- Plastic bowl and cap lower cost and minimize weight
- UV resistant cap
- Same day shipment model available



Part of Schroeder Industries' Energy Sustainability Initiative

100 gpm
380 L/min
 100 psi
7 bar

Model No. of filter in photograph is GRTB1KBGZ10S.

Flow Rating: Up to 100 gpm (380 L/min) for 150 SUS (32 cSt) fluids	Filter Housing Specifications
Max. Operating Pressure: 100 psi (7 bar)	
Min. Yield Pressure: 400 psi (28 bar)	
Rated Fatigue Pressure: 145 psi (10 bar), Per NFPA T2.6.1-2005	
Temp. Range: -20°F to 200°F (-29°C to 93°C)	
Bypass Setting: Cracking: 25 psi (1.7 bar) Full Flow: 42 psi (2.9 bar)	
Cap & Bowl: Nylon Porting Head: Aluminum	
Weight of GRTB-1K: 5.2 lbs (2.36 kg)	
Element Change Clearance: 9.5" (240 mm)	

Type Fluid	Appropriate Schroeder Media	Fluid Compatibility
Petroleum Based Fluids	All E media (cellulose), Z-Media® and ASP® media (synthetic)	
Invert Emulsions	10 and 25 µ Z-Media® and 10 µ ASP® media (synthetic)	

- IRF
- TF1
- KF3
- KL3
- LF1
- MLF1
- RLD
- GRTB**
- MTA
- MTB
- ZT
- AFT
- KFT
- RT
- RTI
- LRT
- ART
- BRT
- TRT
- BFT
- QT
- KTK
- LTK
- MRT
- Accessories For Tank-Mounted Filters
- PAF1
- MAF1
- MF2

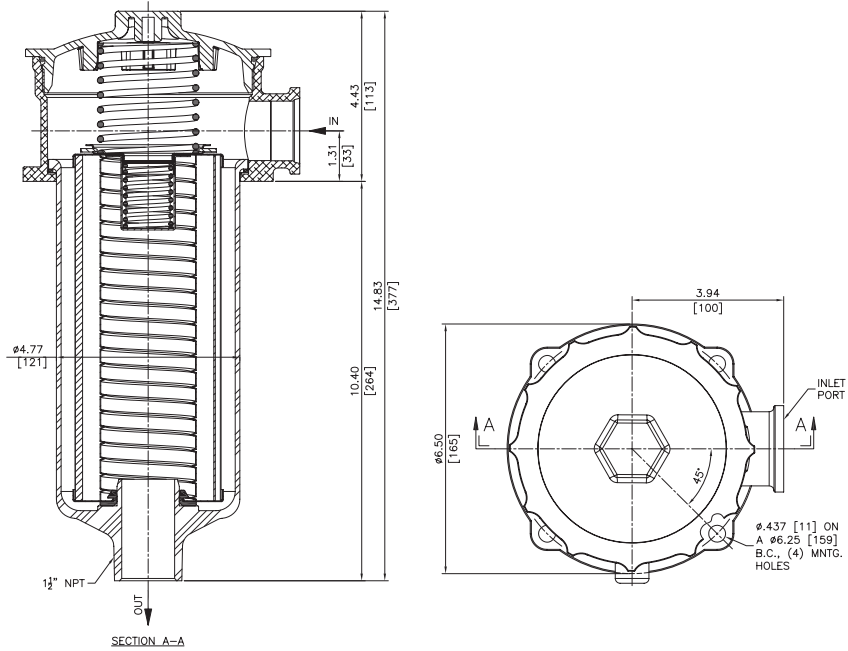

Metric dimensions in ().

Element Performance Information & Dirt Holding Capacity

Element	Filtration Ratio Per ISO 4572/NFPA T3.10.8.8 Using automated particle counter (APC) calibrated per ISO 4402			Filtration Ratio per ISO 16889 Using APC calibrated per ISO 11171	
	$\beta_x \geq 75$	$\beta_x \geq 100$	$\beta_x \geq 200$	$\beta_{x(c)} \geq 200$	$\beta_{x(c)} \geq 1000$
KBGZ1	<1.0	<1.0	<1.0	<4.0	4.2
KBGZ3	<1.0	<1.0	<2.0	<4.0	4.8
KBGZ5	2.5	3.0	4.0	4.8	6.3
KBGZ10	7.4	8.2	10.0	8.0	10.0
KBGZ25	18.0	20.0	22.5	19.0	24.0

Element	DHC (gm)
KBGZ1	112
KBGZ3	115
KBGZ5	119
KBGZ10	108
KBGZ25	93

Element Collapse Rating: 150 psid (10 bar) for standard elements

Flow Direction: Outside In

Element Nominal Dimensions: K: 3.9" (99 mm) O.D. x 9.0" (230 mm) long

$\Delta P_{\text{housing}}$

GRTB $\Delta P_{\text{housing}}$ for fluids with sp gr (specific gravity) = 0.86:

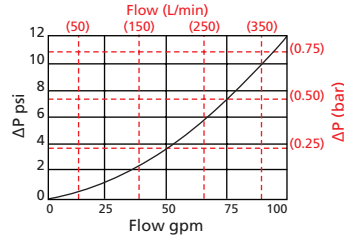

$\Delta P_{\text{element}}$

KBGZ

Element Pressure Drop versus Flow Rate at 32 cSt (150 SUS)

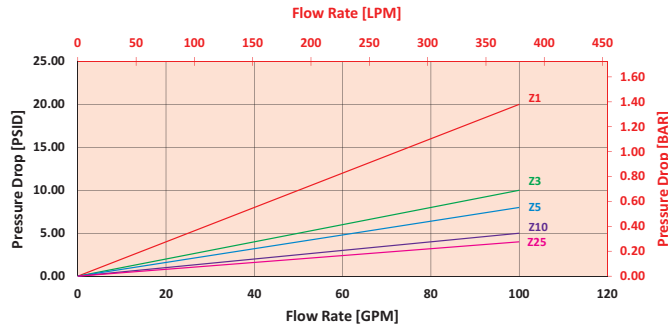

Pressure Drop Information Based on Flow Rate and Viscosity

$$\Delta P_{\text{filter}} = \Delta P_{\text{housing}} + (\Delta P_{\text{element}} * V_f)$$

Exercise:

Determine ΔP_{filter} at 80 gpm (303.2 L/min) for GRTB1KBGZ10PY2 using 160 SUS (34 cSt) fluid.

Use the housing pressure curve to determine $\Delta P_{\text{housing}}$ at 80 gpm. In this case, $\Delta P_{\text{housing}}$ is 8 psi (.55 bar) on the graph for the GRTB housing.

Use the element pressure curve to determine $\Delta P_{\text{element}}$ at 80 gpm. In this case, $\Delta P_{\text{element}}$ is 4 psi (.27 bar) according to the graph for the KBGZ10 element.

Because the viscosity in this sample is 160 SUS (34 cSt), we determine the Viscosity Factor (V_f) by dividing the Operating Fluid Viscosity with the Standard Viscosity of 150 SUS (32 cSt). To best determine your Operating Fluid Viscosity, please reference the chart in Appendix D.

Finally, the overall filter pressure differential, ΔP_{filter} , is calculated by adding $\Delta P_{\text{housing}}$ with the true element pressure differential, $(\Delta P_{\text{element}} * V_f)$. The $\Delta P_{\text{element}}$ from the graph has to be multiplied by the viscosity factor to get the true pressure differential across the element.

Solution:

$$\Delta P_{\text{housing}} = 8 \text{ psi } [.55 \text{ bar}] \quad | \quad \Delta P_{\text{element}} = 4 \text{ psi } [.27 \text{ bar}]$$

$$V_f = 160 \text{ SUS (34 cSt)} / 150 \text{ SUS (32 cSt)} = 1.1$$

$$\Delta P_{\text{filter}} = 8 \text{ psi} + (4 \text{ psi} * 1.1) = 12.4 \text{ psi}$$

OR

$$\Delta P_{\text{filter}} = .55 \text{ bar} + (.27 \text{ bar} * 1.1) = .85 \text{ bar}$$

Filter Model Number Selection

Highlighted product eligible for **QuickDelivery**

How to Build a Valid Model Number for a Schroeder GRTB:

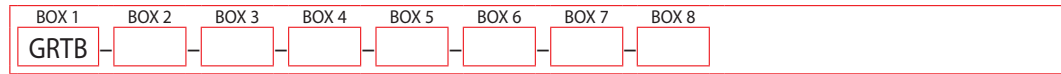

Example: NOTE: One option per box

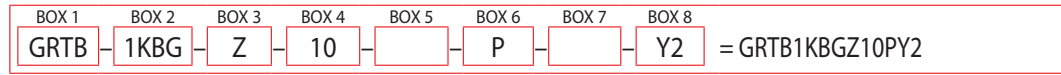

BOX 1	BOX 2	BOX 3	BOX 4
Filter Series	Element Size	Media Type	Micron Rating
GRTB (GeoSeal®)	1KBG (GeoSeal®)	Omit = E-Media (cellulose)	1 = 1 μ Z-Media*
RTB	1KB	Z = Excellement® Z-Media*	3 = 3 μ Z-Media*
			5 = 5 μ Z-Media*
			10 = 10 μ E, and Z-Media*
			25 = 25 μ E, and Z-Media*

BOX 5	BOX 6	BOX 7
Seals	Port	Outlet Porting Options
Omit = Buna N	P = 1.25" NPT	Omit = 1 1/2" NPT male
	S = SAE-20	C = Check valve
	B = ISO 228 G-1.25"	D = Diffuser
		CD = Check valve & diffuser
		T = 13" Tube extension

BOX 8
Indicator
Omit = None
Y2 = Back-mounted tricolor gauge
ES = Electric switch
ES1 = Heavy-duty electric switch with conduit connections
ES2 = Electrical Switch with Deutsch Connector
ES3 = Electric Switch with DIN 43650

NOTES:

Box 3. Use boxes 2, 3, 4, and 5 to build a replacement element part number.

MiniMiser™ Tank-Mounted Filter

MTA

IRF

TF1

KF3

KL3

LF1

MLF1

RLD

GRTB

MTA

MTB

ZT

AFT

KFT

RT

RTI

LRT

ART

BRT

TRT

BFT

QT

KTK

LTK

MRT

Accessories
For Tank-
Mounted
Filters

PAF1

MAF1

MF2



Features and Benefits

- Low pressure tank-mounted filter
- Compact size minimizes space requirements
- Minimizer is cost-effective alternative to spin-on filters
- Special filter element design provides aftermarket benefits

15 gpm
55 L/min
100 psi
7 bar

Model No. of filter in photograph is MTA3TAZ10P8.

Flow Rating:	Up to 15 gpm (55 L/min) for 150 SUS (32 cSt) fluids
Max. Operating Pressure:	100 psi (7 bar)
Min. Yield Pressure:	269 psi (18 bar), per NFPA T2.6.1
Rated Fatigue Pressure:	Contact factory
Temp. Range:	-20°F to 225°F (-29°C to 107°C)
Bypass Setting:	Cracking: 25 psi (2 bar) Full Flow: 48 psi (3.3 bar)
Porting Head & Cap:	Die Cast Aluminum
Element Case:	Glass Filled Nylon
Weight of MTA-3:	1.0 lbs. (0.5 kg)
Element Change Clearance:	3.0" (76 mm)

Filter
Housing
Specifications

Type Fluid	Appropriate Schroeder Media
Petroleum Based Fluids	All E media (cellulose) and Z-Media* (synthetic)

Fluid
Compatibility

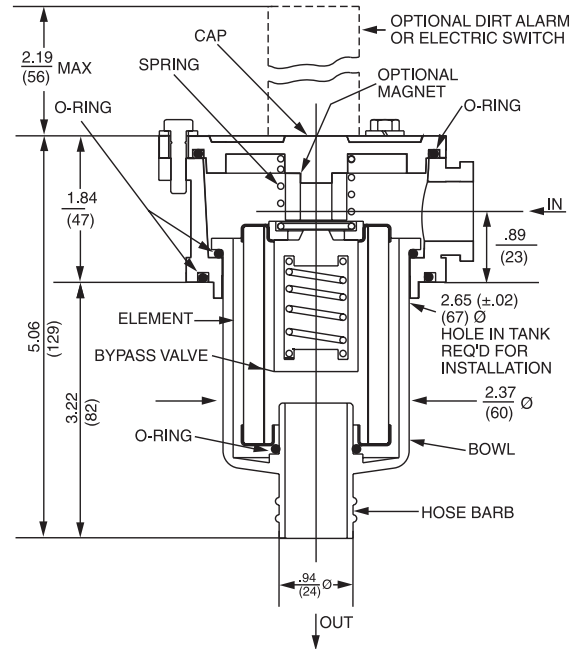
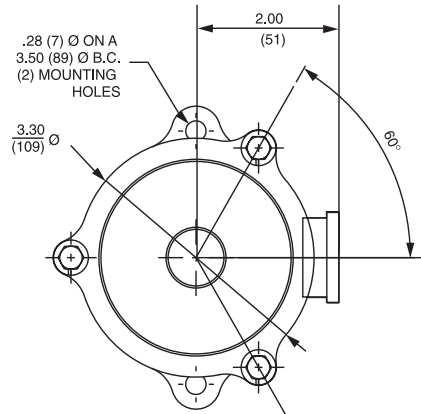

Metric dimensions in ().

Element Performance Information & Dirt Holding Capacity

Element	Filtration Ratio Per ISO 4572/NFPA T3.10.8.8 Using automated particle counter (APC) calibrated per ISO 4402			Filtration Ratio per ISO 16889 Using APC calibrated per ISO 11171	
	$\beta_x \geq 75$	$\beta_x \geq 100$	$\beta_x \geq 200$	$\beta_x(c) \geq 200$	$\beta_x(c) \geq 1000$
3TAZ3	<1.0	<1.0	<2.0	<4.0	4.8
3TAZ5	2.5	3.0	4.0	4.8	6.3
3TAZ10	7.4	8.2	10.0	8.0	10.0
3TAZ25	18.0	20.0	22.5	19.0	24.0

Element	DHC (gm)
3TAZ3	4
3TAZ5	6
3TAZ10	4
3TAZ25	4

Element Collapse Rating: 150 psid (10 bar)
 Flow Direction: Outside In
 Element Nominal Dimensions: 2.0" (51 mm) O.D. x 3.0" (76 mm) long

$\Delta P_{\text{housing}}$

MTA $\Delta P_{\text{housing}}$ for fluids with sp gr (specific gravity) = 0.86:

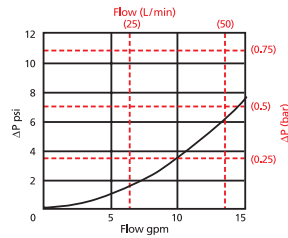

$\Delta P_{\text{element}}$

3TAZ

Element Pressure Drop versus Flow Rate at 32 cSt (150 SUS)

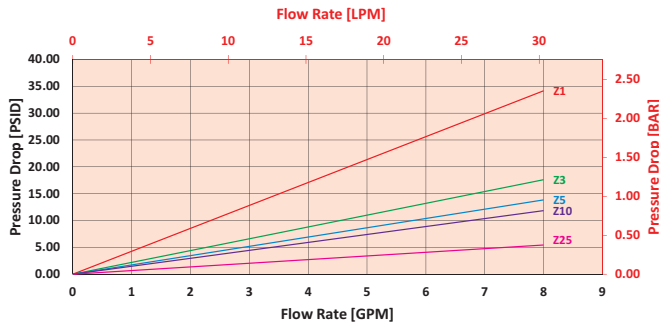

$$\Delta P_{\text{filter}} = \Delta P_{\text{housing}} + (\Delta P_{\text{element}} * V_f)$$

Exercise:

Determine ΔP_{filter} at 10 gpm (37.9 L/min) for MTA3TAZ25P8Y5 using 160 SUS (34 cSt) fluid.

Use the housing pressure curve to determine $\Delta P_{\text{housing}}$ at 10 gpm. In this case, $\Delta P_{\text{housing}}$ is 4 psi (.27 bar) on the graph for the MTA housing.

Use the element pressure curve to determine $\Delta P_{\text{element}}$ at 10 gpm. In this case, $\Delta P_{\text{element}}$ is 7 psi (.48 bar) according to the graph for the 3TAZ25 element.

Because the viscosity in this sample is 160 SUS (34 cSt), we determine the Viscosity Factor (V_f) by dividing the Operating Fluid Viscosity with the Standard Viscosity of 150 SUS (32 cSt). To best determine your Operating Fluid Viscosity, please reference the chart in Appendix D.

Finally, the overall filter pressure differential, ΔP_{filter} , is calculated by adding $\Delta P_{\text{housing}}$ with the true element pressure differential, ($\Delta P_{\text{element}} * V_f$). The $\Delta P_{\text{element}}$ from the graph has to be multiplied by the viscosity factor to get the true pressure differential across the element.

Solution:

$$\Delta P_{\text{housing}} = 4 \text{ psi } [.27 \text{ bar}] \mid \Delta P_{\text{element}} = 7 \text{ psi } [.48 \text{ bar}]$$

$$V_f = 160 \text{ SUS (34 cSt)} / 150 \text{ SUS (32 cSt)} = 1.1$$

$$\Delta P_{\text{filter}} = 4 \text{ psi} + (7 \text{ psi} * 1.1) = 11.7 \text{ psi}$$

OR

$$\Delta P_{\text{filter}} = .27 \text{ bar} + (.48 \text{ bar} * 1.1) = .80 \text{ bar}$$

Pressure Drop Information Based on Flow Rate and Viscosity

Note: If your element is not graphed, use the following equation: $\Delta P_{\text{element}} = \text{Flow Rate} \times \Delta P_f$. Plug this variable into the overall pressure drop equation.

Ele.	ΔP
3TA10	1.40
3TA25	0.33

Filter Model Number Selection

How to Build a Valid Model Number for a Schroeder MTA:

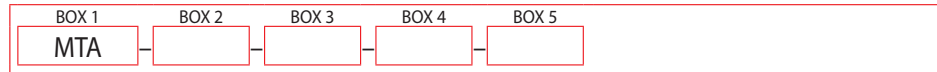

Example: NOTE: One option per box

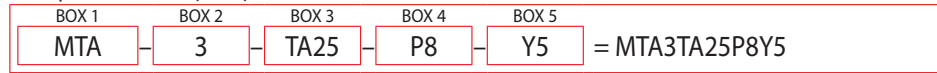

BOX 1	BOX 2	BOX 3
Filter Series	Element Length (in)	Element Size and Media
MTA	3	TA10 = TA size 10 μ E media (cellulose) TA25 = TA size 25 μ E media (cellulose) TAZ1 = TA size 1 μ Excellement® Z-Media® (synthetic) TAZ3 = TA size 3 μ Excellement® Z-Media® (synthetic) TAZ5 = TA size 5 μ Excellement® Z-Media® (synthetic) TAZ10 = TA size 10 μ Excellement® Z-Media® (synthetic) TAZ25 = TA size 25 μ Excellement® Z-Media® (synthetic)

BOX 4	BOX 5
Porting Options	Dirt Alarm® Options
P8 = ½" NPTF S8 = SAE-8	Omit = None Visual Y2C = Bottom-mounted gauge in cap Y5 = Back-mounted gauge in cap Electrical ESC = Electric pressure switch (2 terminals)

MiniMiser™ Tank-Mounted Filter

MTB



Features and Benefits

- Low pressure tank-mounted filter
- Compact size minimizes space requirements
- Minimizer is cost-effective alternative to spin-on filters
- Special filter element design provides aftermarket benefits

35 gpm
135 L/min
 100 psi
 7 bar

Model No. of filter in photograph is MTB5TBZ5P16H.

Flow Rating:	Up to 25 gpm (95 L/min) for 150 SUS (32 cSt) fluids–MTB-3 Up to 35 gpm (135 L/min) for 150 SUS (32 cSt) fluids–MTB-5
Max. Operating Pressure:	100 psi (7 bar)
Min. Yield Pressure:	229 psi (15 bar), per NFPA T2.6.1
Rated Fatigue Pressure:	Contact factory
Temp. Range:	-20°F to 225°F (-29°C to 107°C)
Bypass Setting:	Cracking: 25 psi (2 bar) Full Flow: 51 psi (3.5 bar)
Porting Head & Cap:	Die Cast Aluminum
Element Case:	Glass Filled Nylon
Weight of MTB-3:	1.8 lbs. (0.8 kg)
Weight of MTB-5:	2.1 lbs. (1.0 kg)
Element Change Clearance:	3.0" (76 mm) MTB-3 5.0" (127 mm) MTB-5

Filter Housing Specifications

Type Fluid	Appropriate Schroeder Media
Petroleum Based Fluids	All E media (cellulose) and Z-Media* (synthetic)

Fluid Compatibility

Accessories For Tank-Mounted Filters

- IRF
- TF1
- KF3
- KL3
- LF1
- MLF1
- RLD
- GRTB
- MTA
- MTB**
- ZT
- AFT
- KFT
- RT
- RTI
- LRT
- ART
- BRT
- TRT
- BFT
- QT
- KTK
- LTK
- MRT
- PAF1
- MAF1
- MF2

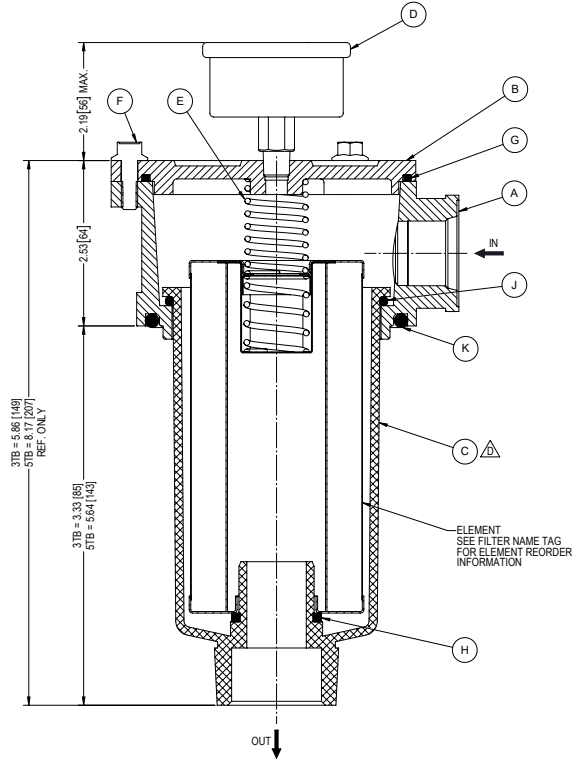
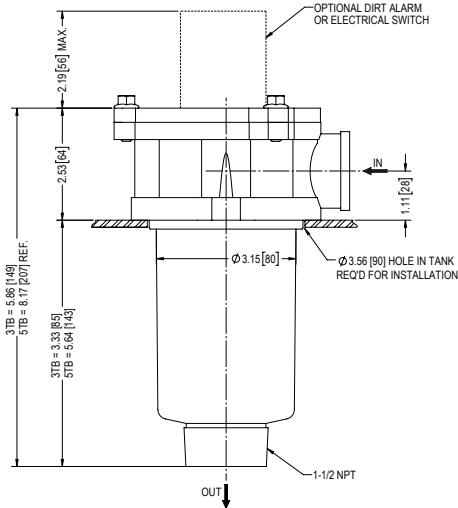
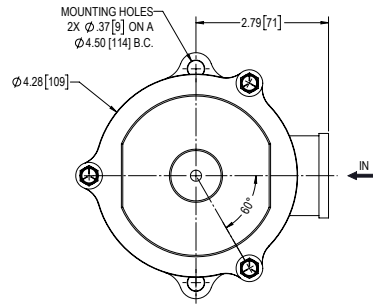

Metric dimensions in ().

Element Performance Information & Dirt Holding Capacity

Element	Filtration Ratio Per ISO 4572/NFPA T3.10.8.8 Using automated particle counter (APC) calibrated per ISO 4402			Filtration Ratio per ISO 16889 Using APC calibrated per ISO 11171	
	$\beta_x \geq 75$	$\beta_x \geq 100$	$\beta_x \geq 200$	$\beta_{x(c)} \geq 200$	$\beta_{x(c)} \geq 1000$
3TBZ3	<1.0	<1.0	<2.0	<4.0	4.8
3TBZ5	2.5	3.0	4.0	4.8	6.3
3TBZ10	7.4	8.2	10.0	8.0	10.0
3TBZ25	18.0	20.0	22.5	19.0	24.0
5TBZ3	<1.0	<1.0	<2.0	4.7	5.8
5TBZ5	2.5	3.0	4.0	5.6	7.2
5TBZ10	7.4	8.2	10.0	8.0	9.8
5TBZ25	18.0	20.0	22.5	19.0	24.0

Element	DHC (gm)
3TBZ3	11
3TBZ5	12
3TBZ10	11
3TBZ25	11
5TBZ3	18
5TBZ5	21
5TBZ10	17
5TBZ25	18

Element Collapse Rating: 150 psid (10 bar)

Flow Direction: Outside In

Element Nominal Dimensions: 3TB: 3.0" (76 mm) O.D. x 3.0" (76 mm) long
5TB: 3.0" (76 mm) O.D. x 5.0" (127 mm) long

$\Delta P_{\text{housing}}$

MTB $\Delta P_{\text{housing}}$ for fluids with sp gr (specific gravity) = 0.86:

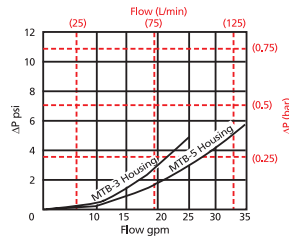

$\Delta P_{\text{element}}$

3TBZ

Element Pressure Drop versus Flow Rate at 32 cSt (150 SUS)

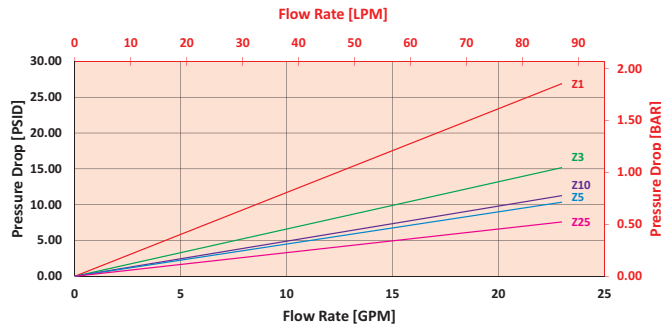

5TBZ

Element Pressure Drop versus Flow Rate at 32 cSt (150 SUS)

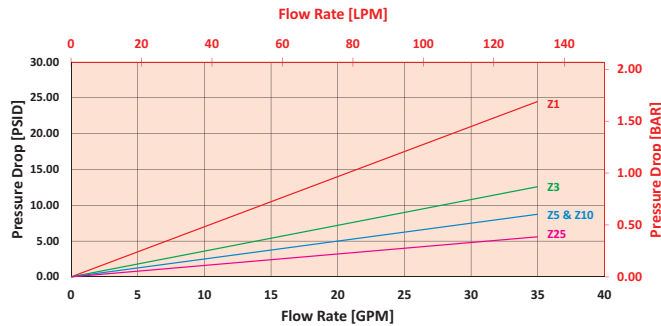

$$\Delta P_{\text{filter}} = \Delta P_{\text{housing}} + (\Delta P_{\text{element}} * V_f)$$

Exercise:

Determine ΔP_{filter} at 10 gpm (37.9 L/min) for MTB3TBZ25P12Y5 using 160 SUS (34 cSt) fluid.

Use the housing pressure curve to determine $\Delta P_{\text{housing}}$ at 10 gpm. In this case, $\Delta P_{\text{housing}}$ is 1 psi (.07 bar) on the graph for the MTB housing.

Use the element pressure curve to determine $\Delta P_{\text{element}}$ at 10 gpm. In this case, $\Delta P_{\text{element}}$ is 3 psi (.21 bar) according to the graph for the 3TBZ25 element.

Because the viscosity in this sample is 160 SUS (34 cSt), we determine the Viscosity Factor (V_f) by dividing the Operating Fluid Viscosity with the Standard Viscosity of 150 SUS (32 cSt). To best determine your Operating Fluid Viscosity, please reference the chart in Appendix D.

Finally, the overall filter pressure differential, ΔP_{filter} , is calculated by adding $\Delta P_{\text{housing}}$ with the true element pressure differential, ($\Delta P_{\text{element}} * V_f$). The $\Delta P_{\text{element}}$ from the graph has to be multiplied by the viscosity factor to get the true pressure differential across the element.

Solution:

$$\Delta P_{\text{housing}} = 1 \text{ psi } [.07 \text{ bar}] \mid \Delta P_{\text{element}} = 3 \text{ psi } [.21 \text{ bar}]$$

$$V_f = 160 \text{ SUS (34 cSt)} / 150 \text{ SUS (32 cSt)} = 1.1$$

$$\Delta P_{\text{filter}} = 1 \text{ psi} + (3 \text{ psi} * 1.1) = 4.3 \text{ psi}$$

OR

$$\Delta P_{\text{filter}} = .07 \text{ bar} + (.21 \text{ bar} * 1.1) = .30 \text{ bar}$$

Pressure Drop Information Based on Flow Rate and Viscosity

Note: If your element is not graphed, use the following equation:
 $\Delta P_{\text{element}} = \text{Flow Rate} \times \Delta P_f$ Plug this variable into the overall pressure drop equation.

Ele.	ΔP	Ele.	ΔP
3TB10	1.40	5TB10	0.40
3TB25	0.10	5TB25	0.08

Filter Model Number Selection

How to Build a Valid Model Number for a Schroeder MTB:

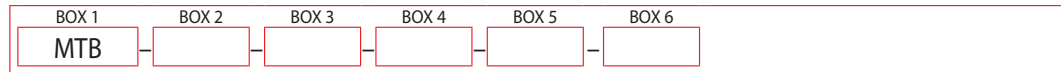

Example: NOTE: One option per box

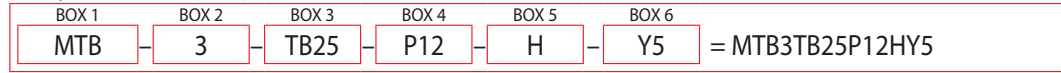

BOX 1	BOX 2	BOX 3
Filter Series	Element Length (in)	Element Size and Media
MTB	3	TB10 = T size 10 μ E media (cellulose)
	5	TB25 = T size 25 μ E media (cellulose)
		TBZ3 = T size 3 μ Excellement® Z-Media® (synthetic)
		TBZ5 = T size 5 μ Excellement® Z-Media® (synthetic)
		TBZ10 = T size 10 μ Excellement® Z-Media® (synthetic)
		TBZ25 = T size 25 μ Excellement® Z-Media® (synthetic)

BOX 4	BOX 5	BOX 6
Porting Options	Outlet Options	Dirt Alarm® Options
P12 = ¾" NPTF	Omit = 1.5" NPT Outlet	Omit = None
P16 = 1" NPTF	H = Hose Barb Outlet	Visual Y2C = Bottom-mounted gauge in cap
S12 = SAE-12	D = Diffuser	Y5 = Back-mounted gauge in cap
S16 = SAE-16		Electrical ESC = Electric pressure switch (2 terminals)
B12 = ISO 228 G-¾"		
B16 = ISO 228 G-1"		

Tank-Mounted Filter

ZT



Features and Benefits

- Low pressure tank-mounted filter
 - Available with dual inlet porting
 - Offered in pipe, SAE straight thread and ISO 228 porting
 - Various Dirt Alarm[®] options
 - Optional PAB1 breather
 - Available with quality-protected GeoSeal[®] Elements (GZT)
- G** Same day shipment model available



Part of Schroeder Industries' Energy Sustainability Initiative

40 gpm
150 L/min
 100 psi
 7 bar

Model No. of filter in photograph is ZT8ZZ10PPESAB.

- IRF
- TF1
- KF3
- KL3
- LF1
- MLF1
- RLD
- GRTB
- MTA
- MTB
- ZT**
- AFT
- KFT
- RT
- RTI
- LRT
- ART
- BRT
- TRT
- BFT
- QT
- KTK
- LTK
- MRT

Flow Rating:	Up to 40 gpm (150 L/min) for 150 SUS (32 cSt) fluids
Max. Operating Pressure:	100 psi (7 bar)
Min. Yield Pressure:	300 psi (21 bar), per NFPA T2.6.1
Rated Fatigue Pressure:	90 psi (6 bar), per NFPA T2.6.1-R1-2005
Temp. Range:	-20°F to 225°F (-29°C to 107°C)
Bypass Setting:	Cracking: 25 psi (1.7 bar) Full Flow: 39 psi (2.7 bar)
Cap & Bowl:	Nylon
Porting Head:	Aluminum
Weight of ZT-8Z:	3.3 lbs. (1.49 kg)
Element Change Clearance:	10.0" (254 mm)

Filter Housing Specifications

Type Fluid	Appropriate Schroeder Media
Petroleum Based Fluids	All E media (cellulose) and Z-Media [®] (synthetic)
High Water Content	All Z-Media (synthetic)
Invert Emulsions	10 and 25 μ Z-Media [®] (synthetic)
Water Glycols	3, 5, 10 and 25 μ Z-Media [®] (synthetic)
Phosphate Esters	All Z-Media [®] (synthetic) with H (EPR) seal designation

Fluid Compatibility

Accessories For Tank-Mounted Filters

- PAF1
- MAF1
- MF2

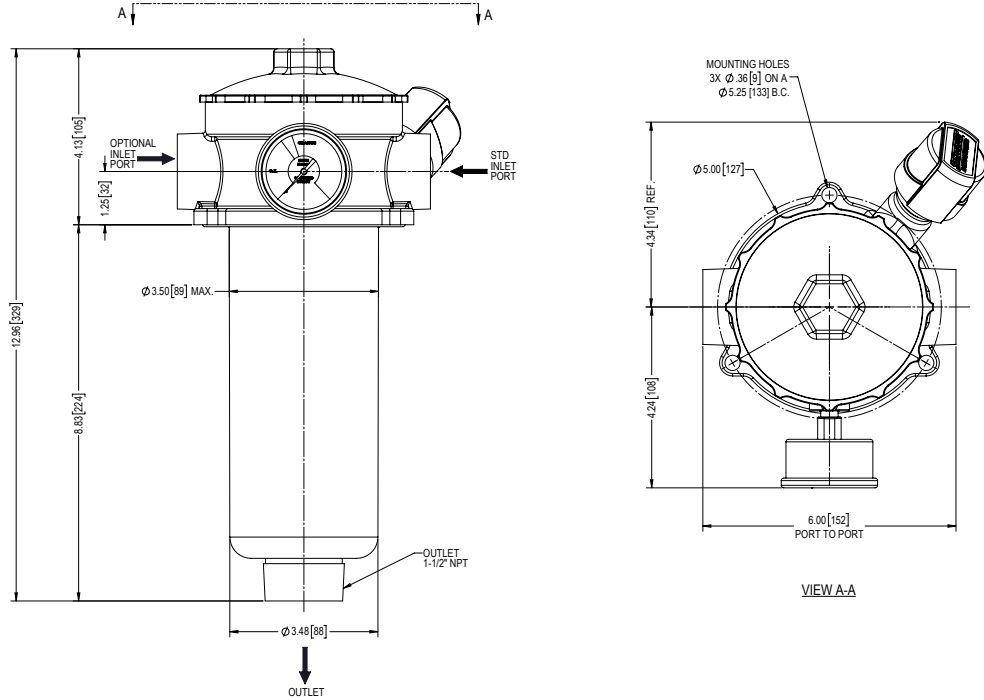

Metric dimensions in ().

Element Performance Information & Dirt Holding Capacity

Element	Filtration Ratio Per ISO 4572/NFPA T3.10.8.8 Using automated particle counter (APC) calibrated per ISO 4402			Filtration Ratio wrt ISO 16889 Using APC calibrated per ISO 11171	
	$\beta_x \geq 75$	$\beta_x \geq 100$	$\beta_x \geq 200$	$\beta_{x(c)} \geq 200$	$\beta_{x(c)} \geq 1000$
8Z3	6.8	7.5	10.0	N/A	N/A
8Z10	15.5	16.2	18.0	N/A	N/A
8ZZ1	<1.0	<1.0	<1.0	<4.0	4.2
8ZZ3	<1.0	<1.0	<2.0	<4.0	4.8
8ZZ5	2.5	3.0	4.0	4.8	6.3
8ZZ10	7.4	8.2	10.0	8.0	10.0
8ZZ25	18.0	20.0	22.5	19.0	24.0

Element	DHC (gm)
8Z3	39
8Z10	32
8ZZ1	51
8ZZ3	52
8ZZ5	59
8ZZ10	55
8ZZ25	77

Element Collapse Rating: 150 psid (10 bar)

Flow Direction: Outside In

Element Nominal Dimensions: 3.2" (81 mm) O.D. x 9.25" (235 mm) long

$\Delta P_{\text{housing}}$

ZT $\Delta P_{\text{housing}}$ for fluids with sp gr (specific gravity) = 0.86:

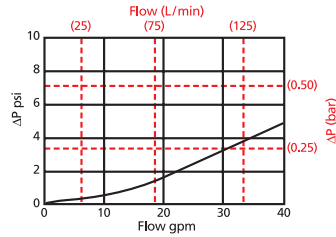

$\Delta P_{\text{element}}$

8ZZ

Element Pressure Drop versus Flow Rate at 32 cSt (150 SUS)

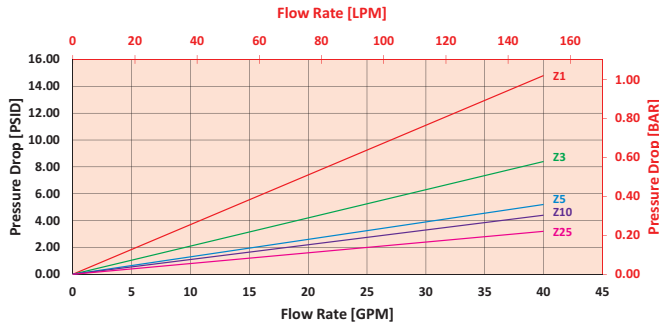

$$\Delta P_{\text{filter}} = \Delta P_{\text{housing}} + (\Delta P_{\text{element}} * V_f)$$

Exercise:

Determine ΔP_{filter} at 30 gpm (119.7 L/min) for ZT8ZZ10SY2 using 160 SUS (34 cSt) fluid.

Use the housing pressure curve to determine $\Delta P_{\text{housing}}$ at 30 gpm. In this case, $\Delta P_{\text{housing}}$ is 3.5 psi (.24 bar) on the graph for the ZT housing.

Use the element pressure curve to determine $\Delta P_{\text{element}}$ at 30 gpm. In this case, $\Delta P_{\text{element}}$ is 3.5 psi (.24 bar) according to the graph for the 8ZZ10 element.

Because the viscosity in this sample is 160 SUS (34 cSt), we determine the Viscosity Factor (V_f) by dividing the Operating Fluid Viscosity with the Standard Viscosity of 150 SUS (32 cSt). To best determine your Operating Fluid Viscosity, please reference the chart in Appendix D.

Finally, the overall filter pressure differential, ΔP_{filter} , is calculated by adding $\Delta P_{\text{housing}}$ with the true element pressure differential, ($\Delta P_{\text{element}} * V_f$). The $\Delta P_{\text{element}}$ from the graph has to be multiplied by the viscosity factor to get the true pressure differential across the element.

Solution:

$\Delta P_{\text{housing}} = 3.5 \text{ psi } [.24 \text{ bar}] \mid \Delta P_{\text{element}} = 3.5 \text{ psi } [.24 \text{ bar}]$

$V_f = 160 \text{ SUS (34 cSt)} / 150 \text{ SUS (32 cSt)} = 1.1$

$\Delta P_{\text{filter}} = 3.5 \text{ psi} + (3.5 \text{ psi} * 1.1) = 7.4 \text{ psi}$

OR

$\Delta P_{\text{filter}} = .24 \text{ bar} + (.24 \text{ bar} * 1.1) = .50 \text{ bar}$

Pressure Drop Information Based on Flow Rate and Viscosity

Note: If your element is not graphed, use the following equation:
 $\Delta P_{\text{element}} = \text{Flow Rate} \times \Delta P_f$. Plug this variable into the overall pressure drop equation.

Ele.	ΔP
8Z3	0.25
8Z10	0.09
8Z25	0.02

Filter Model Number Selection

Highlighted product eligible for **QuickDelivery**

How to Build a Valid Model Number for a Schroeder ZT:

BOX 1	BOX 2	BOX 3	BOX 4	BOX 5	BOX 6	BOX 7	BOX 8
ZT							

Example: NOTE: One option per box

BOX 1	BOX 2	BOX 3	BOX 4	BOX 5	BOX 6	BOX 7	BOX 8
ZT	8	Z10		S	Y2		

= ZT8Z10SY2

BOX 1	BOX 2	BOX 3	BOX 4																									
<table border="1"> <tr><th>Filter Series</th></tr> <tr><td>ZT</td></tr> <tr><td>GZT (GeoSeal®)</td></tr> </table>	Filter Series	ZT	GZT (GeoSeal®)	<table border="1"> <tr><th>Element Length (in)</th></tr> <tr><td>8</td></tr> </table>	Element Length (in)	8	<table border="1"> <tr><th>Element Size and Media</th></tr> <tr><td>Z3 = Z size 3 μ E media (cellulose)</td></tr> <tr><td>Z10 = Z size 10 μ E media (cellulose)</td></tr> <tr><td>Z25 = Z size 25 μ E media (cellulose)</td></tr> <tr><td>ZZ1 = Z size 1 μ Excellement® Z-Media® (synthetic)</td></tr> <tr><td>ZZ3 = Z size 3 μ Excellement® Z-Media® (synthetic)</td></tr> <tr><td>ZZ5 = Z size 5 μ Excellement® Z-Media® (synthetic)</td></tr> <tr><td>ZZ10 = Z size 10 μ Excellement® Z-Media® (synthetic)</td></tr> <tr><td>ZZ25 = Z size 25 μ Excellement® Z-Media® (synthetic)</td></tr> <tr><td>GeoSeal® Element Options</td></tr> <tr><td>GZ3 = Z size 3 μ E media (cellulose)</td></tr> <tr><td>GZ10 = Z size 10 μ E media (cellulose)</td></tr> <tr><td>GZ25 = Z size 25 μ E media (cellulose)</td></tr> <tr><td>GTZZ1 = Z size 1 μ Excellement® Z-Media® (synthetic)</td></tr> <tr><td>GTZZ3 = Z size 3 μ Excellement® Z-Media® (synthetic)</td></tr> <tr><td>GTZZ5 = Z size 5 μ Excellement® Z-Media® (synthetic)</td></tr> <tr><td>GTZZ10 = Z size 10 μ Excellement® Z-Media® (synthetic)</td></tr> <tr><td>GTZZ25 = Z size 25 μ Excellement® Z-Media® (synthetic)</td></tr> </table>	Element Size and Media	Z3 = Z size 3 μ E media (cellulose)	Z10 = Z size 10 μ E media (cellulose)	Z25 = Z size 25 μ E media (cellulose)	ZZ1 = Z size 1 μ Excellement® Z-Media® (synthetic)	ZZ3 = Z size 3 μ Excellement® Z-Media® (synthetic)	ZZ5 = Z size 5 μ Excellement® Z-Media® (synthetic)	ZZ10 = Z size 10 μ Excellement® Z-Media® (synthetic)	ZZ25 = Z size 25 μ Excellement® Z-Media® (synthetic)	GeoSeal® Element Options	GZ3 = Z size 3 μ E media (cellulose)	GZ10 = Z size 10 μ E media (cellulose)	GZ25 = Z size 25 μ E media (cellulose)	GTZZ1 = Z size 1 μ Excellement® Z-Media® (synthetic)	GTZZ3 = Z size 3 μ Excellement® Z-Media® (synthetic)	GTZZ5 = Z size 5 μ Excellement® Z-Media® (synthetic)	GTZZ10 = Z size 10 μ Excellement® Z-Media® (synthetic)	GTZZ25 = Z size 25 μ Excellement® Z-Media® (synthetic)	<table border="1"> <tr><th>Seal Material</th></tr> <tr><td>Omit = Buna N</td></tr> </table>	Seal Material	Omit = Buna N
Filter Series																												
ZT																												
GZT (GeoSeal®)																												
Element Length (in)																												
8																												
Element Size and Media																												
Z3 = Z size 3 μ E media (cellulose)																												
Z10 = Z size 10 μ E media (cellulose)																												
Z25 = Z size 25 μ E media (cellulose)																												
ZZ1 = Z size 1 μ Excellement® Z-Media® (synthetic)																												
ZZ3 = Z size 3 μ Excellement® Z-Media® (synthetic)																												
ZZ5 = Z size 5 μ Excellement® Z-Media® (synthetic)																												
ZZ10 = Z size 10 μ Excellement® Z-Media® (synthetic)																												
ZZ25 = Z size 25 μ Excellement® Z-Media® (synthetic)																												
GeoSeal® Element Options																												
GZ3 = Z size 3 μ E media (cellulose)																												
GZ10 = Z size 10 μ E media (cellulose)																												
GZ25 = Z size 25 μ E media (cellulose)																												
GTZZ1 = Z size 1 μ Excellement® Z-Media® (synthetic)																												
GTZZ3 = Z size 3 μ Excellement® Z-Media® (synthetic)																												
GTZZ5 = Z size 5 μ Excellement® Z-Media® (synthetic)																												
GTZZ10 = Z size 10 μ Excellement® Z-Media® (synthetic)																												
GTZZ25 = Z size 25 μ Excellement® Z-Media® (synthetic)																												
Seal Material																												
Omit = Buna N																												
<table border="1"> <tr><th>BOX 5</th></tr> <tr><th>Inlet Porting</th></tr> <tr><td>P = 1" NPTF</td></tr> <tr><td>PP = Dual 1" NPTF</td></tr> <tr><td>S = SAE-16</td></tr> <tr><td>SS = Dual SAE-16</td></tr> <tr><td>B = ISO 228 G-1"</td></tr> <tr><td>BB = Dual ISO 228 G-1"</td></tr> </table>	BOX 5	Inlet Porting	P = 1" NPTF	PP = Dual 1" NPTF	S = SAE-16	SS = Dual SAE-16	B = ISO 228 G-1"	BB = Dual ISO 228 G-1"	<table border="1"> <tr><th>BOX 6</th></tr> <tr><th>Dirt Alarm® Options</th></tr> <tr><td>Omit = None</td></tr> <tr><td>Visual</td></tr> <tr><td>Y2 = Back-mounted tri-color gauge</td></tr> <tr><td>Y2C = Bottom-mounted gauge in cap</td></tr> <tr><td>Y5 = Back-mounted gauge in cap</td></tr> <tr><td>Electrical</td></tr> <tr><td>ES = Electric switch</td></tr> <tr><td>ES1 = Heavy-duty electric switch with conduit connection</td></tr> <tr><td>ES2 = Electrical Switch with Deutsch Connector</td></tr> </table>	BOX 6	Dirt Alarm® Options	Omit = None	Visual	Y2 = Back-mounted tri-color gauge	Y2C = Bottom-mounted gauge in cap	Y5 = Back-mounted gauge in cap	Electrical	ES = Electric switch	ES1 = Heavy-duty electric switch with conduit connection	ES2 = Electrical Switch with Deutsch Connector	<table border="1"> <tr><th>BOX 7</th></tr> <tr><th>Outlet Porting</th></tr> <tr><td>Omit = 1½" NPT male</td></tr> <tr><td>D = Diffuser</td></tr> <tr><td>T = 13" Tube Extension</td></tr> <tr><td>G3039 = 1.5" NPT outlet removed</td></tr> </table>	BOX 7	Outlet Porting	Omit = 1½" NPT male	D = Diffuser	T = 13" Tube Extension	G3039 = 1.5" NPT outlet removed	
BOX 5																												
Inlet Porting																												
P = 1" NPTF																												
PP = Dual 1" NPTF																												
S = SAE-16																												
SS = Dual SAE-16																												
B = ISO 228 G-1"																												
BB = Dual ISO 228 G-1"																												
BOX 6																												
Dirt Alarm® Options																												
Omit = None																												
Visual																												
Y2 = Back-mounted tri-color gauge																												
Y2C = Bottom-mounted gauge in cap																												
Y5 = Back-mounted gauge in cap																												
Electrical																												
ES = Electric switch																												
ES1 = Heavy-duty electric switch with conduit connection																												
ES2 = Electrical Switch with Deutsch Connector																												
BOX 7																												
Outlet Porting																												
Omit = 1½" NPT male																												
D = Diffuser																												
T = 13" Tube Extension																												
G3039 = 1.5" NPT outlet removed																												
<table border="1"> <tr><th>BOX 8</th></tr> <tr><th>Options</th></tr> <tr><td>Omit = None</td></tr> <tr><td>B = Breather</td></tr> <tr><td>M = Mounting Gasket (Buna N)</td></tr> </table>	BOX 8	Options	Omit = None	B = Breather	M = Mounting Gasket (Buna N)																							
BOX 8																												
Options																												
Omit = None																												
B = Breather																												
M = Mounting Gasket (Buna N)																												



Features and Benefits

- Patent Pending In-tank filter design
- Lightweight and as part of a tank optimization package can reduce reservoir size
- Lock & Key Quality Protected, OEM Specific Interfaces available
- Superior de-aeration performance
- 360 degree swivel connection. Lines stay connected during element changeouts
- Anti-Drain Check valve option to keep lines from emptying during element change outs
- 20 ft-lb max loading torque on inlet port

Si Part of Schroeder Industries' Energy Sustainability Initiative

40 gpm
151 L/min
 100 psi
 7 bar

Model No. of filter in photograph is AFT8LKZ10L16N

Flow Rating:	40 gpm (151 L/min)
Max. Operating Pressure:	100 psi (7 bar)
Min. Yield Pressure:	350 psi (24 bar)
Rated Fatigue Pressure:	100 psi (7 bar)
Temp. Range:	-20°F to 225°F (-29°C to 107°C)
Bypass Setting:	Cracking: 30 psi (2 bar) Full Flow: 45 psi (3 bar)
Element Change Clearance:	4LK = 5.28" [134mm] 8LK = 8.62" [219mm] 12LK = 11.96" [304mm] 16LK = 15.30" [389mm]
Element Case:	12 elements

Filter Housing Specifications

Type Fluid	Appropriate Schroeder Media
Petroleum Based Fluids	Z-Media [®] and ASP [®] media (synthetic)
High Water Content	All Z-Media [®] and ASP [®] media (synthetic)
Invert Emulsions	10 and 25 μ Z-Media [®] and 10 μ ASP [®] media (synthetic)
Water Glycols	3, 5, 10 and 25 μ Z-Media [®] and all ASP [®] media (synthetic)
Phosphate Esters	All Z-Media [®] (synthetic) with H (EPR) seal designation and all ASP [®] media (synthetic)

Fluid Compatibility

Accessories For Tank-Mounted Filters

- IRF
- TF1
- KF3
- KL3
- LF1
- MLF1
- RLD
- GRTB
- MTA
- MTB
- ZT
- AFT**
- KFT
- RT
- RTI
- LRT
- ART
- BRT
- TRT
- BFT
- QT
- KTK
- LTK
- MRT
- PAF1
- MAF1
- MF2

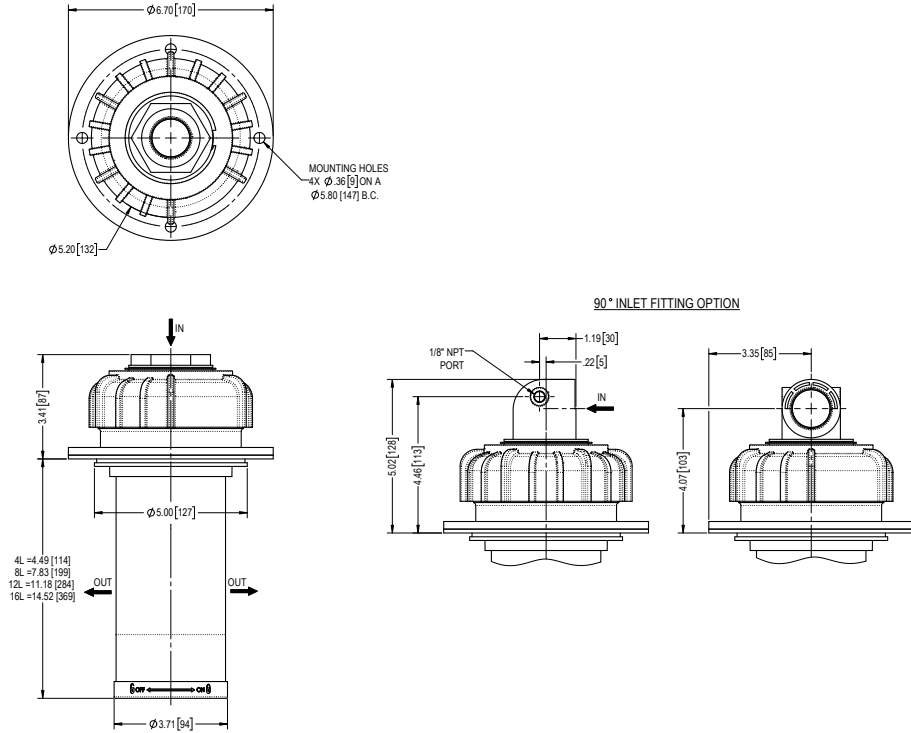

Metric dimensions in (mm).

Element Performance Information & Dirt Holding Capacity

Element	Filtration Ratio Per ISO 4572/NFPA T3.10.8.8 Using automated particle counter (APC) calibrated per ISO 4402			Filtration Ratio wrt ISO 16889 Using APC calibrated per ISO 11171	
	$\beta_x \geq 75$	$\beta_x \geq 100$	$\beta_x \geq 200$	$\beta_x(c) \geq 200$	$\beta_x(c) \geq 1000$
4LKZ3, 8LKZ3 12LKZ3, 16LKZ3	<1.0	<1.0	<2.0	<4.0	4.8
4LKZ5, 8LKZ5 12LKZ5, 16LKZ5	2.5	3.0	4.0	4.8	6.3
4LKZ10, 8LKZ10 12LKZ10, 16LKZ10	7.4	8.2	4.0	8.0	10.0
4LKZ25, 8LKZ25 12LKZ25, 16LKZ25	18.0	20.0	22.5	19.0	24.0

Element	DHC (gm)	Element	DHC (gm)	Element	DHC (gm)	Element	DHC (gm)
4LKZ3	8	8LKZ3	16	12LKZ3	23	16LKZ3	30
4LKZ5	9	8LKZ5	18	12LKZ5	26	16LKZ5	33
4LKZ10	11	8LKZ10	22	12LKZ10	32	16LKZ10	41
4LKZ25	18	8LKZ25	36	12LKZ25	52	16LKZ25	69

Element Burst Pressure: 86 psi (6 bar)

Flow Direction: Inside Out

Element Nominal Dimensions: 4LKZ: 3.71" (94.23 mm) O.D. x 4.49" (114.05 mm) long
 8LKZ: 3.71" (94.23 mm) O.D. x 7.84" (199.14 mm) long
 12LKZ: 3.71" (94.23 mm) O.D. x 11.18" (283.97 mm) long
 16LKZ: 3.71" (94.23 mm) O.D. x 14.52" (368.81 mm) long

$\Delta P_{\text{housing}}$

AFT $\Delta P_{\text{housing}}$ for fluids with sp gr (specific gravity) = 0.86:

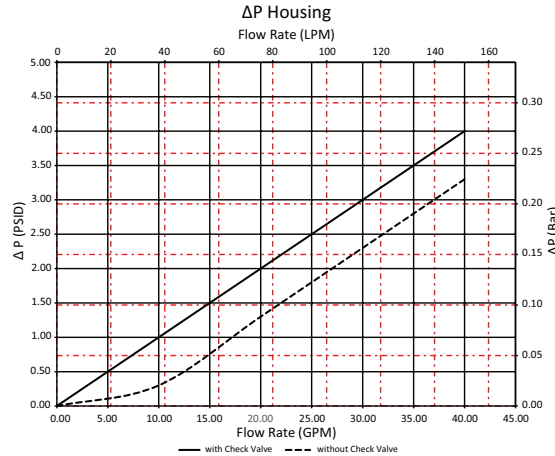

Pressure Drop Information Based on Flow Rate and Viscosity

$\Delta P_{\text{element}}$

4LKZ

Element Pressure Drop versus Flow Rate at 32 cSt (150 SUS)

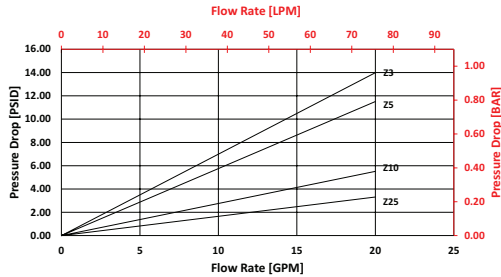

8LKZ

Element Pressure Drop versus Flow Rate at 32 cSt (150 SUS)

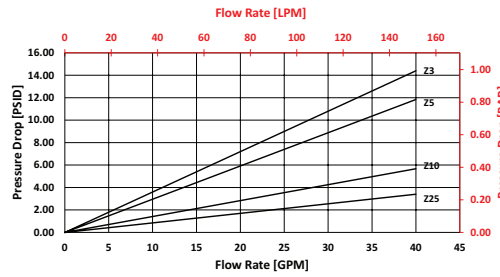

12LKZ

Element Pressure Drop versus Flow Rate at 32 cSt (150 SUS)

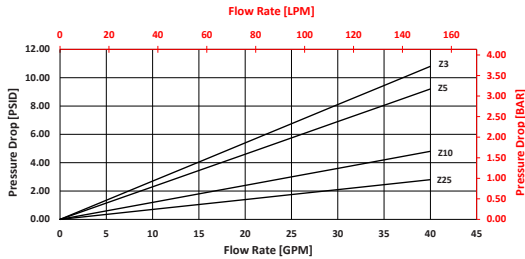

16LKZ

Element Pressure Drop versus Flow Rate at 32 cSt (150 SUS)

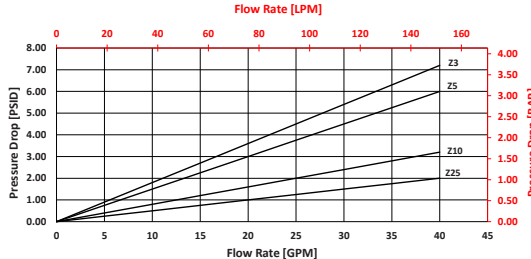

Note: Additional Pressured Drop information available upon request

$$\Delta P_{\text{filter}} = \Delta P_{\text{housing}} + (\Delta P_{\text{element}} * V_f)$$

Exercise:

Determine ΔP_{filter} at 10 gpm (37.9 L/min) for AFT8LKZ10L16Y2 using 160 SUS (34 cSt) fluid.

Use the housing pressure curve to determine $\Delta P_{\text{housing}}$ at 10 gpm. In this case, $\Delta P_{\text{housing}}$ is 1.5 psi (.10 bar) on the graph for the AFT housing.

Use the element pressure curve to determine $\Delta P_{\text{element}}$ at 10 gpm. In this case, $\Delta P_{\text{element}}$ is 1.4 psi (.10 bar) according to the graph for the 8LKZ10 element.

Because the viscosity in this sample is 160 SUS (34 cSt), we determine the Viscosity Factor (V_f) by dividing the Operating Fluid Viscosity with the Standard Viscosity of 150 SUS (32 cSt). To best determine your Operating Fluid Viscosity, please reference the chart in Appendix D.

Finally, the overall filter pressure differential, ΔP_{filter} , is calculated by adding $\Delta P_{\text{housing}}$ with the true element pressure differential, $(\Delta P_{\text{element}} * V_f)$. The $\Delta P_{\text{element}}$ from the graph has to be multiplied by the viscosity factor to get the true pressure differential across the element.

Solution:

$$\Delta P_{\text{housing}} = 1.5 \text{ psi } [.10 \text{ bar}] \mid \Delta P_{\text{element}} = 1.4 \text{ psi } [.10 \text{ bar}]$$

$$V_f = 160 \text{ SUS (34 cSt)} / 150 \text{ SUS (32 cSt)} = 1.1$$

$$\Delta P_{\text{filter}} = 1.5 \text{ psi} + (1.4 \text{ psi} * 1.1) = 3.0 \text{ psi}$$

OR

$$\Delta P_{\text{filter}} = .10 \text{ bar} + (.10 \text{ bar} * 1.1) = .21 \text{ bar}$$

IRF

TF1

KF3

KL3

LF1

MLF1

RLD

GRTB

MTA

MTB

ZT

AFT

KFT

RT

RTI

LRT

ART

BRT

TRT

BFT

QT

KTK

LTK

MRT

Accessories For Tank-Mounted Filters

PAF1

MAF1

MF2

Filter Model Number Selection

How to Build a Valid Model Number for a Schroeder AFT:

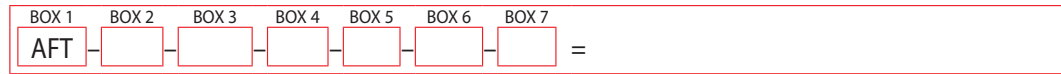

Example: NOTE: One option per box

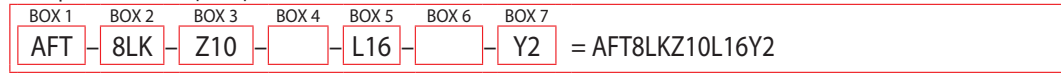

BOX 1	BOX 2	BOX 3	BOX 4
Filter Series	Element	Media	Seal
Air Fusion Technology Filter AFT	4LK = 4" Element 8LK = 8" Element 12LK = 12" Element 16LK = 16" Element	Z3 = 3 micron Z media Z5 = 5 micron Z media Z10 = 10 micron Z media Z25 = 25 micron Z media	Omit = Buna V = Viton H = EPR
BOX 5	BOX 6	BOX 7	
Porting	Bypass	Check Valve	
S12 = SAE 12 S16 = SAE 16 L12 = 90 Deg SAE 12 L16 = 90 Deg SAE 16 HB16 = 1" Hose Barb	25 = 25 psi Omit = 30 psi 40 = 40 psi	Omit = Check Valve N = No Check Valve	
	BOX 8		
	Gauge Port Option (Elbow Only)		
	N = Plugged Y2 = Tricolor visual indicator (Back Mounted) Y2C = Tricolor visual indicator (Bottom Mounted) ES = Electric Switch ES1 = Heavy Duty Electric Switch ES2 = Electrical Switch with Deutsch Connector		

NOTES:

Box 2. Replacement element part numbers are a combination of Boxes 2, 3 and 4. Example: 8LKZ25V

Box 4. Viton® is a registered trademark of DuPont Dow Elastomers.

Box 7. Check valve prevents hydraulic oil to spill when changing out the element and it is recommended. Not including could reduce differential pressure slightly but risks a greater hydraulic oil spill on element change out.

Air Fusion Technology (Fixed Head)

AFTF



Features and Benefits

- Patent Pending In-tank filter design
- Lightweight and as part of a tank optimization package can reduce reservoir size
- Lock & Key Quality Protected, OEM Specific Interfaces available
- Superior de-aeration performance
- Fixed head connection. Lines stay connected during element changeouts

Si Part of Schroeder Industries' Energy Sustainability Initiative

40 gpm
151 L/min
 100 psi
 7 bar

IRF
 TF1
 KF3
 KL3
 LF1
 MLF1
 RLD
 GRTB
 MTA
 MTB
 ZT
 AFT
AFTF

KFT
 RT
 RTI
 LRT
 ART
 BRT
 TRT
 BFT
 QT
 KTK
 LTK
 MRT

Flow Rating:	40 gpm (151 L/min)
Max. Operating Pressure:	100 psi (7 bar)
Min. Yield Pressure:	350 psi (24 bar)
Rated Fatigue Pressure:	100 psi (7 bar)
Temp. Range:	-20°F to 225°F (-29°C to 107°C)
Bypass Setting:	Cracking: 30 psi (2 bar) Full Flow: 45 psi (3 bar)
Element Change Clearance:	4LK = 5.28" [134mm] 8LK = 8.62" [219mm] 12LK = 11.96" [304mm] 16LK = 15.30" [389mm]
Element Case:	12 elements

Filter Housing Specifications

Type Fluid	Appropriate Schroeder Media
Petroleum Based Fluids	Z-Media [®] and ASP [®] media (synthetic)
High Water Content	All Z-Media [®] and ASP [®] media (synthetic)
Invert Emulsions	10 and 25 μ Z-Media [®] and 10 μ ASP [®] media (synthetic)
Water Glycols	3, 5, 10 and 25 μ Z-Media [®] and all ASP [®] media (synthetic)
Phosphate Esters	All Z-Media [®] (synthetic) with H (EPR) seal designation and all ASP [®] media (synthetic)

Fluid Compatibility

Accessories For Tank-Mounted Filters

PAF1
 MAF1
 MF2

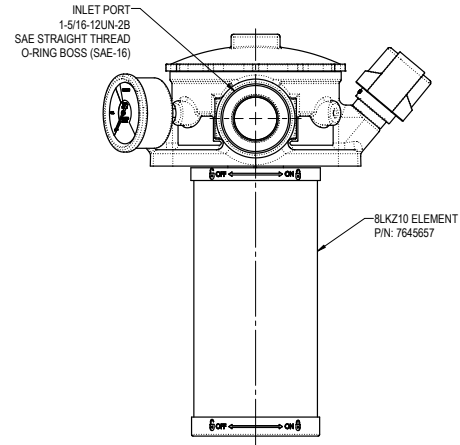
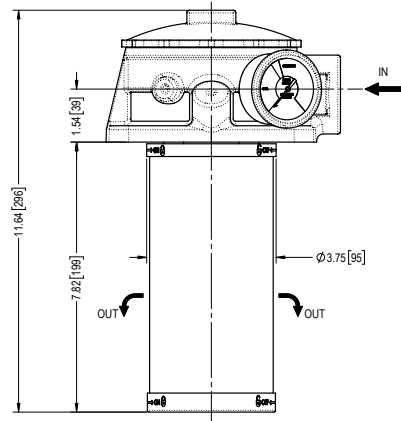
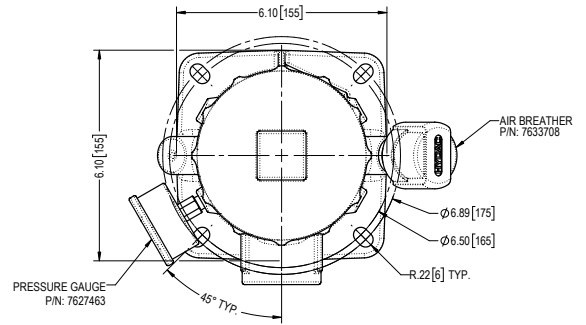

Metric dimensions in (mm).

Element Performance Information & Dirt Holding Capacity

Element	Filtration Ratio Per ISO 4572/NFPA T3.10.8.8 Using automated particle counter (APC) calibrated per ISO 4402			Filtration Ratio wrt ISO 16889 Using APC calibrated per ISO 11171	
	$\beta_x \geq 75$	$\beta_x \geq 100$	$\beta_x \geq 200$	$\beta_x(c) \geq 200$	$\beta_x(c) \geq 1000$
4LKZ3, 8LKZ3 12LKZ3, 16LKZ3	<1.0	<1.0	<2.0	<4.0	4.8
4LKZ5, 8LKZ5 12LKZ5, 16LKZ5	2.5	3.0	4.0	4.8	6.3
4LKZ10, 8LKZ10 12LKZ10, 16LKZ10	7.4	8.2	4.0	8.0	10.0
4LKZ25, 8LKZ25 12LKZ25, 16LKZ25	18.0	20.0	22.5	19.0	24.0

Element	DHC (gm)	Element	DHC (gm)	Element	DHC (gm)	Element	DHC (gm)
4LKZ3	8	8LKZ3	16	12LKZ3	23	16LKZ3	30
4LKZ5	9	8LKZ5	18	12LKZ5	26	16LKZ5	33
4LKZ10	11	8LKZ10	22	12LKZ10	32	16LKZ10	41
4LKZ25	18	8LKZ25	36	12LKZ25	52	16LKZ25	69

Element Burst Pressure: 86 psi (6 bar)

Flow Direction: Inside Out

Element Nominal Dimensions: 4LKZ: 3.71" (94.23 mm) O.D. x 4.49" (114.05 mm) long
 8LKZ: 3.71" (94.23 mm) O.D. x 7.84" (199.14 mm) long
 12LKZ: 3.71" (94.23 mm) O.D. x 11.18" (283.97 mm) long
 16LKZ: 3.71" (94.23 mm) O.D. x 14.52" (368.81 mm) long

$\Delta P_{\text{housing}}$

AFT $\Delta P_{\text{housing}}$ for fluids with sp gr (specific gravity) = 0.86:

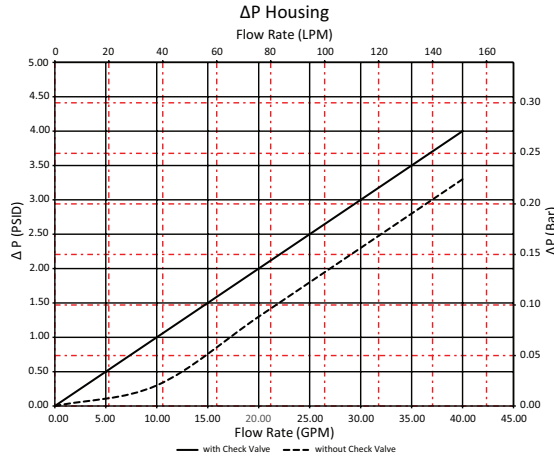

Pressure Drop Information Based on Flow Rate and Viscosity

$\Delta P_{\text{element}}$

4LKZ

Element Pressure Drop versus Flow Rate at 32 cSt (150 SUS)

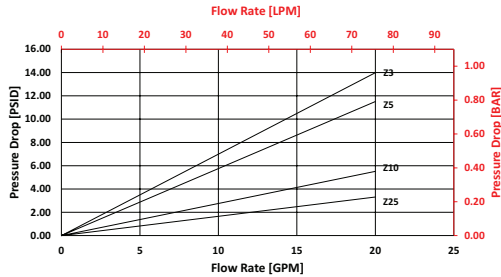

8LKZ

Element Pressure Drop versus Flow Rate at 32 cSt (150 SUS)

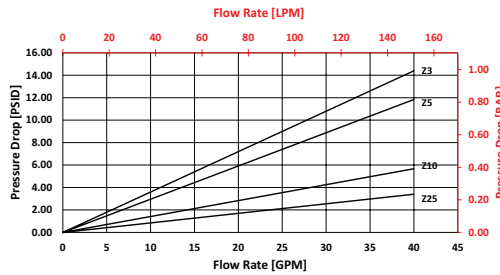

12LKZ

Element Pressure Drop versus Flow Rate at 32 cSt (150 SUS)

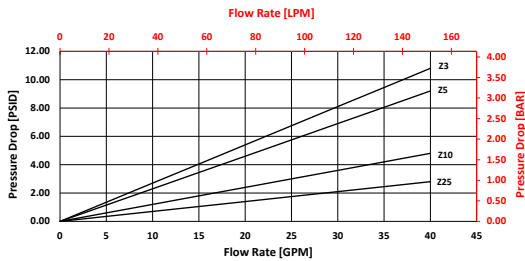

16LKZ

Element Pressure Drop versus Flow Rate at 32 cSt (150 SUS)

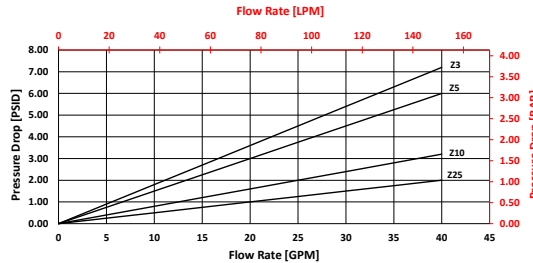

Note: Additional Pressured Drop information available upon request

$$\Delta P_{\text{filter}} = \Delta P_{\text{housing}} + (\Delta P_{\text{element}} * V_f)$$

Exercise:

Determine ΔP_{filter} at 10 gpm (37.9 L/min) for AFT8LKZ10L16Y2 using 160 SUS (34 cSt) fluid.

Use the housing pressure curve to determine $\Delta P_{\text{housing}}$ at 10 gpm. In this case, $\Delta P_{\text{housing}}$ is 1.5 psi (.10 bar) on the graph for the AFT housing.

Use the element pressure curve to determine $\Delta P_{\text{element}}$ at 10 gpm. In this case, $\Delta P_{\text{element}}$ is 1.4 psi (.10 bar) according to the graph for the 8LKZ10 element.

Because the viscosity in this sample is 160 SUS (34 cSt), we determine the Viscosity Factor (V_f) by dividing the Operating Fluid Viscosity with the Standard Viscosity of 150 SUS (32 cSt). To best determine your Operating Fluid Viscosity, please reference the chart in Appendix D.

Finally, the overall filter pressure differential, ΔP_{filter} , is calculated by adding $\Delta P_{\text{housing}}$ with the true element pressure differential, ($\Delta P_{\text{element}} * V_f$). The $\Delta P_{\text{element}}$ from the graph has to be multiplied by the viscosity factor to get the true pressure differential across the element.

Solution:

$$\Delta P_{\text{housing}} = 1.5 \text{ psi } [.10 \text{ bar}] \quad | \quad \Delta P_{\text{element}} = 1.4 \text{ psi } [.10 \text{ bar}]$$

$$V_f = 160 \text{ SUS (34 cSt)} / 150 \text{ SUS (32 cSt)} = 1.1$$

$$\Delta P_{\text{filter}} = 1.5 \text{ psi} + (1.4 \text{ psi} * 1.1) = 3.0 \text{ psi}$$

OR

$$\Delta P_{\text{filter}} = .10 \text{ bar} + (.10 \text{ bar} * 1.1) = .21 \text{ bar}$$

Filter Model Number Selection

How to Build a Valid Model Number for a Schroeder AFTF:

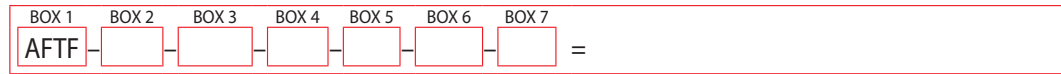

Example: NOTE: One option per box

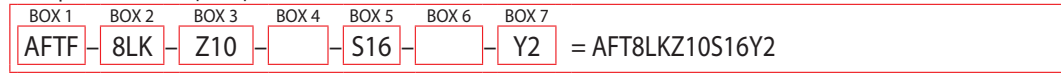

BOX 1	BOX 2	BOX 3	BOX 4
Filter Series	Element	Media	Seal
AFTF Air Fusion Technology Fixed Head Filter	4LK = 4" Element 8LK = 8" Element 12LK = 12" Element 16LK = 16" Element	Z3 = 3 micron Z media Z5 = 5 micron Z media Z10 = 10 micron Z media Z25 = 25 micron Z media	Omit = Buna V = Viton H = EPR
BOX 5	BOX 6	BOX 7	
Porting	Bypass	Gauge Port Option (Elbow Only)	
S16 = SAE 16 S20 = SAE 20 S24 = SAE 24	25 = 25 psi Omit = 30 psi 40 = 40 psi	N = Plugged Y2 = Tricolor visual indicator (Back Mounted) B = Breather ES = Electric Switch ES1 = Heavy Duty Electric Switch ES2 = Electrical Switch with Deutsch Connector	

NOTES:

Box 2. Replacement element part numbers are a combination of Boxes 2, 3 and 4.
Example: 8LKZ25V

Box 4. Viton® is a registered trademark of DuPont Dow Elastomers. All elements for this filter are supplied with Viton® seals.



Model No. of filter in photograph is GPT15DCLKZ25S24S24

Features and Benefits

- Filter bypass in cap vs base, cleaner cold start
- Patent Pending In-Tank Design
- Lock & Key Quality Protected

Filter Housing Specifications

Flow Rating:	Up to 175 GPM (662 L/min) FOR 150 SUS (32 cSt) Fluids
Max. Operating Pressure:	150 PSI (10.3 bar)
Min. Yield Pressure:	Consult Factory
Rated Fatigue Pressure:	89 psi (6 bar)
Temp. Range:	-20 F to 225 F (-29 C to 107 C)
Bypass Setting:	Cracking: 35 PSI (2.4 bar)
Ported Head and Cap:	Die Cast Aluminum
Weight:	7 LBS. (3.18 kg)
Element Change Clearance:	20.0" (508 mm)

Fluid Compatibility

Type Fluid:	Appropriate Schroeder Media
High Water Content:	All Z-Media (synthetic)
Invert Emulsions:	10 and 25 micron Z-Media (synthetic)
Water Glycols:	3, 5, 10, and 25 micron Z-Media (synthetic)
Phosphate Esters:	All Z-Media (synthetic) with H (EPR) seal designation

Element Performance Information

Element	Filtration Ratio Per ISO 4572/NFPA T3.10.8.8 Using automated particle counter (APC) calibrated per ISO 4402	Filtration Ratio per ISO 16889 Using APC calibrated per ISO 11171
	$\beta_x \geq 75$	$\beta_x(c) \geq 1000$
15TLKZ3	<4.0	4.8
15TLKZ5	4.8	6.3
15TLKZ10	8.0	10.0
15TLKZ25	19.0	24.0

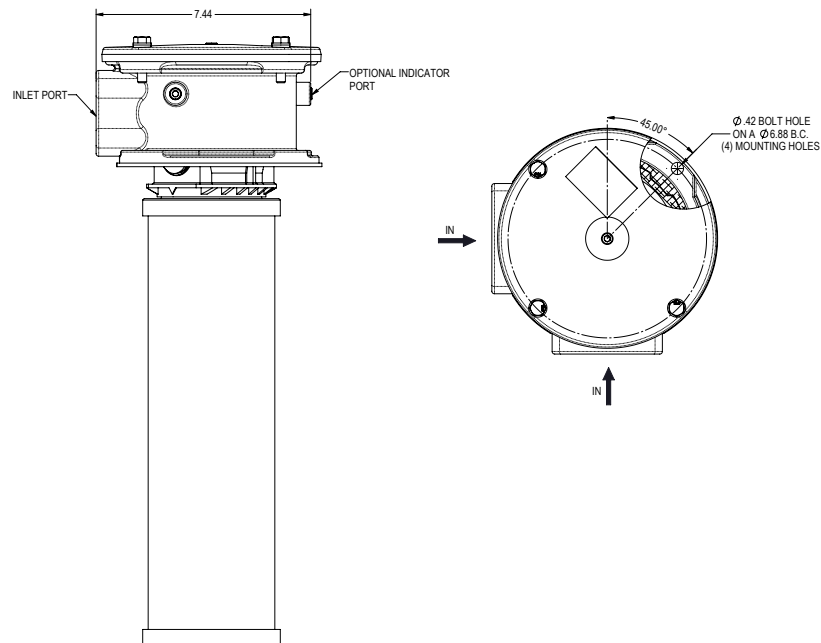
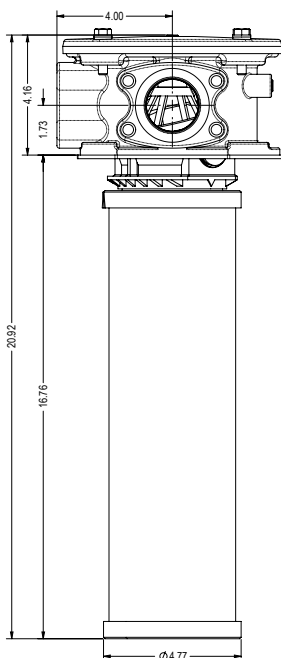

Tank-Mounted Filter

GPT

Pressure Drop Information Based on Flow Rate & Viscosity

Element	ΔP	Housing	ΔP
15TLKZ3	0.09	0 GPM	0
15TLKZ5	0.08	50 GPM	0.5
15TLKZ10	0.06	100 GPM	1
15TLKZ25	0.05	150 GPM	1.5
		200 GPM	2.0

Element Dirt Holding Capacity

Element	DHC (gm)
15TLKZ3	234
15TLKZ5	259
15TLKZ10	231
15TLKZ25	312

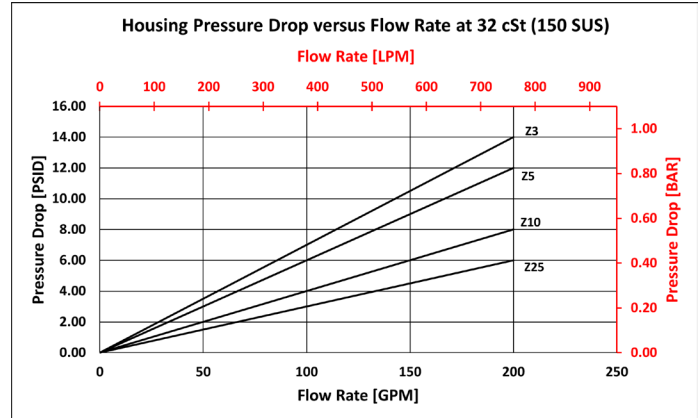
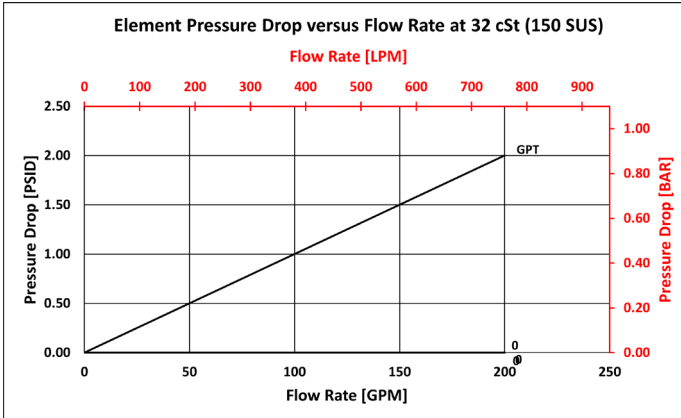

How to Build a Valid Model Number for a Schroeder GPT:

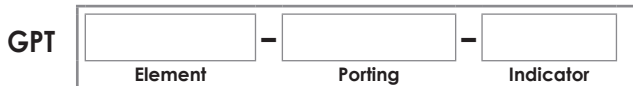

Element	Element	Media	Micron Rating	Seals
Note: Element code can also be used to build a replacement element.	15DCLK = 15" Element	Z = Excellence Z-Media (synthetic) Note: Other media is available upon request.	3 = 3 Micron 5 = 5 Micron 10 = 10 Micron 25 = 25 Micron	Omit = Buna V = Viton H = EPR
Porting	Porting 1	Porting 2	Bypass	
	S24 = SAE-24 P24 = 1 1/2" NPT F32 = 2" SAE Code 61 Flange	S24 = SAE-24 P24 = 1 1/2" NPT F32 = 2" SAE Code 61 Flange	Omit = 35 PSI Cracking	
Indicator				
Y2 = Tricolor Visual Indicator (Back Mounted) Y2C = Tricolor Visual Indicator (Bottom Mounted) ES = Electric Switch ES1 = Heavy Duty Electric Switch ES2 = Electric Switch with Deutsch Connector				

The 15DCLK element assembly is made up of the GPT diverter cap and the 15TLK element.

A list of model code pairings is shown below:

15DCLKZ10,ELEMENT = DIVERTER, ASSY, GPT, BUNA + 15TLKZ10, ELEMENT
15DCLKZ25,ELEMENT = DIVERTER, ASSY, GPT, BUNA + 15TLKZ25, ELEMENT
15DCLKZ3,ELEMENT = DIVERTER, ASSY, GPT, BUNA + 15TLKZ3, ELEMENT
15DCLKZ5,ELEMENT = DIVERTER, ASSY, GPT, BUNA + 15TLKZ5, ELEMENT

15DCLKZ10 GPT Diverter 15TLKZ10

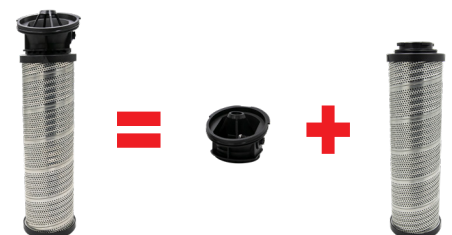

Tank-Mounted Filter

KFT



Features and Benefits

- Low pressure tank-mounted filter
- Meets HF4 automotive standard
- Multiple inlet/outlet porting options
- Top, side or bottom mounting
- Optional check valve prevents reservoir siphoning
- Can also be used in return line application (contact factory)
- Double stacking of K-size element can be replaced by single KK element
- Allows consolidation of inventoried replacement elements by using K-size elements
- Also available with DirtCatcher® elements (KD and KKD)

100 gpm
380 L/min
100 psi
7 bar

Model No. of filter in photograph is KFT1K10P24P24NB

Flow Rating:	Up to 100 gpm (380 L/min) for 150 SUS (32 cSt) fluids
Max. Operating Pressure:	100 psi (7 bar)
Min. Yield Pressure:	400 psi (28 bar), per NFPA T2.6.1
Rated Fatigue Pressure:	Contact Factory
Temp. Range:	-20°F to 225°F (-29°C to 107°C)
Bypass Setting:	Cracking: 25 psi (1.7 bar) Full Flow: 48 psi (3.3 bar)
Porting Head:	Steel
Porting Cap:	Die Cast Aluminum (standard); Steel (optional)
Element Case:	Steel
Weight of KFT-1K:	10.0 lbs. (4.5 kg)
Weight of KFT-2K:	13.6 lbs. (6.2 kg)
Element Change Clearance:	8.0" (205 mm) for 1K; 17.50" (445 mm) for KK; 26.5" (673 mm) for 27K

Filter Housing Specifications

Type Fluid	Appropriate Schroeder Media
Petroleum Based Fluids	All E media (cellulose), Z-Media® and ASP® media (synthetic)
High Water Content	All Z-Media and ASP® media (synthetic)
Invert Emulsions	10 and 25 µ Z-Media® (synthetic), 10 µ ASP® media (synthetic)
Water Glycols	3, 5, 10 and 25 µ Z-Media® (synthetic), 3, 5 and 10 µ ASP® media (synthetic)
Phosphate Esters	All Z-Media® (synthetic) with H (EPR) seal designation, ASP® media (synthetic) and 3 and 10 µ E media (cellulose) with H (EPR) seal designation
Skydrol®	3, 5, 10 and 25 µ Z-Media® (synthetic) with H.5 seal designation, ASP® media (synthetic) (EPR seals and stainless steel wire mesh in element, and light oil coating on housing exterior)

Fluid Compatibility

Accessories For Tank-Mounted Filters

- IRF
- TF1
- KF3
- KL3
- LF1
- MLF1
- RLD
- GRTB
- MTA
- MTB
- ZT
- AFT
- KFT**
- RT
- RTI
- LRT
- ART
- BRT
- TRT
- BFT
- QT
- KTK
- LTK
- MRT
- PAF1
- MAF1
- MF2

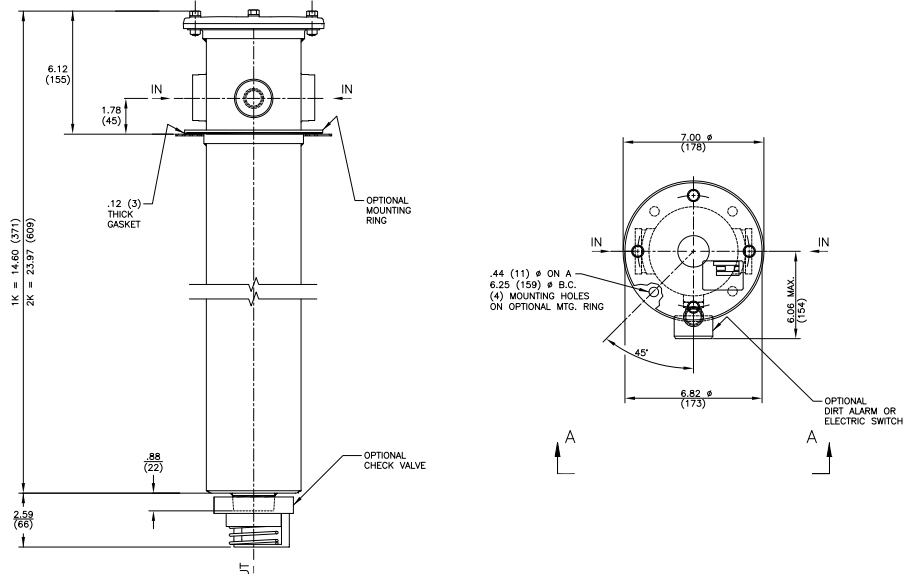

Metric dimensions in ().

Element Performance Information & Dirt Holding Capacity

Element	Filtration Ratio Per ISO 4572/NFPA T3.10.8.8 Using automated particle counter (APC) calibrated per ISO 4402			Filtration Ratio per ISO 16889 Using APC calibrated per ISO 11171	
	$\beta_x \geq 75$	$\beta_x \geq 100$	$\beta_x \geq 200$	$\beta_x(c) \geq 200$	$\beta_x(c) \geq 1000$
KZ1/KKZ1	<1.0	<1.0	<1.0	<4.0	4.2
KZ3/KKZ3/KAS3/KKAS3	<1.0	<1.0	<2.0	<4.0	4.8
KZ5/KKZ5/KAS5/KKAS5	2.5	3.0	4.0	4.8	6.3
KZ10/KKZ10/KAS10/KKAS10	7.4	8.2	10.0	8.0	10.0
KZ25/KKZ25	18.0	20.0	22.5	19.0	24.0

Element	DHC (gm)	Element	DHC (gm)	Element	DHC (gm)	Element	DHC (gm)
KZ1	112	KKZ1	224	KDZ1	89	KKDZ1	188
KZ3/KAS3	115	KKZ3/KKAS3	230	KDZ3	71	KKDZ3	150
KZ5/KAS5	119	KKZ5/KKAS5	238	KDZ5	100	KKDZ5	210
KZ10/KAS10	108	KKZ10/KKAS10	216	KDZ10	80	KKDZ10	168
KZ25	93	KKZ25	186	KDZ25	81	KKDZ25	171

Element Collapse Rating: 150 psid (10 bar) for standard elements

Flow Direction: Outside In

Element Nominal Dimensions: K: 3.9" (99 mm) O.D. x 9.0" (230 mm) long
 KK: 3.9" (99 mm) O.D. x 18.0" (460 mm) long

$\Delta P_{\text{housing}}$

KFT $\Delta P_{\text{housing}}$ for fluids with sp gr (specific gravity) = 0.86:

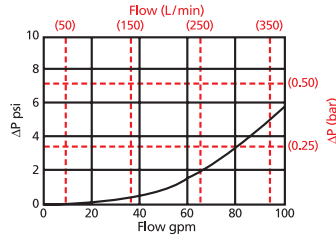

$\Delta P_{\text{element}}$

KZ

Element Pressure Drop versus Flow Rate at 32 cSt (150 SUS)

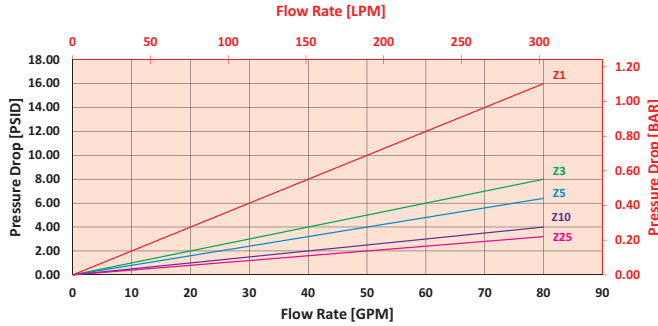

KKZ/2KZ

Element Pressure Drop versus Flow Rate at 32 cSt (150 SUS)

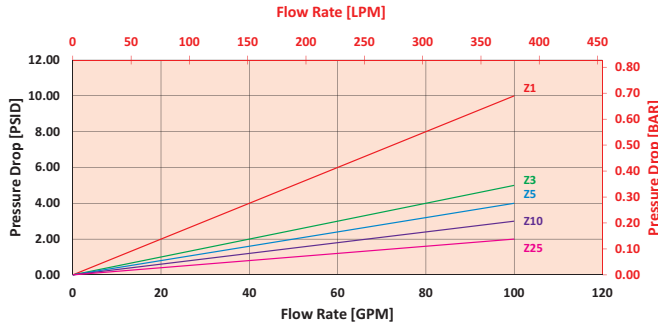

$$\Delta P_{\text{filter}} = \Delta P_{\text{housing}} + (\Delta P_{\text{element}} * V_f)$$

Exercise:

Determine ΔP_{filter} at 80 gpm (303.2 L/min) for KFT1KZ10S24S24NY2G820 using 160 SUS (34 cSt) fluid.

Use the housing pressure curve to determine $\Delta P_{\text{housing}}$ at 80 gpm. In this case, $\Delta P_{\text{housing}}$ is 3.5 psi (.24 bar) on the graph for the KFT housing.

Use the element pressure curve to determine $\Delta P_{\text{element}}$ at 80 gpm. In this case, $\Delta P_{\text{element}}$ is 4 psi (.27 bar) according to the graph for the KZ10 element.

Because the viscosity in this sample is 200 SUS (24 cSt), we determine the Viscosity Factor (V_f) by dividing the Operating Fluid Viscosity with the Standard Viscosity of 150 SUS (32 cSt). To best determine your Operating Fluid Viscosity, please reference the chart in Appendix D.

Finally, the overall filter pressure differential, ΔP_{filter} , is calculated by adding $\Delta P_{\text{housing}}$ with the true element pressure differential, ($\Delta P_{\text{element}} * V_f$). The $\Delta P_{\text{element}}$ from the graph has to be multiplied by the viscosity factor to get the true pressure differential across the element.

Solution:

$\Delta P_{\text{housing}} = 3.5 \text{ psi } [.24 \text{ bar}] \mid \Delta P_{\text{element}} = 4 \text{ psi } [.27 \text{ bar}]$

$V_f = 160 \text{ SUS (34 cSt) } / 150 \text{ SUS (32 cSt)} = 1.1$

$\Delta P_{\text{filter}} = 3.5 \text{ psi } + (4 \text{ psi } * 1.1) = 7.9 \text{ psi}$

OR

$\Delta P_{\text{filter}} = .24 \text{ bar } + (.27 \text{ bar } * 1.1) = .54 \text{ bar}$

Pressure Drop Information Based on Flow Rate and Viscosity

Note:

If your element is not graphed, use the following equation:

$\Delta P_{\text{element}} = \text{Flow Rate} \times \Delta P_f$. Plug this variable into the overall pressure drop equation.

Ele.	ΔP	Ele.	ΔP	Ele.	ΔP
K3	0.25	2K3/ KK3	0.12	3KZ1/ 27KZ1	0.05
K10	0.09	2K10/ KK10	0.05	3KZ3/ 27KZ3	0.03
K25	0.02	2K25/ KK25	0.01	3KZ5/ 27KZ5	0.02
KAS3	0.10	2KAS3/ KKAS3	0.05	3KZ10/ 27KZ10	0.02
KAS5	0.08	2KAS5/ KKAS5	0.04	3KZ25/ 27KZ25	0.01
KAS10	0.05	2KAS10/ KKAS10	0.03	3K3	0.08
KDZ1	0.24	2KDZ1	0.12	3K10	0.03
KDZ3	0.12	2KDZ3	0.06	3K25	0.01
KDZ5	0.10	2KDZ5	0.05	3KAS3/ 27KAS3	0.03
KDZ10	0.06	2KDZ10	0.03	3KAS5/ 27KAS5	0.02
KDZ25	0.04	2KDZ25	0.02	3KAS10/ 27KAS10	0.02

Filter Model Number Selection

How to Build a Valid Model Number for a Schroeder KFT:

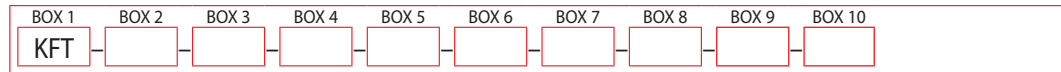

Example: NOTE: One option per box

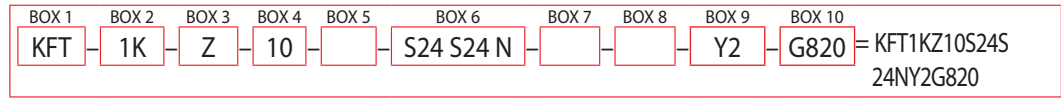

BOX 1	BOX 2	BOX 3	BOX 4
Filter Series	Element Size and Length	Media Type	Element Part Number
KFT	1 K, KK 2 K	Omit = E media (cellulose) Z = Excellement® Z-Media® (synthetic) AS = Anti-Static Pleat Media (synthetic) ZW = Aqua-Excellement™ ZW media DZ = DirtCatcher® with Excellement® Z-Media®	1 = 1 μZ, ZW, and DZ media 3 = 3 μAS, E, Z, ZW, and DZ media 5 = 5 μAS, Z, ZW, and DZ media 10 = 10 μAS, E, M, Z, ZW, and DZ media 25 = 25 μE, M, Z, ZW, and DZ media

BOX 5	BOX 6 Specification of all 4 ports is required				Inlet Porting Location
Seal Material	Inlet Porting				
Omit = Buna N H = EPR H.5 = Skydrol® Compatibility	Port 1 (Standard) N = None	Port 2 (Optional) N = None	Port 3 (Optional) N = None	Port 4 (Optional) N = None	
	P12 = 3/4" NPTF P16 = 1" NPTF P20 = 1 1/4" NPTF P24 = 1 1/2" NPTF P32 = 2" NPTF S8 = SAE-8 S12 = SAE-12 S16 = SAE-16 S20 = SAE-20 S24 = SAE-24	P12 = 3/4" NPTF P16 = 1" NPTF P20 = 1 1/4" NPTF P24 = 1 1/2" NPTF P32 = 2" NPTF S8 = SAE-8 S12 = SAE-12 S16 = SAE-16 S20 = SAE-20 S24 = SAE-24	P8 = 1/2" NPTF P12 = 3/4" NPTF P16 = 1" NPTF P20 = 1 1/4" NPTF P24 = 1 1/2" NPTF P32 = 2" NPTF S8 = SAE-8 S12 = SAE-12 S16 = SAE-16 S20 = SAE-20 S24 = SAE-24	P2 = 1/8" NPTF P8 = 1/2" NPTF P12 = 3/4" NPTF P16 = 1" NPTF P20 = 1 1/4" NPTF P24 = 1 1/2" NPTF P32 = 2" NPTF S8 = SAE-8 S12 = SAE-12 S16 = SAE-16 S20 = SAE-20 S24 = SAE-24	

NOTES:

- Box 2. Number of elements must equal 1 when using KK elements.
- Box 3. Replacement element part numbers are identical to contents of Boxes 2, 3, 4 and 5. K specifies one 9" element; KK specifies one 18" element. Example: KKZ10
- Box 5. H.5 seal designation includes the following: EPR seals, stainless steel wire mesh on elements, and light oil coating on housing exterior. Skydrol® is a registered trademark of Solutia Inc. Viton® is a registered trademark of DuPont Dow Elastomers.
- Box 7. See also "Accessories for Tank-Mounted Filters," page 307.
- Box 9. YC2 and Y5 are not available with the G820.

BOX 7	BOX 8	BOX 9
Outlet Porting Options	Optional Mounting Flange	Dirt Alarm® Options
Omit = 1 1/2" NPT male C = Check valve D = Diffuser CD = Check valve & diffuser T = 13" Tube extension A = Non-threaded outlet	Omit = None B = Flange with 4 holes BW = Flange with no holes	Omit = None Y2 = Back-mounted tri-color gauge (located in Port 4) Visual Y2C = Bottom-mounted tri-color gauge in cap Y5 = Back-mounted gauge in cap ES = Electric switch (located in port 4) Electrical ES1 = Heavy-duty electric switch with conduit connector (located in port 4) ES2 = Electrical Switch with Deutsch Connector
BOX 10		
Additional Options		
Omit = None G2293 = Cork gasket G820 = Steel cap		

Tank-Mounted Filter

RT



Features and Benefits

- Low pressure tank-mounted filter with up to 3 inlet ports
- Meets HF4 automotive standard
- Top, side or bottom mounting
- Optional check valve prevents reservoir siphoning
- RTW model allows filter to be welded to tank, instead of being bolted
- Double and triple stacking of K-size element can be replaced by single KK or 27K-size element
- Also available with new DirtCatcher® elements (KDZ and KKDZ)
- Various Dirt Alarm® options
- Allows consolidation of inventoried replacement elements by using K-size elements
- Available with quality-protected GeoSeal® Elements (GRT)
- Same day shipment model available

100 gpm
380 L/min
100 psi
7 bar

Model No. of filter in photograph is RT1K10S24NP16Y2.

Flow Rating:	Up to 100 gpm (380 L/min) for 150 SUS (32 cSt) fluids
Max. Operating Pressure:	100 psi (7 bar)
Min. Yield Pressure:	400 psi (28 bar), per NFPA T2.6.1
Rated Fatigue Pressure:	90 psi (6 bar), per NFPA T2.6.1-2005
Temp. Range:	-20°F to 225°F (-29°C to 107°C)
Bypass Setting:	Cracking: 25 psi (1.7 bar) Full Flow: 48 psi (3.3 bar)
Porting Head & Cap:	Die Cast Aluminum
Element Case:	Steel
Weight of RT-1K:	11.4 lbs. (5.2 kg)
Weight of RT-2K:	14.5 lbs. (6.6 kg)
Element Change Clearance:	8.0" (205 mm) for 1K; 17.50" (445 mm) for KK; 26.5" (673 mm) for 27K

Filter Housing Specifications

Type Fluid	Appropriate Schroeder Media
Petroleum Based Fluids	All E media (cellulose), Z-Media® and ASP® media (synthetic)
High Water Content	All Z-Media® and all ASP® media (synthetic)
Invert Emulsions	10 and 25 µ Z-Media® and 10 µ ASP® media (synthetic)
Water Glycols	3, 5, 10 and 25 µ Z-Media® and all ASP® media (synthetic)
Phosphate Esters	All Z-Media® (synthetic) with H (EPR) seal designation and 3 and 10 µ E media (cellulose) with H (EPR) seal designation and all ASP® Media (synthetic)
Skydrol®	3, 5, 10 and 25 µ Z-Media® (synthetic) with H.5 seal designation (EPR seals and stainless steel wire mesh in element, and light oil coating on housing exterior) and all ASP® media (synthetic)

Fluid Compatibility

Accessories For Tank-Mounted Filters

IRF

TF1

KF3

KL3

LF1

MLF1

RLD

GRTB

MTA

MTB

ZT

AFT

KFT

RT

RTI

LRT

ART

BRT

TRT

BFT

QT

KTK

LTK

MRT

PAF1

MAF1

MF2

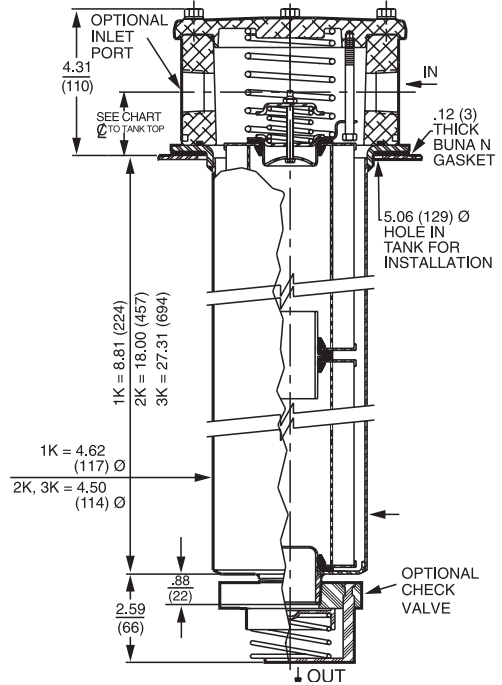
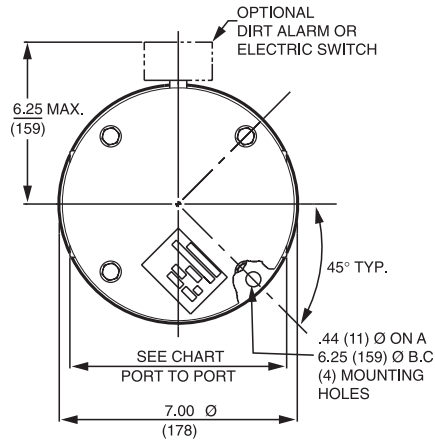

	1½" Ports 4-Bolt Flange Only	2" Ports	All Other Porting
Port to Port	7.12"	7.56" (P, S, B) 7.38" (F)	6.38"
☐ to Casting Base	1.75"	1.81"	1.56"
☐ to Tank Top	2.06"	2.12"	1.88"

Optional mounting rings available for tank welding. See page 307, reference part numbers A-LFT-813 and A-LFT-1448.

Metric dimensions in ().

Element Performance Information & Dirt Holding Capacity

Element	Filtration Ratio Per ISO 4572/NFPA T3.10.8.8 Using automated particle counter (APC) calibrated per ISO 4402			Filtration Ratio per ISO 16889 Using APC calibrated per ISO 11171	
	$\beta_x \geq 75$	$\beta_x \geq 100$	$\beta_x \geq 200$	$\beta_x(c) \geq 200$	$\beta_x(c) \geq 1000$
KZ1/KKZ1/27KZ1	<1.0	<1.0	<1.0	<4.0	4.2
KZ3/KKZ3/27KZ3	<1.0	<1.0	<2.0	<4.0	4.8
KZ5/KKZ5/27KZ5	2.5	3.0	4.0	4.8	6.3
KZ10/KKZ10/27KZ10	7.4	8.2	10.0	8.0	10.0
KZ25/KKZ25/27KZ25	18.0	20.0	22.5	19.0	24.0
KZW1	N/A	N/A	N/A	<4.0	<4.0
KZW3/KKZW3	N/A	N/A	N/A	4.0	4.8
KZW5/KKZW5	N/A	N/A	N/A	5.1	6.4
KZW10/KKZW10	N/A	N/A	N/A	6.9	8.6
KZW25/KKZW25	N/A	N/A	N/A	15.4	18.5

Element	DHC (gm)	Element	DHC (gm)	Element	DHC (gm)	Element	DHC (gm)	Element	DHC (gm)	Element	DHC (gm)
KZ1	112	KKZ1	224	27KZ1	336	KDZ1	89	KKDZ1	188	KZW1	61
KZ3	115	KKZ3	230	27KZ3	345	KDZ3	71	KKDZ3	150	KZW3	64
KZ5	119	KKZ5	238	27KZ5	357	KDZ5	100	KKDZ5	210	KZW5	63
KZ10	108	KKZ10	216	27KZ10	324	KDZ10	80	KKDZ10	168	KZW10	57
KZ25	93	KKZ25	186	27KZ25	279	KDZ25	81	KKDZ25	171	KZW25	79
										KKZW3	128
										KKZW5	126
										KKZW10	114
										KKZW25	158

Element Collapse Rating: 150 psid (10 bar) for standard elements

Flow Direction: Outside In See RTI, page 275 for inside out flow version.

Element Nominal Dimensions: K: 3.9" (99 mm) O.D. x 9.0" (230 mm) long
 KK: 3.9" (99 mm) O.D. x 18.0" (460 mm) long
 27K: 3.9" (99 mm) O.D. x 27.0" (690 mm) long

$\Delta P_{\text{housing}}$

RT $\Delta P_{\text{housing}}$ for fluids with sp gr (specific gravity) = 0.86:

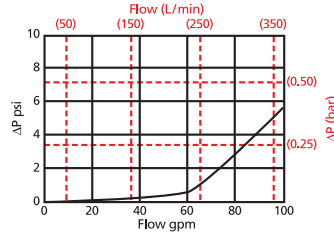

$\Delta P_{\text{element}}$

KZ

Element Pressure Drop versus Flow Rate at 32 cSt (150 SUS)

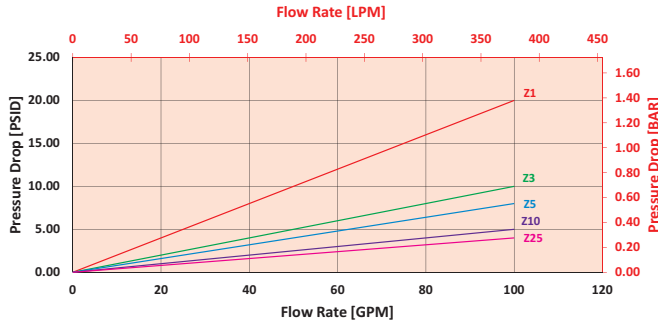

2KZ/KKZ

Element Pressure Drop versus Flow Rate at 32 cSt (150 SUS)

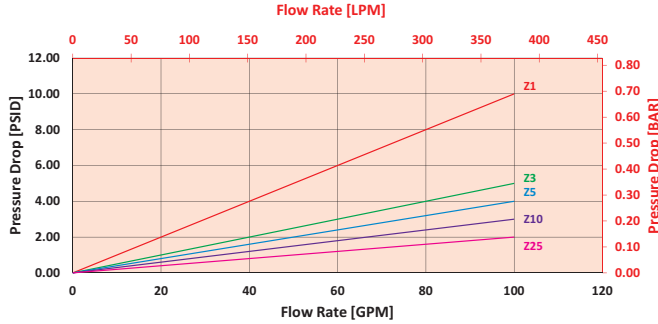

$$\Delta P_{\text{filter}} = \Delta P_{\text{housing}} + (\Delta P_{\text{element}} * V_f)$$

Exercise:

Determine ΔP_{filter} at 80 gpm (303.2 L/min) for RT1KZ10S24S24NY2 using 160 SUS (34 cSt) fluid.

Use the housing pressure curve to determine $\Delta P_{\text{housing}}$ at 80 gpm. In this case, $\Delta P_{\text{housing}}$ is 3 psi (.21 bar) on the graph for the RT housing.

Use the element pressure curve to determine $\Delta P_{\text{element}}$ at 80 gpm. In this case, $\Delta P_{\text{element}}$ is 4 psi (.27 bar) according to the graph for the KZ10 element.

Because the viscosity in this sample is 160 SUS (34 cSt), we determine the Viscosity Factor (V_f) by dividing the Operating Fluid Viscosity with the Standard Viscosity of 150 SUS (32 cSt). To best determine your Operating Fluid Viscosity, please reference the chart in Appendix D.

Finally, the overall filter pressure differential, ΔP_{filter} , is calculated by adding $\Delta P_{\text{housing}}$ with the true element pressure differential, $(\Delta P_{\text{element}} * V_f)$. The $\Delta P_{\text{element}}$ from the graph has to be multiplied by the viscosity factor to get the true pressure differential across the element.

Solution:

$\Delta P_{\text{housing}} = 3 \text{ psi } [.21 \text{ bar}] \mid \Delta P_{\text{element}} = 4 \text{ psi } [.27 \text{ bar}]$

$V_f = 160 \text{ SUS } (34 \text{ cSt}) / 150 \text{ SUS } (32 \text{ cSt}) = 1.1$

$\Delta P_{\text{filter}} = 3 \text{ psi } + (4 \text{ psi } * 1.1) = 7.4 \text{ psi}$

OR

$\Delta P_{\text{filter}} = .21 \text{ bar } + (.27 \text{ bar } * 1.1) = .51 \text{ bar}$

Pressure Drop Information Based on Flow Rate and Viscosity

Note:
If your element is not graphed, use the following equation:
 $\Delta P_{\text{element}} = \text{Flow Rate} \times \Delta P_f$ Plug this variable into the overall pressure drop equation.

Ele.	ΔP	Ele.	ΔP	Ele.	ΔP
K3	0.25	2K3/ KK3	0.12	3KZ1/ 27KZ1	0.05
K10	0.09	2K10/ KK10	0.05	3KZ3/ 27KZ3	0.03
K25	0.02	2K25/ KK25	0.01	3KZ5/ 27KZ5	0.02
KAS3	0.10	2KAS3/ KKAS3	0.05	3KZ10/ 27KZ10	0.02
KAS5	0.08	2KAS5/ KKAS5	0.04	3KZ25/ 27KZ25	0.01
KAS10	0.05	2KAS10/ KKAS10	0.03	3K3	0.08
KDZ1	0.24	2KDZ1	0.12	3K10	0.03
KDZ3	0.12	2KDZ3	0.06	3K25	0.01
KDZ5	0.10	2KDZ5	0.05	3KAS3/ 27KAS3	0.03
KDZ10	0.06	2KDZ10	0.03	3KAS5/ 27KAS5	0.02
KDZ25	0.04	2KDZ25	0.02	3KAS10/ 27KAS10	0.02
KZW1	0.43	2KZW1	-		
KZW3	0.32	2KZW3/ KKZW3	0.16		
KZW5	0.28	2KZW5/ KKZW5	0.14		
KZW10	0.23	2KZW10/ KKZW10	0.12		
KZW25	0.14	2KZW25/ KKZW25	0.07		

Filter Model Number Selection

Highlighted product eligible for **QuickDelivery**

How to Build a Valid Model Number for a Schroeder RT:

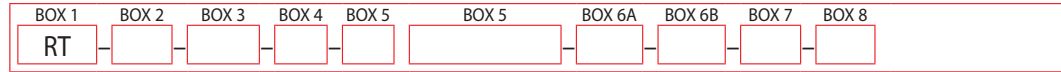

Example: NOTE: Only box 9 may contain more than one option

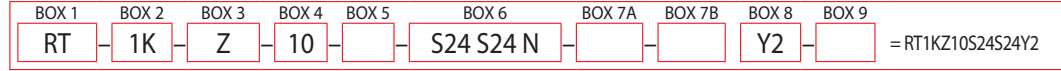

BOX 1	BOX 2	BOX 3	BOX 4
Filter Series	Element Size & Length	Media Type	Element Part Number
RT	1K KK, 27K	Omit = E media (cellulose)	1 = 1 μ Z, ZW, and DZ media
RTW	2K	Z = Excellement® Z-Media® (synthetic)	3 = 3 μ AS, E, Z, ZW, and DZ media
GRT	3K	AS = Anti-Static Pleat Media (synthetic)	5 = 5 μ AS, Z, ZW, and DZ media
	GeoSeal®	ZW = Aqua-Excellement™ ZW media	10 = 10 μ AS, E, M, Z, ZW, and DZ media
	1KBG KKBG, 27KBG	DZ = Dirtcatcher® with Excellement® Z-Media®	25 = 25 μ E, M, Z, ZW, and DZ media
	2KBG	W = W media (water removal)	60 = 60 μ M media
	3KBG	M = M media (reusable metal mesh)	

BOX 5	BOX 6
Seal Material	Inlet Porting Specification of all 3 ports is required
Omit = Buna N	Port A
H = EPR	P16 = 1" NPTF
W = Anodized Aluminum Parts	P20 = 1 1/4" NPTF
H.5 = Skydrol® compatibility	P24 = 1 1/2" NPTF
	P32 = 2" NPTF
	S16 = SAE-16
	S20 = SAE-20
	S24 = SAE-24
	S32 = SAE-32
	F20 = 1 1/4" SAE 4-bolt flange Code 61
	F24 = 1 1/2" SAE 4-bolt flange Code 61
	F32 = 2" SAE 4-bolt flange Code 61
	B24 = ISO 228 G-1 1/2"
	Flange port option only:
	M = Metric SAE 4 bolt flange
	Port B
	N = None
	P16 = 1" NPTF
	P20 = 1 1/4" NPTF
	P24 = 1 1/2" NPTF
	P32 = 2" NPTF
	S16 = SAE-16
	S20 = SAE-20
	S24 = SAE-24
	S32 = SAE-32
	F20 = 1 1/4" SAE 4-bolt flange Code 61
	F24 = 1 1/2" SAE 4-bolt flange Code 61
	F32 = 2" SAE 4-bolt flange Code 61
	B24 = ISO 228 G-1 1/2"
	Port C
	N = None
	P2 = 1/8" NPTF
	P16 = 1" NPTF
	S16 = SAE-16
	Inlet Porting Location

BOX 7A	BOX 7B
Bypass Option	Outlet Porting Options
Omit = 25 psi bypass setting	Omit = 1 1/2" NPT male
RT and RTW models only:	C = Check valve
40 = 40 psi bypass setting	D = Diffuser
50 = 50 psi bypass setting	CD = Check Valve & Diffuser
	T = 13" Tube ext.
	A = Non-thread outlet

BOX 8		
Dirt Alarm® Options		
		Omit = None
	Visual	Y2 = Back-mounted tri-color gauge
Located @ Port D	Electrical	ES = Electric Switch
		ES1 = Electric Switch with 24" wire leads
		ES2 = Electrical Switch with Deutsch Connector
		ES3 = Electric switch with DIN connector
		ES4 = Skydrol Compatible Electric Switch
Located in cap	Visual	Y2C = Bottom-mounted tri-color gauge
		Y5 = Back-mounted gauge in cap
Located @ Port C	Visual	Y2R = Back-mounted gauge mounted on opposite side of standard location
	Electrical	ESR = Electric switch mounted on opposite side of standard location
		ES1R = Heavy-duty electric switch mounted on opposite side of standard location

BOX 9
Add. Options
Omit = None
G2293 = Cork gasket
G547 = Two 1/8" gauge ports
G820 = Stamped cap

- NOTES:
- Box 1. RTW allows filter to be welded to tank instead of bolted.
 - Box 2. Number of elements must equal 1 when using KK or 27K elements.
 - Box 3. Replacement element part numbers are identical to contents of Boxes 2, 3, 4, and 5. Double and triple stacking of K-size elements can be replaced by single KK and 27K elements, respectively. ZW media not available in 27K length.
 - Box 5. For options H, W, and H.5 all aluminum parts are anodized. H.5 seal designation includes the following: EPR seals, stainless steel wire mesh on elements, and light oil coating on housing exterior. Skydrol® is a registered trademark of Solutia Inc.
 - Box 6. If using Port B, Port A & B must always be the same type and size. Example: (A) P20 (B) P20 (C) P16
 - Box 7B. See also "Accessories for Tank-Mounted Filters," page 307.

Tank-Mounted Filter (Inside Out Flow)

RTI



Features and Benefits

- Tank-mounted "Inside Out" flow filter
- Up to 3 inlet ports available
- Offered in pipe, SAE straight thread and flanged porting
- Various Dirt Alarm® options

120 gpm
455 L/min
 100 psi
 7 bar

Model No. of filter in photograph is RTI3KZ10S24NP16Y2.

IRF
 TF1
 KF3
 KL3
 LF1
 MLF1
 RLD
 GRTB
 MTA
 MTB
 ZT
 AFT
 KFT
 RT

RTI

LRT
 ART
 BRT
 TRT
 BFT
 QT
 KTK
 LTK
 MRT

Flow Rating:	Up to 120 gpm (455 L/min) for 150 SUS (32 cSt) fluids
Max. Operating Pressure:	100 psi (7 bar)
Min. Yield Pressure:	400 psi (28 bar), per NFPA T2.6.1
Rated Fatigue Pressure:	Contact factory
Temp. Range:	-20°F to 225°F (-29°C to 107°C)
Bypass Setting:	Cracking: 25 psi (2 bar) Full Flow: 62 psi (4.3 bar)
Porting Head & Cap:	Die Cast Aluminum
Element Case:	Steel
Weight of RTI-KI:	11.4 lbs. (5.2 kg)
Weight of RTI-KKI:	14.5 lbs. (6.6 kg)
Element Change Clearance:	KI Element = 9.0 (229 mm) KKI Element = 18.0 (457 mm) 27KI Element = 27.0 (686 mm)

Filter Housing Specifications

Type Fluid	Appropriate Schroeder Media
Petroleum Based Fluids	All E media (cellulose), Z-Media® and ASP® media (synthetic)
High Water Content	All Z-Media® and ASP® media (synthetic)
Invert Emulsions	10 and 25 µ Z-Media® and 10 µ ASP® media (synthetic)
Water Glycols	3, 5, 10 and 25 µ Z-Media® and all ASP® media (synthetic)
Phosphate Esters	All Z-Media® (synthetic) with H (EPR) seal designation and all ASP® media (synthetic)
Skydrol®	3, 5, 10 and 25 µ Z-Media® (synthetic) with H.5 seal designation (EPR seals and stainless steel wire mesh in element, and light oil coating on housing exterior) and all ASP® media (synthetic)

Fluid Compatibility

Accessories
 For Tank-Mounted
 Filters

PAF1
 MAF1
 MF2

Tank-Mounted Filter (Inside Out Flow)

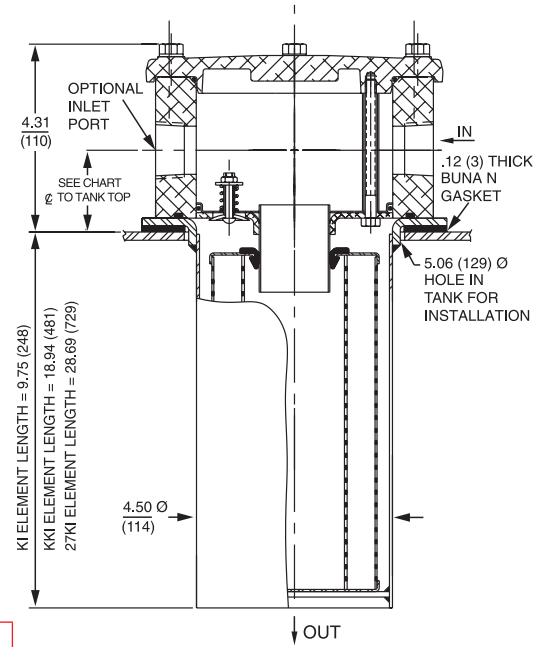
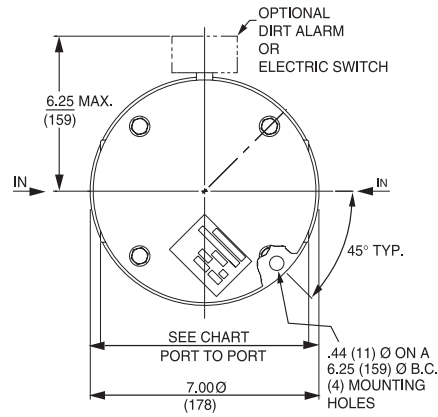

	1 1/4", 1 1/2" Standard Ports	1 1/2" Ports 4-Bolt Flange Only
Port to Port	6.38"	7.12"
☉ to Casting Base	1.56"	1.75"
☉ to Tank Top	1.88"	2.06"

Optional mounting rings available for tank welding. See page 307, reference part numbers A-LFT-813 and A-LFT-1448.

Metric dimensions in ().

Element Performance Information & Dirt Holding Capacity

Element	Filtration Ratio Per ISO 4572/NFPA T3.10.8.8 Using automated particle counter (APC) calibrated per ISO 4402			Filtration Ratio per ISO 16889 Using APC calibrated per ISO 11171	
	$\beta_x \geq 75$	$\beta_x \geq 100$	$\beta_x \geq 200$	$\beta_x(c) \geq 200$	$\beta_x(c) \geq 1000$
KIZ1	<1.0	<1.0	<1.0	<4.0	4.2
KIZ3	<1.0	<1.0	<2.0	<4.0	4.8
KIZ10	<7.4	<8.2	<10.0	8.0	10.0

Element	DHC (gm)	Element	DHC (gm)	Element	DHC (gm)
KIZ1	85	KKIZ1	181	27KIZ1	276
KIZ3	88	KKIZ3	185	27KIZ3	283
KIZ10	<82	KKIZ10	174	27KIZ10	266

Element Collapse Rating: 100 psid (7 bar)

Flow Direction: Inside Out

Element Nominal Dimensions: KI: 3.9" (99 mm) O.D. x 9.0" (230 mm) long
 KK: 3.9" (99 mm) O.D. x 18.0" (460 mm) long
 27KI: 3.9" (99 mm) O.D. x 27.0" (690 mm) long

Tank-Mounted Filter (Inside Out Flow)

RTI

$\Delta P_{\text{housing}}$

RTI $\Delta P_{\text{housing}}$ for fluids with sp gr (specific gravity) = 0.86:

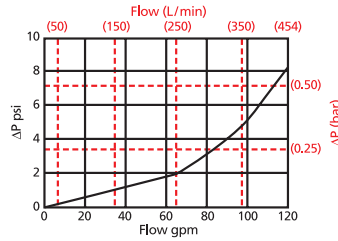

$\Delta P_{\text{element}}$

KIZ

Element Pressure Drop versus Flow Rate at 32 cSt (150 SUS)

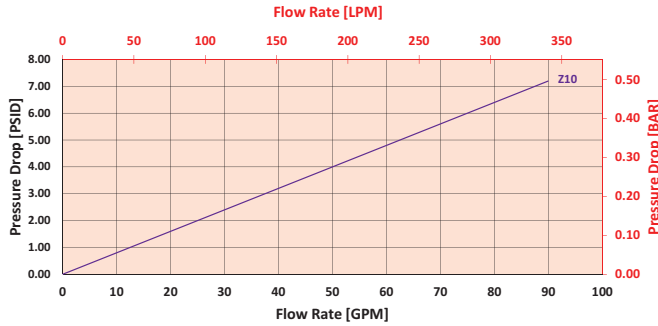

KKIZ

Element Pressure Drop versus Flow Rate at 32 cSt (150 SUS)

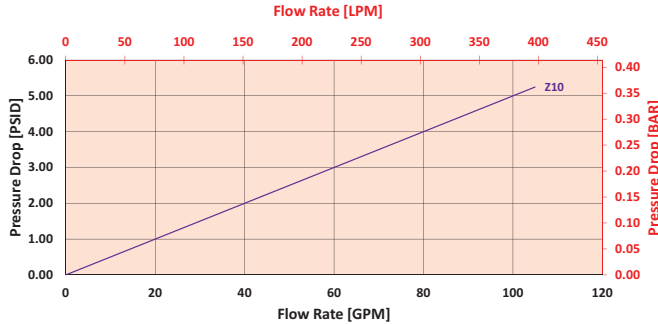

$$\Delta P_{\text{filter}} = \Delta P_{\text{housing}} + (\Delta P_{\text{element}} * V_f)$$

Exercise:

Determine ΔP_{filter} at 80 gpm (303.2 L/min) for RTIKIZ10S20S20NY2 using 160 SUS (34 cSt) fluid.

Use the housing pressure curve to determine $\Delta P_{\text{housing}}$ at 80 gpm. In this case, $\Delta P_{\text{housing}}$ is 3 psi (.21 bar) on the graph for the RTI housing.

Use the element pressure curve to determine $\Delta P_{\text{element}}$ at 80 gpm. In this case, $\Delta P_{\text{element}}$ is 6.5 psi (.45 bar) according to the graph for the KIZ10 element.

Because the viscosity in this sample is 160 SUS (34 cSt), we determine the Viscosity Factor (V_f) by dividing the Operating Fluid Viscosity with the Standard Viscosity of 150 SUS (32 cSt). To best determine your Operating Fluid Viscosity, please reference the chart in Appendix D.

Finally, the overall filter pressure differential, ΔP_{filter} , is calculated by adding $\Delta P_{\text{housing}}$ with the true element pressure differential, ($\Delta P_{\text{element}} * V_f$). The $\Delta P_{\text{element}}$ from the graph has to be multiplied by the viscosity factor to get the true pressure differential across the element.

Solution:

$$\Delta P_{\text{housing}} = 3 \text{ psi } [.21 \text{ bar}] \mid \Delta P_{\text{element}} = 6.5 \text{ psi } [.45 \text{ bar}]$$

$$V_f = 160 \text{ SUS (34 cSt) } / 150 \text{ SUS (32 cSt)} = 1.1$$

$$\Delta P_{\text{filter}} = 3 \text{ psi } + (6.5 \text{ psi } * 1.1) = 10.2 \text{ psi}$$

OR

$$\Delta P_{\text{filter}} = .21 \text{ bar } + (.45 \text{ bar } * 1.1) = .71 \text{ bar}$$

Pressure Drop Information Based on Flow Rate and Viscosity

Note: If your element is not graphed, use the following equation:
 $\Delta P_{\text{element}} = \text{Flow Rate} \times \Delta P_f$ Plug this variable into the overall pressure drop equation.

Ele.	ΔP
KIAS10	0.08
KKIAS10	0.05
27KIAS10/ 27KIAS10	0.04

Filter Model Number Selection

How to Build a Valid Model Number for a Schroeder RTI:

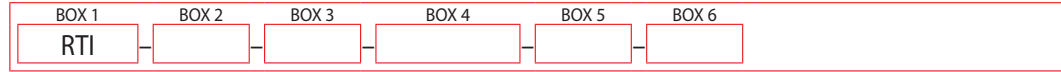

Example: NOTE: Only box 6 may contain more than one option

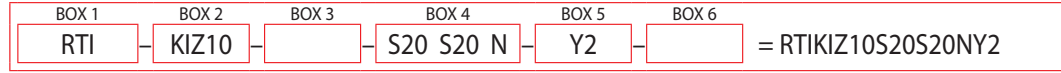

Filter Series	Element Part Number			
RTI	K Length	KK Length	27K Length	
	KIZ1	KKIZ1	27KIZ1	= 1 μ Excellement® Z-Media® and ASP® media (synthetic)
	KIZ3	KKIZ3	27KIZ3	= 3 μ Excellement® Z-Media® and ASP® media (synthetic)
	KIZ10	KKIZ10	27KIZ10	= 10 μ Excellement® Z-Media® and ASP® media (synthetic)

Seal Material
Omit = Buna N
H = EPR
W = Anodized Aluminum Parts
H.5 = Skydrol® Compatibility

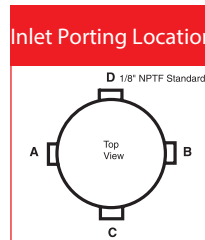

BOX 4 Specification of all 3 ports is required

Inlet Porting		
Port A	Port B	Port C
P16 = 1" NPTF	N = None	N = None
P20 = 1¼" NPTF	P16 = 1" NPTF	P2 = ⅜" NPTF
P24 = 1½" NPTF	P20 = 1¼" NPTF	P16 = 1" NPTF
S16 = SAE-16	P24 = 1½" NPTF	S16 = SAE-16
S20 = SAE-20	S16 = SAE-16	
S24 = SAE-24	S20 = SAE-20	
F20 = 1¼" SAE 4-bolt flange Code 61	S24 = SAE-24	
F24 = 1½" SAE 4-bolt flange Code 61	F20 = 1¼" SAE 4-bolt flange Code 61	
	F24 = 1½" SAE 4-bolt flange Code 61	

BOX 5

Dirt Alarm® Options	
Omit = None	
Located @ Port D	Visual Y2 = Back-mounted tri-color gauge
	Electrical ES = Electric switch
	ES1 = Heavy-duty electric switch with conduit connector
Located in cap	ES2 = Electrical Switch with Deutsch Connector
	Visual Y2C = Bottom-mounted tri-color gauge
Located @ Port C	Y5 = Back-mounted gauge in cap
	Visual Y2R = Back-mounted gauge mounted on opposite side of standard location
	Electrical ESR = Electric switch mounted on opposite side of standard location
	ES1R = Heavy-duty electric switch with conduit connector

BOX 6

Additional Options
Omit = None
G547 = Two ⅜" gauge ports
M = Metric thread for SAE 4-bolt flange mounting holes (specify after each port designation)

NOTES:

- Box 2. Replacement element part numbers are identical to contents of Boxes 2 and 3.
- Box 3. For options H, W, and H.5, all aluminum parts are anodized. H.5 seal designation includes the following: EPR seals, stainless steel wire mesh on elements, and light oil coating on housing exterior. Skydrol® is a registered trademark of Solutia Inc.
- Box 4. If using Port B, Port A & B must always be the same type and size. Example: (A) P20 (B) P20 (C) P16
- Box 6. See also "Accessories for Tank-Mounted Filters," page 307.

Tank-Mounted Filter

LRT



Features and Benefits

- Low pressure tank-mounted filter
- Multiple inlet/outlet porting options
- Top, side or bottom mounting
- Optional check valve prevents reservoir siphoning
- Can also be used in return line application (contact factory)
- Visual gauge or electrical switch dirt alarms
- Offered in pipe, SAE straight thread, flanged and ISO 228 porting
- Same day shipment model available
- Also available with DirtCatcher® elements (18LD)
- **G** Available with quality-protected GeoSeal® Elements (GLRT)

150 gpm
570 L/min
 100 psi
7 bar

Model No. of filter in photograph is LRT18LZ10S24NP16Y2.

IRF
 TF1
 KF3
 KL3
 LF1
 MLF1
 RLD
 GRTB
 MTA
 MTB
 ZT
 AFT
 KFT
 RT
 RTI

LRT

Flow Rating:	Up to 150 gpm (570 L/min) for 150 SUS (32 cSt) fluids
Max. Operating Pressure:	100 psi (7 bar)
Min. Yield Pressure:	400 psi (28 bar), per NFPA T2.6.1
Rated Fatigue Pressure:	90 psi (6 bar), per NFPA T2.6.1-2005
Temp. Range:	-20°F to 225°F (-29°C to 107°C)
Bypass Setting:	Cracking: 25 psi (1.7 bar) Full Flow: 34 psi (2.3 bar)
Porting Head & Cap:	Die Cast Aluminum
Element Case:	Steel
Weight of LRT-18L:	14.6 lbs. (6.6 kg)
Element Change Clearance:	17.0" (432 mm)

Filter Housing Specifications

ART
 BRT
 TRT
 BFT
 QT
 KTK
 LTK
 MRT

Type Fluid	Appropriate Schroeder Media
Petroleum Based Fluids	All E media (cellulose) and Z-Media® (synthetic)
High Water Content	All Z-Media® (synthetic)
Invert Emulsions	10 and 25 µ Z-Media® (synthetic)
Water Glycols	3, 5, 10 and 25 µ Z-Media® (synthetic)
Phosphate Esters	All Z-Media® (synthetic) with H (EPR) seal designation
Skydrol®	3, 5, 10 and 25 µ Z-Media® (synthetic) with H.5 seal designation (EPR seals and stainless steel wire mesh in element, and light oil coating on housing exterior)

Fluid Compatibility

Accessories For Tank-Mounted Filters
 PAF1
 MAF1
 MF2

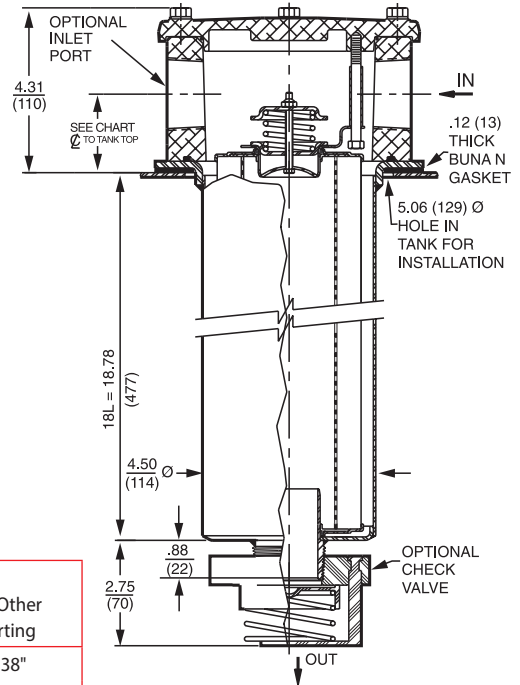
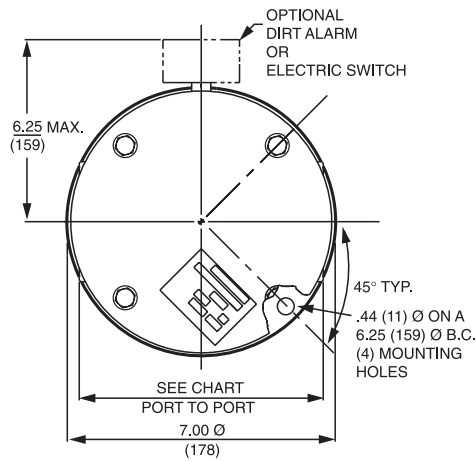

	1½" Ports 4-Bolt Flange Only	2" Ports	All Other Porting
Port to Port	7.12"	7.56" (P, S, B) 7.38" (F)	6.38"
℄ to Casting Base	1.75"	1.81"	1.56"
℄ to Tank Top	2.06"	2.12"	1.88"

Optional mounting ring available to weld to tank.

Metric dimensions in ().

Element Performance Information & Dirt Holding Capacity

Element	Filtration Ratio Per ISO 4572/NFPA T3.10.8.8 Using automated particle counter (APC) calibrated per ISO 4402			Filtration Ratio per ISO 16889 Using APC calibrated per ISO 11171	
	$\beta_x \geq 75$	$\beta_x \geq 100$	$\beta_x \geq 200$	$\beta_x(c) \geq 200$	$\beta_x(c) \geq 1000$
18LZ1	<1.0	<1.0	<1.0	<4.0	4.2
18LZ3	<1.0	<1.0	<2.0	<4.0	4.8
18LZ5	2.5	3.0	4.0	4.8	6.3
18LZ10	7.4	8.2	10.0	8.0	10.0
18LZ25	18.0	20.0	22.5	19.0	24.0

Element	DHC (gm)	Element	DHC (gm)
18LZ1	224	18LDZ1	194
18LZ3	230	18LDZ3	199
18LZ5	238	18LDZ5	194
18LZ10	216	18LDZ10	186
18LZ25	186	18LDZ25	169

Element Collapse Rating: 150 psid (10 bar)

Flow Direction: Outside In

Element Nominal Dimensions: 4.0" (100 mm) O.D. x 18.5" (470 mm) long

$\Delta P_{\text{housing}}$

LRT $\Delta P_{\text{housing}}$ for fluids with sp gr (specific gravity) = 0.86:

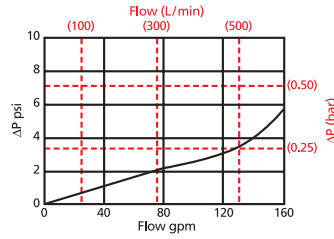

$\Delta P_{\text{element}}$

18LZ

Element Pressure Drop versus Flow Rate at 32 cSt (150 SUS)

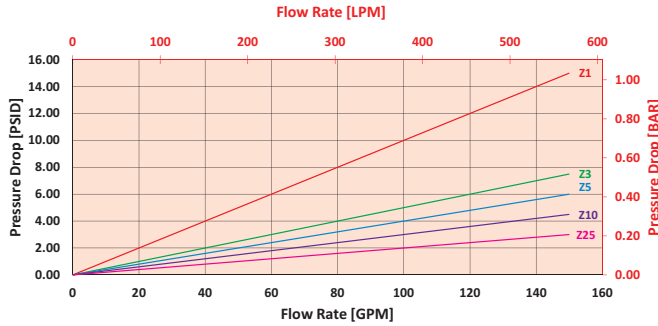

$$\Delta P_{\text{filter}} = \Delta P_{\text{housing}} + (\Delta P_{\text{element}} * V_f)$$

Exercise:

Determine ΔP_{filter} at 120 gpm (379 L/min) for LRT18LZ10S24S24NY2 using 160 SUS (34 cSt) fluid.

Use the housing pressure curve to determine $\Delta P_{\text{housing}}$ at 120 gpm. In this case, $\Delta P_{\text{housing}}$ is 3 psi (.21 bar) on the graph for the LRT housing.

Use the element pressure curve to determine $\Delta P_{\text{element}}$ at 120 gpm. In this case, $\Delta P_{\text{element}}$ is 4 psi (.27 bar) according to the graph for the 18LZ10 element.

Because the viscosity in this sample is 160 SUS (34 cSt), we determine the Viscosity Factor (V_f) by dividing the Operating Fluid Viscosity with the Standard Viscosity of 150 SUS (32 cSt). To best determine your Operating Fluid Viscosity, please reference the chart in Appendix D.

Finally, the overall filter pressure differential, ΔP_{filter} , is calculated by adding $\Delta P_{\text{housing}}$ with the true element pressure differential, ($\Delta P_{\text{element}} * V_f$). The $\Delta P_{\text{element}}$ from the graph has to be multiplied by the viscosity factor to get the true pressure differential across the element.

Solution:

$\Delta P_{\text{housing}} = 3 \text{ psi } [.21 \text{ bar}] \mid \Delta P_{\text{element}} = 4 \text{ psi } [.27 \text{ bar}]$

$V_f = 160 \text{ SUS (34 cSt)} / 150 \text{ SUS (32 cSt)} = 1.1$

$\Delta P_{\text{filter}} = 3 \text{ psi} + (4 \text{ psi} * 1.1) = 7.4 \text{ psi}$

OR

$\Delta P_{\text{filter}} = .21 \text{ bar} + (.27 \text{ bar} * 1.1) = .51 \text{ bar}$

Pressure Drop Information Based on Flow Rate and Viscosity

Note: If your element is not graphed, use the following equation:
 $\Delta P_{\text{element}} = \text{Flow Rate} \times \Delta P_f$. Plug this variable into the overall pressure drop equation.

Ele.	ΔP
18LDZ1	0.12
18LDZ3	0.06
18LDZ5	0.05
18LDZ10	0.03
18LDZ25	0.02

Filter Model Number Selection

Highlighted product eligible for **QuickDelivery**

How to Build a Valid Model Number for a Schroeder LRT:

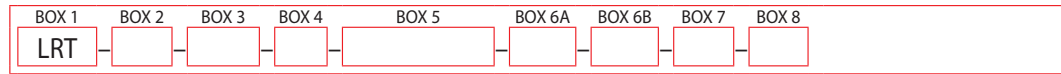

Example: NOTE: Only box 8 may contain more than one option

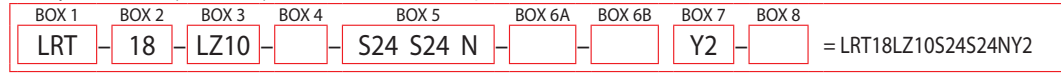

BOX 1	BOX 2	BOX 3	BOX 4
Filter Series	Element Length (in)	Element Size and Media	
LRT	18	L3 = L size 3 μ E media (cellulose) L10 = L size 10 μ E media (cellulose) LZ1 = L size 1 μ Excellement® Z-Media® (synthetic) LZ3 = L size 3 μ Excellement® Z-Media® (synthetic) LZ5 = L size 5 μ Excellement® Z-Media® (synthetic) LZ10 = L size 10 μ Excellement® Z-Media® (synthetic) LZ25 = L size 25 μ Excellement® Z-Media® (synthetic) LDZ1 = L size DirtCatcher® 1 μ Excellement® Z-Media® LDZ3 = L size DirtCatcher® 3 μ Excellement® Z-Media® LDZ5 = L size DirtCatcher® 5 μ Excellement® Z-Media® LDZ10 = L size DirtCatcher® 10 μ Excellement® Z-Media® LDZ25 = L size DirtCatcher® 25 μ Excellement® Z-Media® GeoSeal® Element Options LGZ1 = L size 1 μ Excellement® Z-Media® (synthetic) LGZ3 = L size 3 μ Excellement® Z-Media® (synthetic) LGZ5 = L size 5 μ Excellement® Z-Media® (synthetic) LGZ10 = L size 10 μ Excellement® Z-Media® (synthetic) LGZ25 = L size 25 μ Excellement® Z-Media® (synthetic)	
GLRT (GeoSeal®)		Seal Material	
		Omit = Buna N H = EPR W = Anodized Aluminum Parts H.5 = Skydrol® compatibility	

BOX 5
Specification of all 3 ports is required

Inlet Porting			BOX 6A
Port A	Port B	Port C	Bypass Option
P16 = 1" NPTF P20 = 1¼" NPTF P24 = 1½" NPTF P32 = 2" NPTF S16 = SAE-16 S20 = SAE-20 S24 = SAE-24 S32 = SAE-32 F20 = 1¼" SAE 4-bolt flange Code 61 F24 = 1½" SAE 4-bolt flange Code 61 F32 = 2" SAE 4-bolt flange Code 61 B24 = ISO 228 G-1½" Flange port option only: M = Metric SAE 4 bolt flange	N = None P16 = 1" NPTF P20 = 1¼" NPTF P24 = 1½" NPTF P32 = 2" NPTF S16 = SAE-16 S20 = SAE-20 S24 = SAE-24 S32 = SAE-32 F20 = 1¼" SAE 4-bolt flange Code 61 F24 = 1½" SAE 4-bolt flange Code 61 F32 = 2" SAE 4-bolt flange Code 61 B24 = ISO 228 G-1½"	N = None P2 = ½" NPTF P16 = 1" NPTF S16 = SAE-16 Inlet Porting Location 	Omit = 25 psi bypass setting 40 = 40 psi bypass setting
			BOX 6B
			Outlet Porting Options
			Omit = 2" NPT male C = Check valve D = Diffuser T = 13" Tube ext. A = Non-thread outlet

NOTES:

Box 2. Replacement element part numbers are a combination of Boxes 2, 3, and 4. Example: 18LZ10

Box 4. For options H, W, and H.5, all aluminum parts are anodized. H.5 seal designation includes the following: EPR seals, stainless steel wire mesh on elements, and light oil coating on housing exterior. Skydrol® is a registered trademark of Solutia Inc.

Box 5. If using Port B, Port A & B must always be the same type and size. Example: (A) P20 (B) P20 (C) P16.

Box 6. See also "Accessories for Tank-Mounted Filters," page 307.

BOX 7

Dirt Alarm® Options	
Omit = None	
Located @ Port D	Visual Y2 = Back-mounted tri-color gauge ES = Electric switch ES1 = Heavy-duty electric switch with conduit connector ES2 = Electrical Switch with Deutsch Connector ES3 = Electric Switch with DIN 43650
Located in cap	Visual Y2C = Bottom-mounted tri-color gauge Y5 = Back-mounted gauge in cap
Located @ Port C	Visual Y2R = Back-mounted gauge mounted on opposite side of standard location ESR = Electric switch mounted on opposite side of standard location ES1R = Heavy-duty electric switch with conduit connector

BOX 8

Add. Options
Omit = None
G2293 = Cork gasket
G547 = Two ½" gauge ports
G820 = Stamped cap

Tank-Mounted Filter

ART



Features and Benefits

- Compact, lightweight, low pressure tank mounted filter ideal for mobile applications
- Lightweight plastic bowl
- ART aluminum alloy is designed to be water tolerant - anodization is not required for use with water based fluids (HWCF).
- Special filter element design provides aftermarket benefits.
- Various Dirt Alarm® options

225 gpm
850 L/min
145 psi
10 bar

Model No. of filter in photograph is ART85Z10F43.

Flow Rating:	Up to 225 gpm (850 L/min) for 150 SUS (32 cSt) fluids
Max. Operating Pressure:	145 psi (10 bar)
Min. Yield Pressure:	535 psi (37 bar), per NFPA T2.6.1
Rated Fatigue Pressure:	145 psi (10 bar), per NFPA T2.6.1
Temp. Range:	-20°F to 225°F (-29°C to 107°C)
Bypass Setting:	Cracking: 43 psi (3 bar) Full Flow: 69 psi (4.75 bar)
Porting Head & Cap:	Aluminum
Element Case:	Plastic
Weight of ART:	15 lbs. (7 kg)
Element Change Clearance:	16.39" (340 mm)

Filter Housing Specifications

Type Fluid	Appropriate Schroeder Media
Petroleum Based Fluids	All Z-Media® (synthetic)
High Water Content	All Z-Media® (synthetic)

Fluid Compatibility

Accessories For Tank-Mounted Filters

- IRF
- TF1
- KF3
- KL3
- LF1
- MLF1
- RLD
- GRTB
- MTA
- MTB
- ZT
- AFT
- KFT
- RT
- RTI
- LRT
- ART**
- BRT
- TRT
- BFT
- QT
- KTK
- LTK
- MRT
- PAF1
- MAF1
- MF2

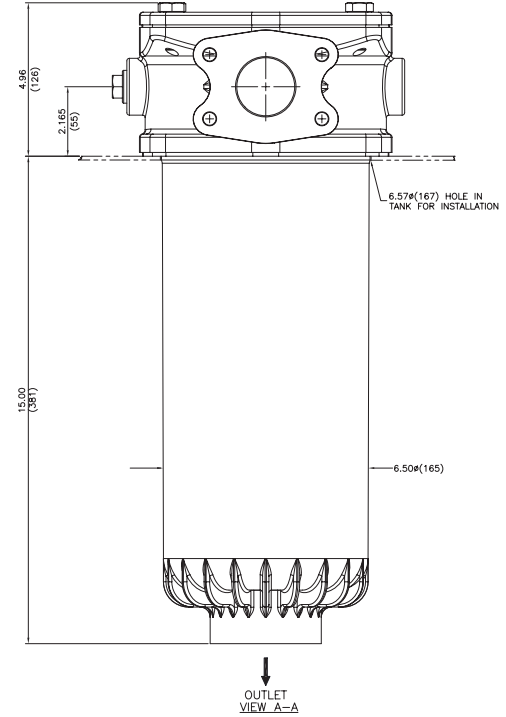
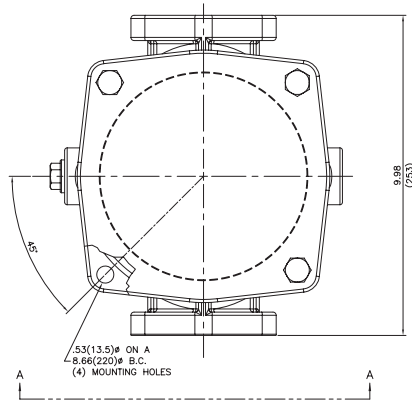

Metric dimensions in ().

Element
Performance
Information & Dirt
Holding Capacity

Element	Filtration Ratio per ISO 16889 Using APC calibrated per ISO 11171	
	$\beta_x(c) \geq 200$	$\beta_x(c) \geq 1000$
85Z1	<4.0	4.2
85Z3	<4.0	4.8
85Z5	4.8	6.3
85Z10	8.0	10.0
85Z25	19.0	24.0

Element	DHC (gm)
85Z1	185
85Z3	147
85Z5	206
85Z10	164
85Z25	167

Element Collapse Rating: 150 psid (10 bar)
 Flow Direction: Outside In
 Element Nominal Dimensions: 4.5" (114.3 mm) O.D. x 13.8" (350.52 mm) long

$\Delta P_{\text{housing}}$

ART $\Delta P_{\text{housing}}$ for fluids with sp gr (specific gravity) = 0.86:

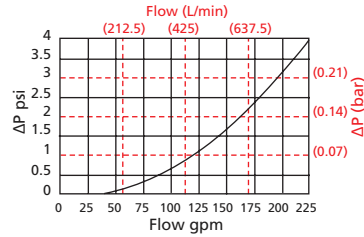

$\Delta P_{\text{element}}$

85Z

Element Pressure Drop versus Flow Rate at 32 cSt (150 SUS)

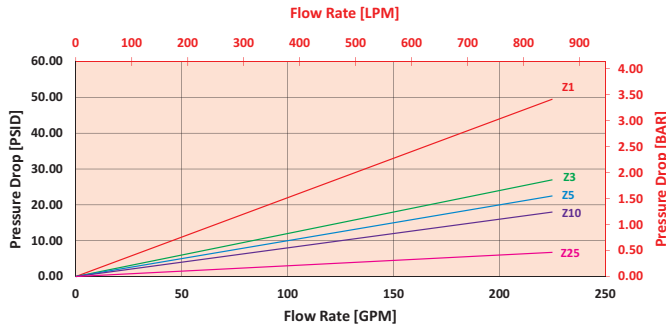

$$\Delta P_{\text{filter}} = \Delta P_{\text{housing}} + (\Delta P_{\text{element}} * V_f)$$

Exercise:

Determine ΔP_{filter} at 120 gpm (379 L/min) for ART85Z10F43Y2 using 160 SUS (34 cSt) fluid.

Use the housing pressure curve to determine $\Delta P_{\text{housing}}$ at 120 gpm. In this case, $\Delta P_{\text{housing}}$ is 1 psi (.07 bar) on the graph for the ART housing.

Use the element pressure curve to determine $\Delta P_{\text{element}}$ at 120 gpm. In this case, $\Delta P_{\text{element}}$ is 10 psi (.69 bar) according to the graph for the 85Z10 element.

Because the viscosity in this sample is 160 SUS (34 cSt), we determine the Viscosity Factor (V_f) by dividing the Operating Fluid Viscosity with the Standard Viscosity of 150 SUS (32 cSt). To best determine your Operating Fluid Viscosity, please reference the chart in Appendix D.

Finally, the overall filter pressure differential, ΔP_{filter} , is calculated by adding $\Delta P_{\text{housing}}$ with the true element pressure differential, ($\Delta P_{\text{element}} * V_f$). The $\Delta P_{\text{element}}$ from the graph has to be multiplied by the viscosity factor to get the true pressure differential across the element.

Solution:

$$\Delta P_{\text{housing}} = 1 \text{ psi } [.07 \text{ bar}] \quad | \quad \Delta P_{\text{element}} = 10 \text{ psi } [.69 \text{ bar}]$$

$$V_f = 160 \text{ SUS (34 cSt)} / 150 \text{ SUS (32 cSt)} = 1.1$$

$$\Delta P_{\text{filter}} = 1 \text{ psi} + (10 \text{ psi} * 1.1) = 12 \text{ psi}$$

OR

$$\Delta P_{\text{filter}} = .07 \text{ bar} + (.69 \text{ bar} * 1.1) = .83 \text{ bar}$$

Pressure Drop Information Based on Flow Rate and Viscosity

Filter Model Number Selection

How to Build a Valid Model Number for a Schroeder ART:

BOX 1	BOX 2	BOX 3	BOX 4	BOX 5	BOX 6	BOX 7
ART						

Example: NOTE: One option per box

BOX 1	BOX 2	BOX 3	BOX 4	BOX 5	BOX 6	BOX 7
ART	85Z10		F	43		Y2

= ART85Z10F43Y2

BOX 1	BOX 2	BOX 3
Filter Series	Element Size and Media	Seal Material
ART	85Z1 = 1 μ Excellement® Z-Media® (synthetic) 85Z3 = 3 μ Excellement® Z-Media® (synthetic) 85Z5 = 5 μ Excellement® Z-Media® (synthetic) 85Z10 = 10 μ Excellement® Z-Media® (synthetic) 85Z25 = 25 μ Excellement® Z-Media® (synthetic)	Omit = Buna N H = EPR
	BOX 4	BOX 5
	Porting	Bypass Setting
	F = 2½" SAE-40 4-bolt flange Code 61 FF = Dual 2½" SAE-40 4-bolt flange Code 61 S = SAE-32 SS = Dual SAE-32	43 = 43 psi Bypass
		BOX 6
		Outlet Options
		Omit = 2" Threadless Outlet
		BOX 7
		Dirt Alarm® Options
		Omit = None
	Visual	Y2 = Back-mounted tri-color gauge Y2R = Back-mounted gauge mounted on opposite side of standard location
	Electrical	ES = Electric switch (normally open) ESR = Electric switch mounted on opposite side of standard location ES1 = Heavy-duty electric switch with conduit connector ES1R = Heavy-duty electric switch with conduit connector mounted on opposite side of standard location ES2 = Super duty electric switch with Thermal Lockout and 2 pin Deutsche connector (DT04-2P, SPST, normally closed)

NOTES:

Box 2. Replacement element part numbers are identical to contents of Boxes 2 and 3.

Box 3. For option H, all aluminum parts are anodized.

Return Line Filter

BRT



Features and Benefits

- Filter is mounted in the tank and flow comes to it from a pipe connection below it or from the side
- Optimal flow conditions created by flow from beneath guaranteeing optimal air separation, even tank mixing, and long element service intervals
- Patented de-aeration windows around the housing offer superior air bubble coalescence in a 360 degree discharge
- Quality Protected Inside-Out Flow Element Design



Part of the Schroeder Industries Energy Sustainability Initiative

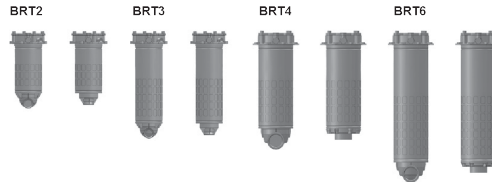

Model No. of filter in photograph is BRT6RBZ102.

to 160 gpm
to 600 L/min
to 145 psi
to 10 bar

Flow Rating:	Up to 160 gpm (600 L/min) for 150 SUS (32 cSt) fluids
Max. Operating Pressure:	145 psi (10 bar)
Temp. Range:	-22°F to 248°F (-30°C to 120°C)
Bypass Setting:	Cracking: 36 psi (2.5 bar)
Filter Head & Cover:	BRT 2 - 6: Aluminum
Inlet Section:	Nylon (PA66)
Seals	Buna N
Installation:	As in-tank filter

Filter Housing Specifications

- IRF
- TF1
- KF3
- KL3
- LF1
- MLF1
- RLD
- GRTB
- MTA
- MTB
- ZT
- AFT
- KFT
- RT
- RTI
- LRT
- ART
- BRT**
- TRT
- BFT
- QT
- KTK
- LTK
- MRT

Type Fluid	Appropriate Schroeder Media
Hydraulic Oils	Schroeder Z-Media® (synthetic)
Lubrication Oils	Schroeder Z-Media® (synthetic)
Compressor Oils	Schroeder Z-Media® (synthetic)
Biodegradable Operating Fluids	Schroeder Z-Media® (synthetic)

Fluid Compatibility

Accessories For Tank-Mounted Filters

- PAF1
- MAF1
- MF2

Dimensions BRT2 - BRT3

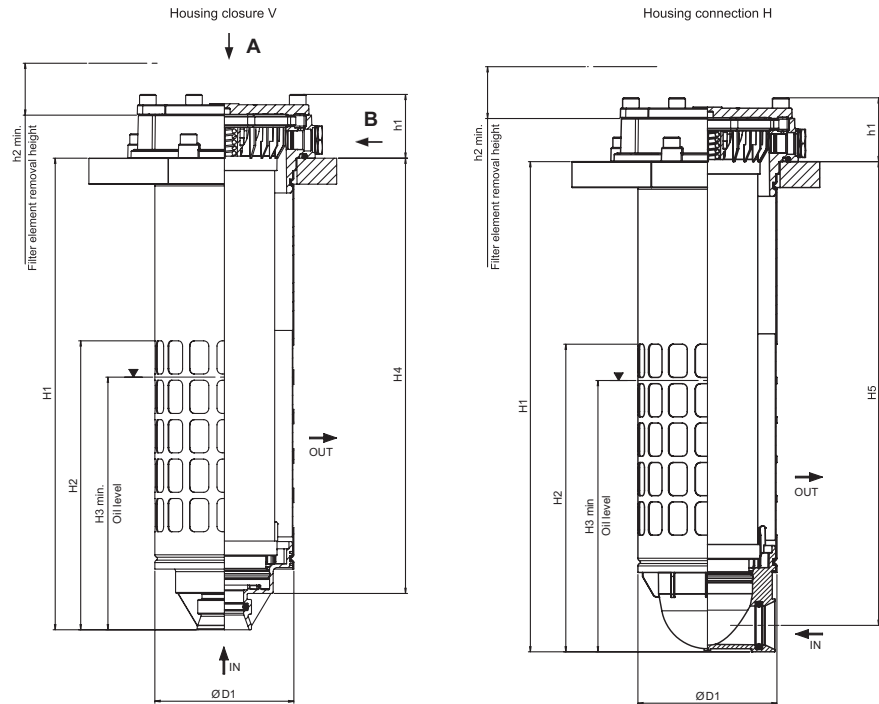
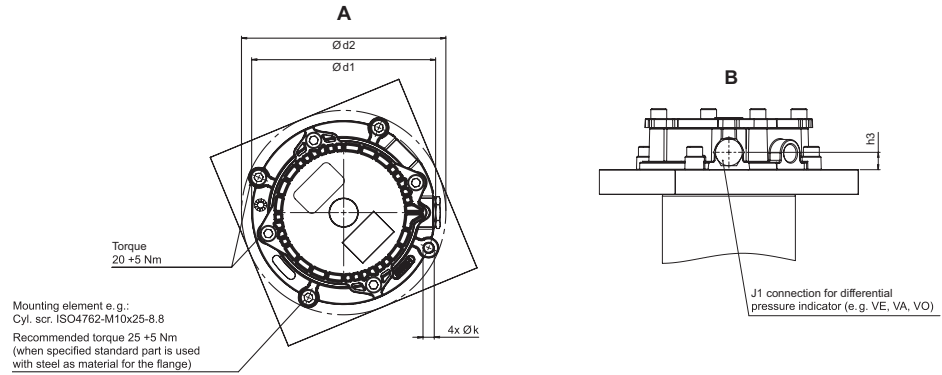

Type	Design	Connection pos.	H1	H2	H3	H4	H5	h1	h2	h3	$\varnothing D1$	$\varnothing d1$	$\varnothing d2$	$\varnothing k$	Weight [kg]
RFB 0170	Diffuser with opening	H	322.5	220.5	186	-	297	61.5	300	17.5	134	180	200	10.5	3.3
	Diffuser with opening	V	304.5	202.5	168	269.5	-								3.2
RFB 0300	Diffuser with opening	H	472.5	296.5	262	-	447	450							3.9
	Diffuser with opening	V	454.5	278.5	244	419.5	-								4.0

Element Performance Information

Element	Filtration Ratio Per ISO 4572/NFPA T3.10.8.8 Using automated particle counter (APC) calibrated per ISO 4402			Filtration Ratio per ISO 16889 Using APC calibrated per ISO 11171	
	$\beta_x \geq 75$	$\beta_x \geq 100$	$\beta_x \geq 200$	$\beta_x(c) \geq 200$	$\beta_x(c) \geq 1000$
2RBZ10	C/F	C/F	C/F	C/F	11.2
2RBZ25	C/F	C/F	C/F	C/F	16.2
3RBZ10	C/F	C/F	C/F	C/F	11.2
3RBZ25	C/F	C/F	C/F	C/F	16.2
4RBZ10	C/F	C/F	C/F	C/F	11.2
4RBZ25	C/F	C/F	C/F	C/F	16.2
6RBZ10	C/F	C/F	C/F	C/F	11.2
6RBZ25	C/F	C/F	C/F	C/F	16.2

Metric dimensions mm ().

Dimensions BRT4 - BRT6

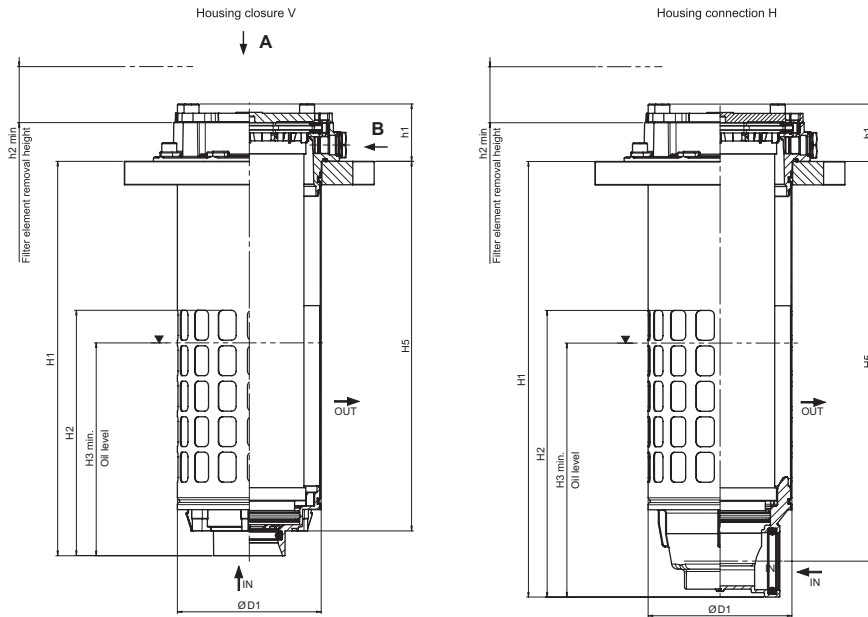
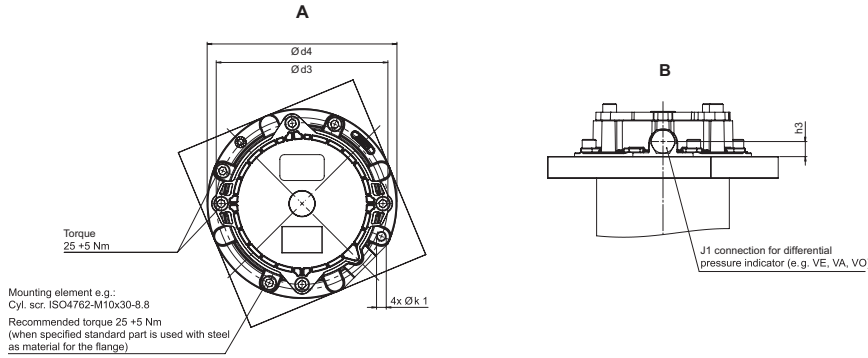

Type	Design	Connection pos.	H1	H2	H3	H4	H5	h1	h2	h3	ØD1	Ød1	Ød2	Øk1	Weight [kg]
RFB 0400	Diffuser with opening	H	466.5	307	234	-	428	61.5	430	17.5	154	185.7	205	10.5	4.5
	Diffuser with opening	V	422.4	262.6	182	393.8	-		580						4.3
RFB 0600	Diffuser with opening	H	613.7	383.2	310	-	575.2	61.5	580	17.5	154	185.7	205	10.5	5.5
	Diffuser with opening	V	561.6	331.1	258	541	-		580						5.3

Element	DHC (g)	Element	DHC (g)
2RBZ10	70.4	4RBZ10	152.5
2RBZ25	77.8	4RBZ25	173.4
3RBZ10	114.3	6RBZ10	190.4
3RBZ25	128.3	6RBZ25	231.7

Element Burst Rating: 87 psi (6 bar) for standard elements
Flow Direction: Inside Out

Element
Dirt Holding
Capacity & Burst Rating

Dimensions BRT2 - BRT3

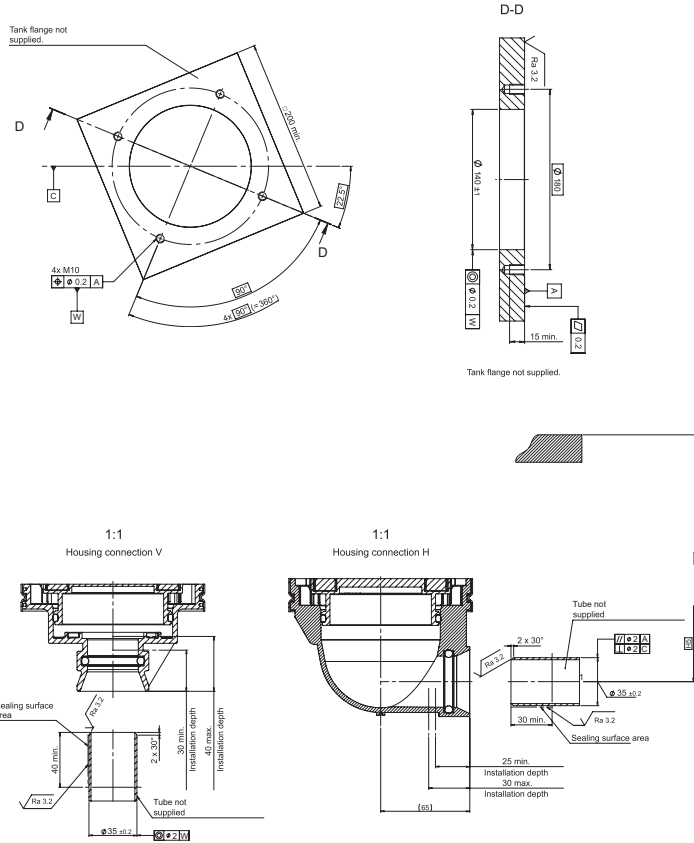

Dimensions BRT4 - BRT6

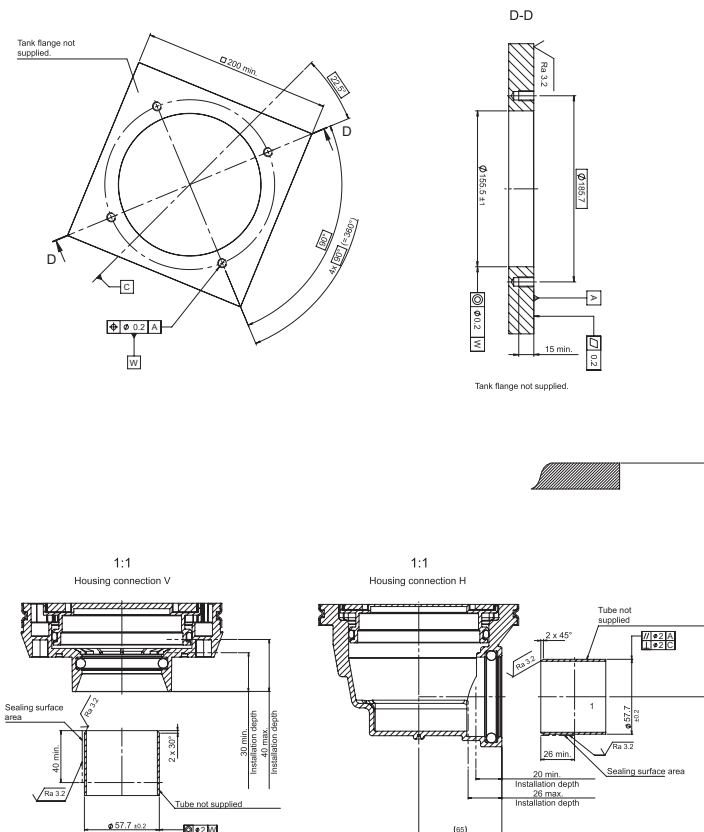

Metric dimensions mm ().

$\Delta P_{\text{element}}$
BRT2

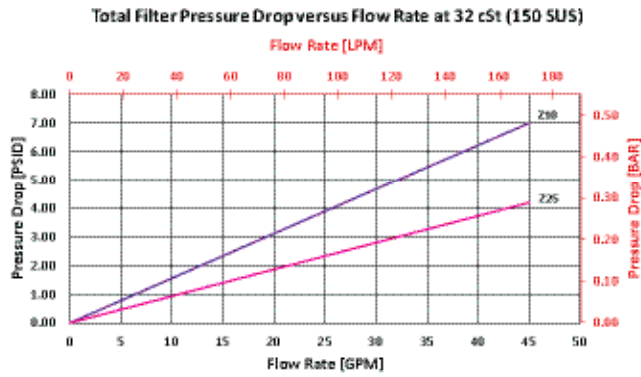

Pressure Drop Information Based on Flow Rate and Viscosity

BRT3

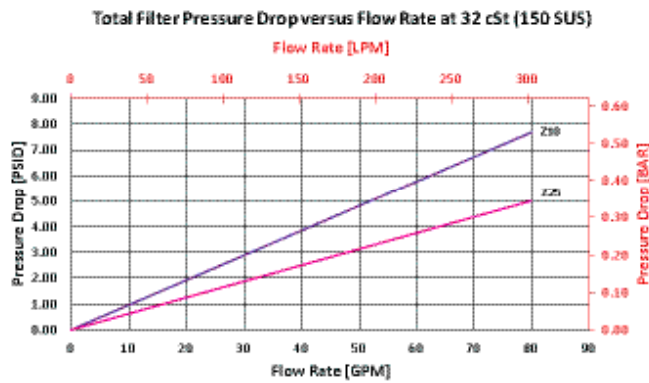

BRT4

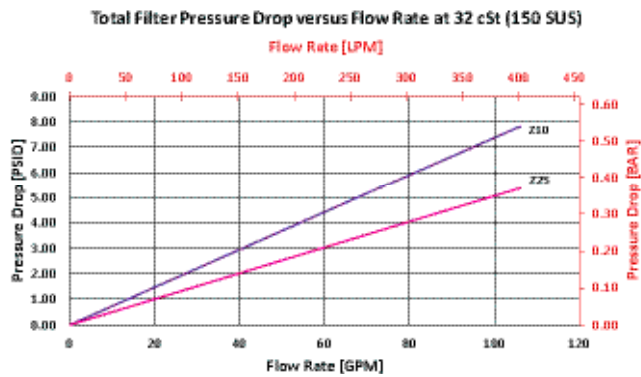

BRT6

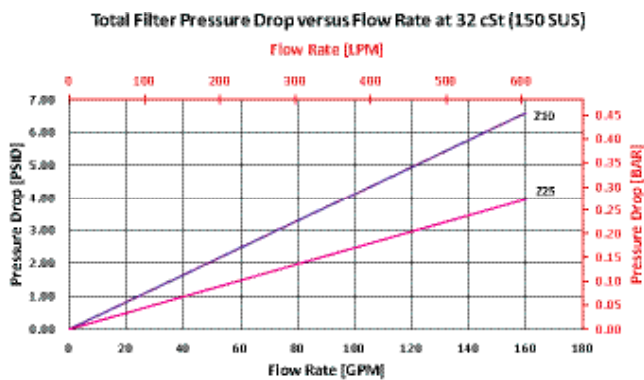

Filter
Model
Number
Selection

How to Build a Valid Model Number for a Schroeder BRT:

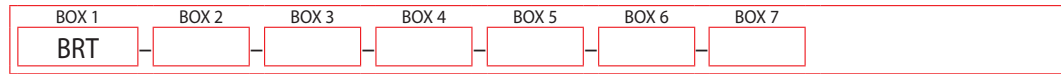

Example: NOTE: One option per box

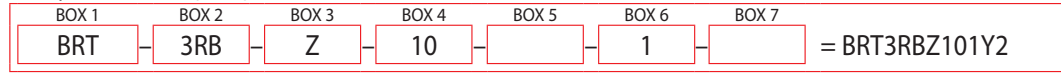

BOX 1	BOX 2	BOX 3	BOX 4
Filter Series	Size of Element	Element Media Type	
BRT	2RB	Z = Excellement® Z-Media® (synthetic)	
	3RB		
	4RB		
	6RB		
		Micron Rating	
		10 = 10 µm	
		25 = 25 µm	

BOX 5	BOX 6	BOX 7
Seal Material	Inlet Porting	Dirt Alarm® Options
Omit = Buna N	2 = side inlet	Omit = No Indicator, sealed up w/ screw plug
V = Viton®	1 = bottom inlet	VA = visual/electrical
		VE = electrical
		VO = visual
		Clogging Indicators



Features and Benefits

- Filter head is mounted on the tank like a standard return-line filter solution
- The protective tube can be supplied in various optional versions: 1.) as a closed tube with the outlet opening facing downwards or with a closed base and rows of operating holes at the height of the tank's oil level 2.) with an optional magnetic core connected to the filter element guaranteeing effective magnetic pre-filtration
- Patented de-aeration windows around the housing offer superior air bubble coalescence in a 360 degree discharge
- Quality Protected Element Design



Part of the Schroeder Industries Energy Sustainability Initiative

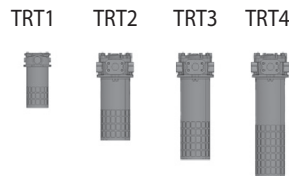

Model No. of filter in photograph is TRT3RTZ10MS.

up to 100 gpm
up to 380 L/min
 to 145 psi
 to 10 bar

Flow Rating:	Up to 100 gpm (400 L/min) for 150 SUS (32 cSt) fluids
Max. Operating Pressure:	145 psi (10 bar)
Temp. Range:	-22°F to 248°F (-30°C to 120°C)
Bypass Setting:	Cracking: 36 psi (2.5 bar)
Filter Head & Cover:	Aluminum
Filter Housing:	Steel
Inlet Section:	Nylon (PA66)
Seals:	Buna N and Viton
Installation:	As in-tank filter

Filter Housing Specifications

Type Fluid	Appropriate Schroeder Media
Hydraulic Oils	Schroeder Z-Media® (synthetic)
Lubrication Oils	Schroeder Z-Media® (synthetic)
Compressor Oils	Schroeder Z-Media® (synthetic)
Biodegradable Operating Fluids	Schroeder Z-Media® (synthetic)

Fluid Compatibility

Accessories For Tank-Mounted Filters

- IRF
- TF1
- KF3
- KL3
- LF1
- MLF1
- RLD
- GRTB
- MTA
- MTB
- ZT
- AFT
- KFT
- RT
- RTI
- LRT
- ART
- BRT
- TRT**
- BFT
- QT
- KTK
- LTK
- MRT
- PAF1
- MAF1
- MF2

Dimensions
TRT1, 2, 3, 4

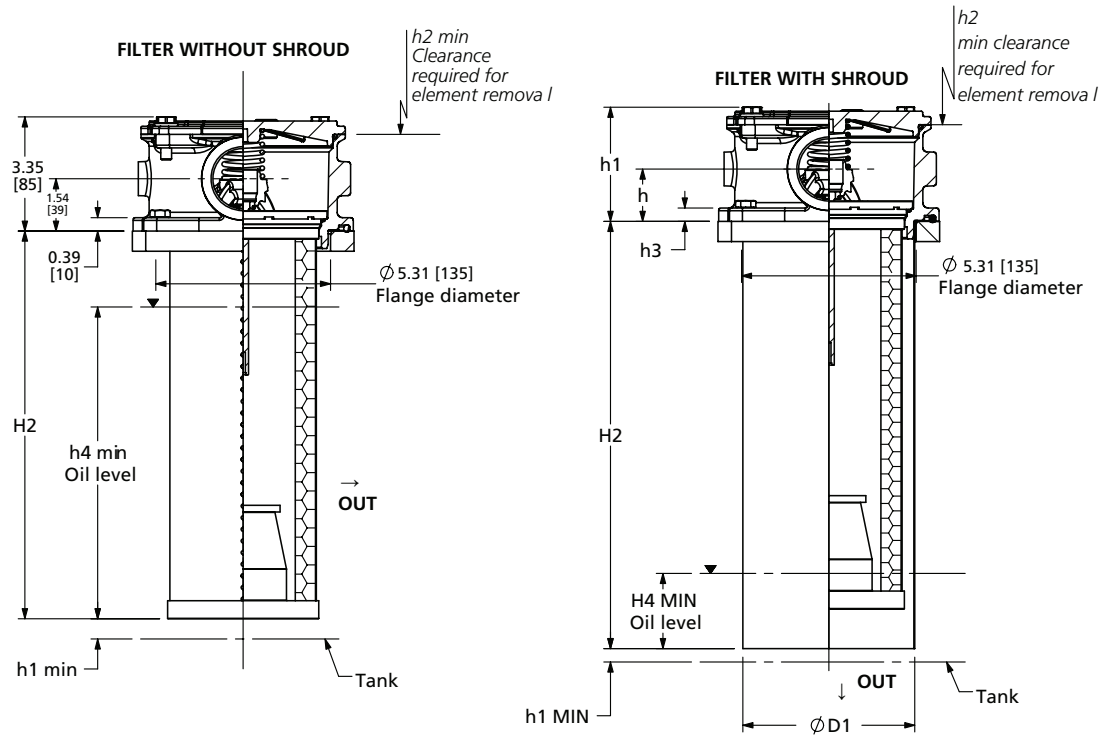

Element
Performance
Information

Element	Filtration Ratio Per ISO 4572/NFPA T3.10.8.8 Using automated particle counter (APC) calibrated per ISO 4402			Filtration Ratio per ISO 16889 Using APC calibrated per ISO 11171	
	$\beta_x \geq 75$	$\beta_x \geq 100$	$\beta_x \geq 200$	$\beta_x(c) \geq 200$	$\beta_x(c) \geq 1000$
1RTZ10	C/F	C/F	C/F	C/F	12.3
1RTZ25	C/F	C/F	C/F	C/F	16.2
2RTZ10	C/F	C/F	C/F	C/F	12.3
2RTZ25	C/F	C/F	C/F	C/F	18.6
3RTZ10	C/F	C/F	C/F	C/F	12.3
3RTZ25	C/F	C/F	C/F	C/F	18.6
4RTZ10	C/F	C/F	C/F	C/F	12.3
4RTZ25	C/F	C/F	C/F	C/F	18.6

Element
Dirt Holding
Capacity & Burst Rating

Element	DHC (g)	Element	DHC (g)
1RTZ10	81.0	3RTZ10	199.1
1RTZ25	89.9	3RTZ25	221.0
2RTZ10	150.5	4RTZ10	242.8
2RTZ25	167.1	4RTZ25	269.5

Element Burst Rating: 87 psi (6 bar) for standard elements
Flow Direction: Inside Out

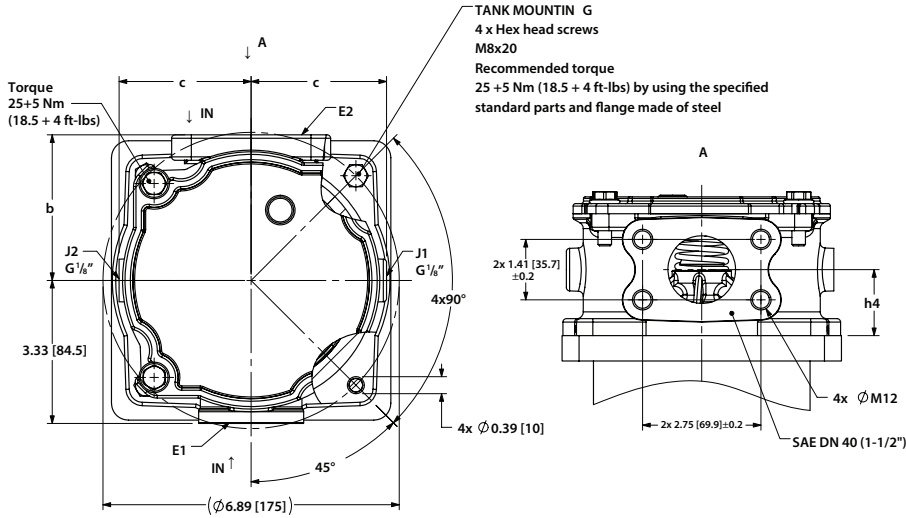

		H1	H2	H3	H4	h2	h4	ØD1	b	c	Weight (lbs [kg])
TRT1	No housing tube	0.39 [10]	8.58 [218]	-	6.10 [155]	10.24 [260]		-			5.7 [2.6]
	Standard housing with diffuser	0.20 [5]	9.72 [247]	4.02 [102]	0.39 [10]						5.04 [128]
TRT2	No housing tube	0.39 [10]	11.38 [289]	-	7.99 [203]	12.99 [330]		-			6.38 [2.9]
	Standard housing with diffuser	0.20 [5]	12.52 [318]	4.02 [102]	0.39 [10]						5.04 [128]
TRT3	No housing tube	0.39 [10]	15.16 [385]	-	10.51 [267]	16.96 [430]		-	3.39 [86.0]*	3.14 [80]*	6.82 [3.1]
	Standard housing with diffuser	0.20 [5]	16.30 [414]	4.02 [102]	0.39 [10]						5.04 [128]
TRT4	No housing tube	0.39 [10]	19.65 [499]	-	13.23 [336]	21.26 [540]	1.54 [39]	-	3.33 [78]**	3.07 [78]**	7.48 [3.4]
	Standard housing with diffuser	0.20 [5]	20.75 [528]	4.02 [102]	0.39 [10]						5.01 [128]

*unworked port

**worked port

Dimensions
TRT1, 2, 3, 4

Specifications For The Tank Flange

1. In the filter mounting interface, the tank flange should have a maximum flatness of 0.3 mm and maximum roughness of Ra 3.2 μm .
2. In addition, the mounting interface should be free from damage and scratches.
3. The mounting holes of the flange must be blind, or stud bolts. Loctite must be used to mount the filter. As an alternative, the tank flange can be continuously welded from the inside.
4. Both the tank sheet metal and the filter mounting flange must be sufficiently robust so that neither deform when the seal is compressed during tightening.

TRT1, 2, 3, 4

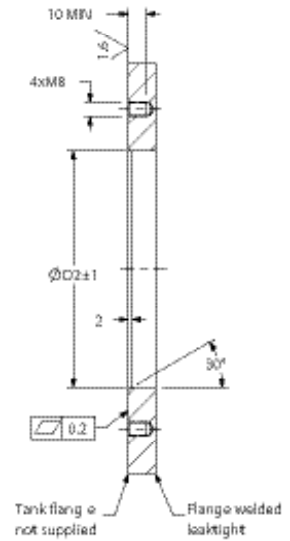
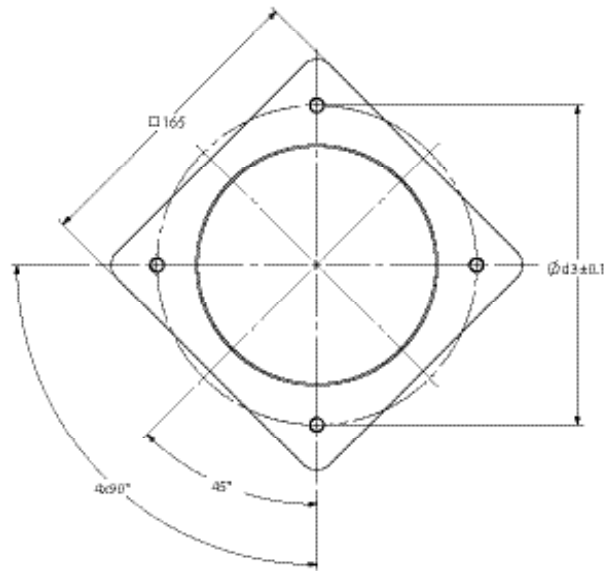

$\Delta P_{\text{element}}$
TRT1

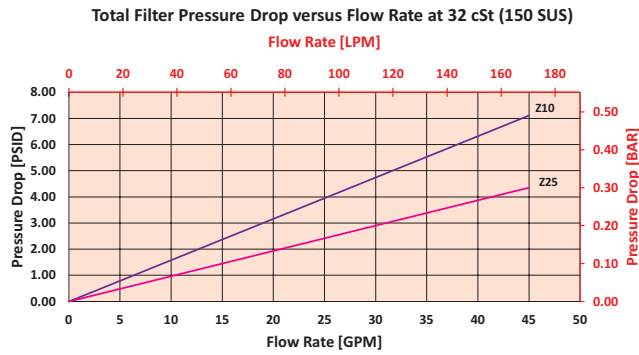

TRT2

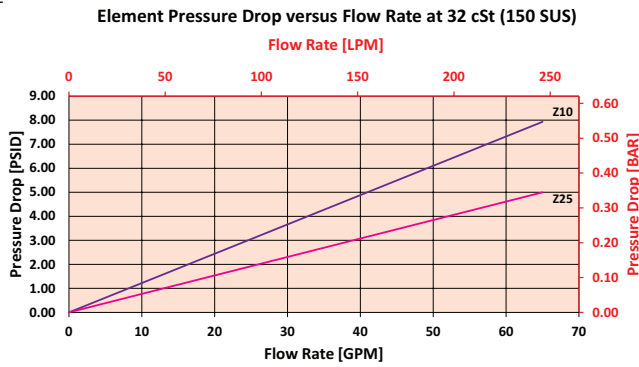

TRT3

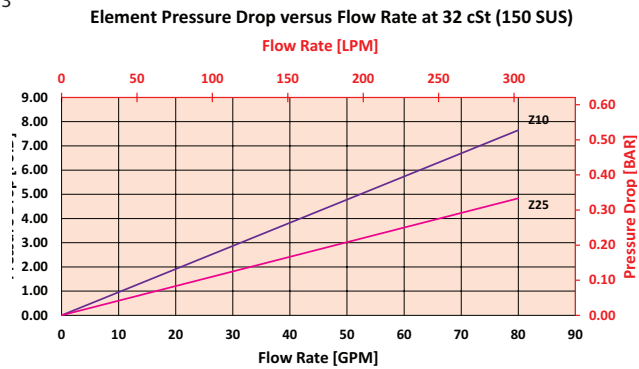

TRT4

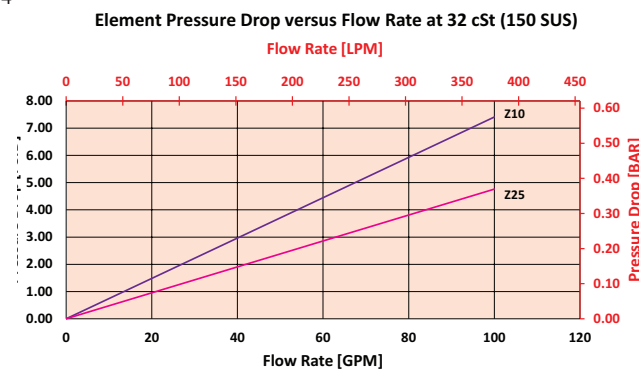

Pressure Drop Information
Based on Flow Rate and Viscosity

Filter Model Number Selection

How to Build a Valid Model Number for a Schroeder TRT:

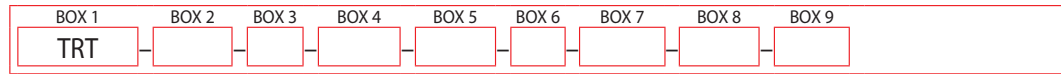

Example: NOTE: One option per box

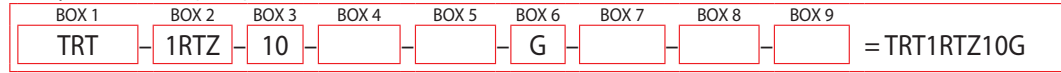

BOX 1	BOX 2	BOX 3	BOX 4
Filter Series	Size of Element	Micron Rating	Bypass
TRT	1RTZ 2RTZ 3RTZ 4RTZ	5 = 5 µm 10 = 10 µm 25 = 25 µm	Omit = standard 36 psi bypass 12 = 12 psi bypass

BOX 5	BOX 6	BOX 7
Magnet	Porting	Housing Option
Omit = no magnetic core M = magnetic core	G = 1-1/2" BSPP S = G 1-1/2" BSPP, SAE DN 40 (1-1/2") SAE-24 (requires BSPP to S24 = SAE bushing to extend port to port dimensions)	Omit = standard housing with diffuser

BOX 8	BOX 9
Seal Material	Dirt Alarm® Options
Omit = Buna N V = Viton®	Omit = No Indicator, sealed up w/ screw plug
Clogging Indicators	VA = visual/electrical
	VE = electrical
	VO = visual

Tank-Mounted Filter

BFT



Features and Benefits

- Low pressure tank-mounted filter
- Designed for high return line flows
- Dual inlet porting options available
- Top, side or bottom mounting
- Optional check valve prevents reservoir siphoning
- Special filter element design provides aftermarket benefits
- Also available with DirtCatcher® element (BBD)
- Cast iron head available

300 gpm
1135 L/min
 100 psi
 7 bar

Model No. of filter in photograph is BFT1BBZ5F.

Flow Rating:	Up to 300 gpm (1135 L/min) for 150 SUS (32 cSt) fluids
Max. Operating Pressure:	100 psi (7 bar)
Min. Yield Pressure:	250 psi (17 bar), per NFPA T2.6.1
Rated Fatigue Pressure:	Contact factory, per NFPA T2.6.1
Temp. Range:	-20°F to 225°F (-29°C to 107°C)
Bypass Setting:	Cracking: 25 psi (1.7 bar) Full Flow: 52 psi (3.6 bar)
Porting Head & Cap:	Aluminum
Element Case:	Steel
Weight of BFT-1BB:	36.7 lbs. (16.6 kg)
Element Change Clearance:	14.75" (375 mm)

Filter Housing Specifications

Type Fluid	Appropriate Schroeder Media
Petroleum Based Fluids	All E media (cellulose) and Z-Media® (synthetic)
High Water Content	All Z-Media® (synthetic)
Invert Emulsions	10 and 25 μ Z-Media® (synthetic)
Water Glycols	3, 5, 10 and 25 μ Z-Media® (synthetic)
Phosphate Esters	All Z-Media® (synthetic) with H (EPR) seal designation
Skydrol®	3, 5, 10 and 25 μ Z-Media® (synthetic) with H.5 seal designation (EPR seals and stainless steel wire mesh in element, and light oil coating on housing exterior)

Fluid Compatibility

Accessories For Tank-Mounted Filters

- IRF
- TF1
- KF3
- KL3
- LF1
- MLF1
- RLD
- GRTB
- MTA
- MTB
- ZT
- AFT
- KFT
- RT
- RTI
- LRT
- ART
- BRT
- TRT
- BFT**
- QT
- KTK
- LTK
- MRT
- PAF1
- MAF1
- MF2

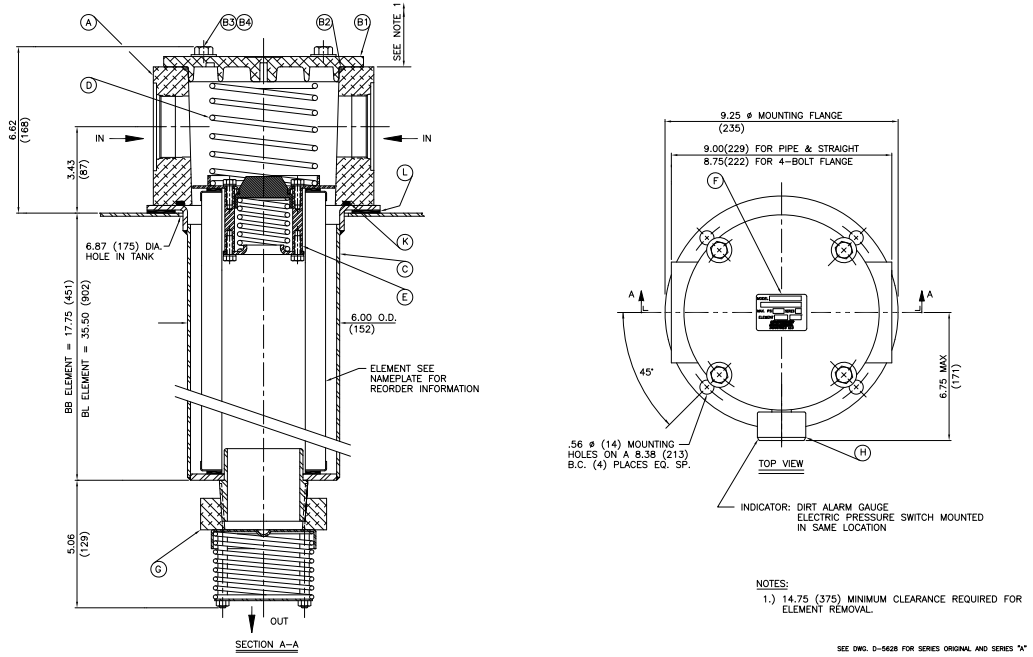

Metric dimensions in ().

Element Performance Information & Dirt Holding Capacity

Element	Filtration Ratio Per ISO 4572/NFPA T3.10.8.8 Using automated particle counter (APC) calibrated per ISO 4402			Filtration Ratio per ISO 16889 Using APC calibrated per ISO 11171	
	$\beta_x \geq 75$	$\beta_x \geq 100$	$\beta_x \geq 200$	$\beta_{x(c)} \geq 200$	$\beta_{x(c)} \geq 1000$
BB/BLZ1	<1.0	<1.0	<1.0	<4.0	4.2
BB/BLZ3	<1.0	<1.0	<2.0	<4.0	4.8
BB/BLZ5	2.5	3.0	4.0	4.8	6.3
BB/BLZ10	7.4	8.2	10.0	8.0	10.0
BB/BLZ25	18.0	20.0	22.5	19.0	24.0

Element	DHC (gm)	Element	DHC (gm)	Element	DHC (gm)
BBZ1	268	BBDZ1	205	BLZ1	536
BBZ3	275	BBDZ3	163	BLZ3	550
BBZ5	301	BBDZ5	229	BLZ5	550
BBZ10	272	BBDZ10	183	BLZ10	550
BBZ25	246	BBDZ25	186	BLZ25	550

Element Collapse Rating: 150 psid (10 bar)

Flow Direction: Outside In

Element Nominal Dimensions: BB: 5.0" (125 mm) O.D. x 18.0" (460 mm) long
BL: 5.0" (125 mm) O.D. x 36.0" (920 mm) long

$\Delta P_{\text{housing}}$

BFT $\Delta P_{\text{housing}}$ for fluids with sp gr (specific gravity) = 0.86:

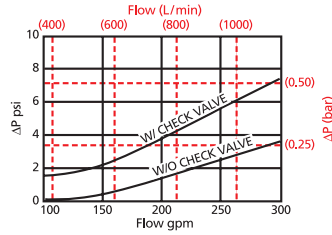

$\Delta P_{\text{element}}$

BBZ

Element Pressure Drop versus Flow Rate at 32 cSt (150 SUS)

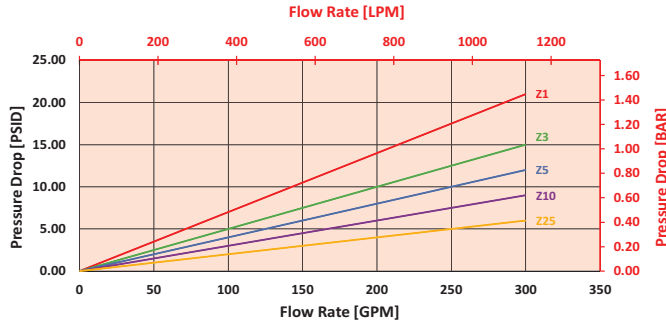

BLZ

Element Pressure Drop versus Flow Rate at 32 cSt (150 SUS)

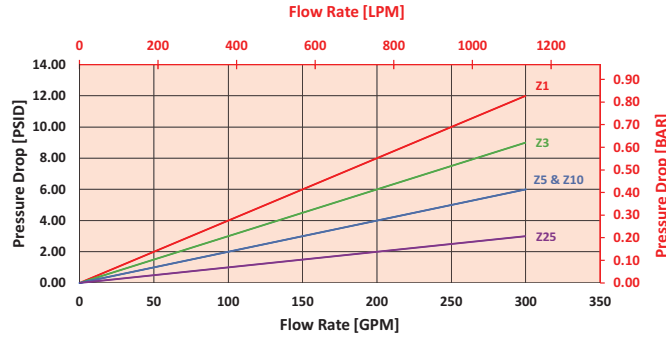

$$\Delta P_{\text{filter}} = \Delta P_{\text{housing}} + (\Delta P_{\text{element}} * V_f)$$

Exercise:

Determine ΔP_{filter} at 200 gpm (758 L/min) for BFT1BBZ10PY2 using 160 SUS (34 cSt) fluid.

Use the housing pressure curve to determine $\Delta P_{\text{housing}}$ at 200 gpm. In this case, $\Delta P_{\text{housing}}$ is 1.5 psi (.10 bar) on the graph for the BFT housing.

Use the element pressure curve to determine $\Delta P_{\text{element}}$ at 200 gpm. In this case, $\Delta P_{\text{element}}$ is 6 psi (.41 bar) according to the graph for the BBZ10 element.

Because the viscosity in this sample is 160 SUS (34 cSt), we determine the Viscosity Factor (V_f) by dividing the Operating Fluid Viscosity with the Standard Viscosity of 150 SUS (32 cSt). To best determine your Operating Fluid Viscosity, please reference the chart in Appendix D.

Finally, the overall filter pressure differential, ΔP_{filter} , is calculated by adding $\Delta P_{\text{housing}}$ with the true element pressure differential, ($\Delta P_{\text{element}} * V_f$). The $\Delta P_{\text{element}}$ from the graph has to be multiplied by the viscosity factor to get the true pressure differential across the element.

Solution:

$\Delta P_{\text{housing}} = 1.5 \text{ psi } [.10 \text{ bar}] \mid \Delta P_{\text{element}} = 6 \text{ psi } [.41 \text{ bar}]$

$V_f = 160 \text{ SUS } (34 \text{ cSt}) / 150 \text{ SUS } (32 \text{ cSt}) = 1.1$

$\Delta P_{\text{filter}} = 1.5 \text{ psi } + (6 \text{ psi } * 1.1) = 8.1 \text{ psi}$

OR

$\Delta P_{\text{filter}} = .10 \text{ bar } + (.41 \text{ bar } * 1.1) = .55 \text{ bar}$

Pressure Drop Information Based on Flow Rate and Viscosity

Note: If your element is not graphed, use the following equation:
 $\Delta P_{\text{element}} = \text{Flow Rate} \times \Delta P_f$ Plug this variable into the overall pressure drop equation.

Ele.	ΔP	Ele.	ΔP
BB10	0.03	BL10	0.01
BB25	0.01	BL25	0.01
BBDZ1	0.08	BLDZ1	0.16
BBDZ3	0.06	BLDZ3	0.12
BBDZ5	0.05	BLDZ5	0.10
BBDZ10	0.04	BLDZ10	0.08
BBDZ25	0.02	BLDZ25	0.04

Filter Model Number Selection

How to Build a Valid Model Number for a Schroeder KF3:

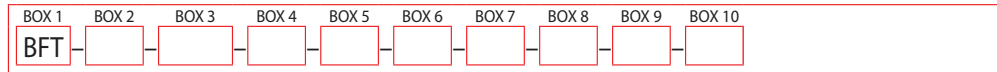

Example: NOTE: Only box 10 may contain more than one option

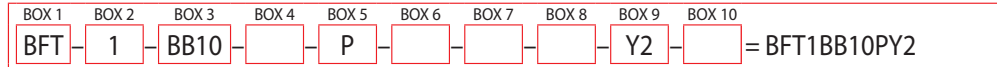

BOX 1	BOX 2	BOX 3				BOX 4
Filter Series	Number of Elements	Element Size and Media				Seal Material
BFT	1	BB Length	BL Length			Omit = Buna N H = EPR = Anodized W Aluminum Parts H.5 = Skydrol® compatibility
		BB3		= 3 μ E media (cellulose)		
		BB10		= 10 μ E media (cellulose)		
		BB25		= 25 μ E media (cellulose)		
		BBZ1	BLZ1	= 1 μ Excellement® Z-Media® (synthetic)		
		BBZ3	BLZ3	= 3 μ Excellement® Z-Media® (synthetic)		
		BBZ5	BLZ5	= 5 μ Excellement® Z-Media® (synthetic)		
		BBZ10	BLZ10	= 10 μ Excellement® Z-Media® (synthetic)		
		BBZ25	BLZ25	= 25 μ Excellement® Z-Media® (synthetic)		
		BBDZ1		= BB size DirtCatcher® 1 μ Excellement® Z-Media®		
		BBDZ3		= BB size DirtCatcher® 3 μ Excellement® Z-Media®		
		BBDZ5		= BB size DirtCatcher® 5 μ Excellement® Z-Media®		
		BBDZ10		= BB size DirtCatcher® 10 μ Excellement® Z-Media®		
		BBDZ25		= BB size DirtCatcher® 25 μ Excellement® Z-Media®		

BOX 5	BOX 6	BOX 7
Porting	Bypass Setting	Outlet Porting
P = 2½" NPTF	Omit = 25 psi cracking	Omit = 3" NPT male
PP = Dual 2½" NPTF	40 = 40 psi cracking	T = 13" Tube extension
S = SAE-32		
SS = Dual SAE-32		
F = 2½"SAE 4-bolt flange Code 61		
FF = Dual 2½"SAE 4-bolt flange Code 61		
	BOX 8	
	Optional Check Valve	
	Omit = None	
	C = Check valve	

BOX 9	BOX 10
Dirt Alarm® Options	Additional Options
Omit = None	Omit = None
Visual Y2 = Back-mounted tri-color gauge	G547 = Two ½" gauge ports
Y2R = Back-mounted gauge mounted on opposite side of standard location	G1476 = Three-terminal electric switch
Electrical ES = Electric switch	M = Metric thread for SAE 4-bolt flange mounting holes (specify after each port designation)
ESR = Electric switch mounted on opposite side of standard location	40 = 40 psi bypass setting
ES1 = Heavy-duty electric switch with conduit connector	
ES1R = Heavy-duty electric switch with conduit connector mounted on opposite side of standard location	
ES2 = Electrical Switch with Deutsch Connector	

NOTES:

Box 3. Replacement element part numbers are identical to contents of Boxes 3 and 4. E media elements are only available with Buna N seals.

Box 4. For options H, W, and H.5 all aluminum parts are anodized. H.5 seal designation includes the following: EPR seals, stainless steel wire mesh on elements, and light oil coating on housing exterior. Skydrol® is a registered trademark of Solutia Inc.

Box 8. See also "Accessories for Tank-Mounted Filters," page 307.

Tank-Mounted Filter

QT



Features and Benefits

- Low pressure tank-mounted filter
- Designed for high return line flows
- Tank-mounted unit saves space, reduces plumbing
- Cap handles provide for easy element changeout
- Offered with standard Q, QW, and QPML deep-pleated elements in 16" and 39" lengths with Viton® seals as the standard seal option

450 gpm
1700 L/min
100 psi
7 bar

Model No. of filter in photograph is QT39QZ10P48D5C.

Flow Rating:	Up to 450 gpm (1700 L/min) for 150 SUS (32 cSt) fluids
Max. Operating Pressure:	100 psi (7 bar)
Min. Yield Pressure:	300 psi (21 bar), per NFPA T2.6.1
Rated Fatigue Pressure:	100 psi (7 bar), per NFPA T2.6.1-R1-2005
Temp. Range:	-20°F to 225°F (-29°C to 107°C)
Bypass Setting:	Cracking: 30 psi (2.1 bar) Full Flow: 55 psi (3.8 bar)
Porting Head:	Steel
Element Case:	Steel
Min. Weight of QT-16Q:	100.0 lbs. (46 kg)
Min. Weight of QT-39Q:	158.0 lbs. (72 kg)
Element Change Clearance:	16Q 12.0" (305 mm) 39Q 33.8" (859 mm)

Filter Housing Specifications

Type Fluid	Appropriate Schroeder Media
Petroleum Based Fluids	All E media (cellulose), Z-Media® and ASP® media (synthetic)
High Water Content	All Z-Media® and ASP® media (synthetic)
Invert Emulsions	10 and 25 µ Z-Media® and 10 µ ASP® media (synthetic)
Water Glycols	3, 5, 10 and 25 µ Z-Media® and all ASP® media (synthetic)
Phosphate Esters	All Z-Media® (synthetic) with H (EPR) seal designation and all ASP® media (synthetic)

Fluid Compatibility

Accessories For Tank-Mounted Filters

- IRF
- TF1
- KF3
- KL3
- LF1
- MLF1
- RLD
- GRTB
- MTA
- MTB
- ZT
- AFT
- KFT
- RT
- RTI
- LRT
- ART
- BRT
- TRT
- BFT
- QT**
- KTK
- LTK
- MRT
- PAF1
- MAF1
- MF2

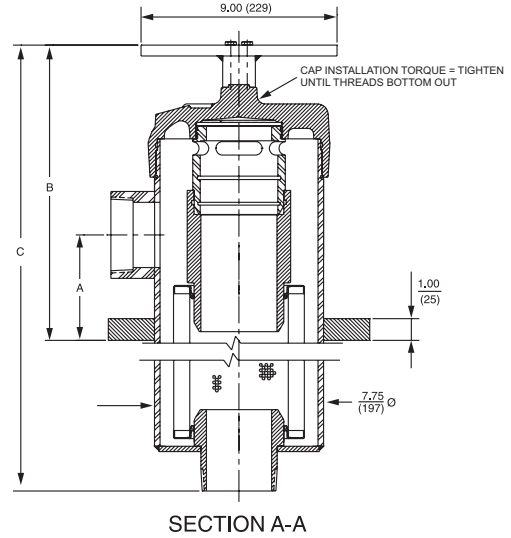
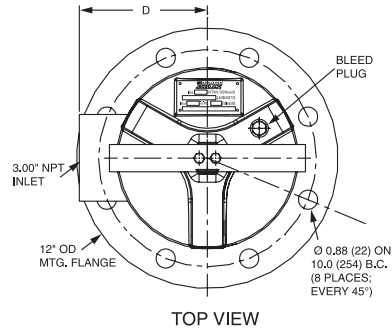

INLET PORT SIZE*	DIMENSIONS			
	A	B	C	D
3"	4.85	14.62	16Q: 30.43 (773)	5.88
	(123)	(371)	39Q: 52.25 (1327)	(149)
4"	5.75	16.12	16Q: 30.43 (773)	6.13
	(146)	(409)	39Q: 52.25 (1327)	(156)

*Outlet port is always 3".

Metric dimensions in ().

Element Performance Information & Dirt Holding Capacity

Element	Filtration Ratio Per ISO 4572/NFPA T3.10.8.8 Using automated particle counter (APC) calibrated per ISO 4402			Filtration Ratio per ISO 16889 Using APC calibrated per ISO 11171		
	$\beta_x \geq 75$	$\beta_x \geq 100$	$\beta_x \geq 200$	$\beta_x(c) \geq 200$	$\beta_x(c) \geq 1000$	
16Q	Z1/PMLZ1	<1.0	<1.0	<1.0	<4.0	4.2
	Z3/PMLZ3	<1.0	<1.0	<2.0	<4.0	4.8
	Z5/PMLZ5	2.5	3.0	4.0	4.8	6.3
	Z10/PMLZ10	7.4	8.2	10.0	8.0	10.0
	Z25/PMLZ25	18.0	20.0	22.5	19.0	24.0
39Q	Z1/PMLZ1	<1.0	<1.0	<1.0	<4.0	4.2
	Z3/PMLZ3	<1.0	<1.0	<2.0	<4.0	4.8
	Z5/PMLZ5	2.5	3.0	4.0	4.8	6.3
	Z10/PMLZ10	7.4	8.2	10.0	8.0	10.0
	Z25/PMLZ25	18.0	20.0	22.5	19.0	24.0

Element	DHC (gm)	Element	DHC (gm)
16Q	Z1	PMLZ1	307
	Z3	PMLZ3	315
	Z5	PMLZ5	364
	Z10	PMLZ10	330
	Z25	PMLZ25	299
39Q	Z1	PMLZ1	1485
	Z3	PMLZ3	1525
	Z5	PMLZ5	1235
	Z10	PMLZ10	1432
	Z25	PMLZ25	1299

Element Collapse Rating: Q and QPML: 150 psid (10 bar)

Flow Direction: Outside In

Element Nominal Dimensions: 16Q: 6.0" (150 mm) O.D. x 16.85" (430 mm) long
 16QPML: 6.0" (150 mm) O.D. x 16.00" (405 mm) long
 39Q: 6.0" (150 mm) O.D. x 38.70" (985 mm) long
 39QPML: 6.0" (150 mm) O.D. x 37.80" (960 mm) long

$\Delta P_{\text{housing}}$

QT $\Delta P_{\text{housing}}$ for fluids with sp gr (specific gravity) = 0.86:

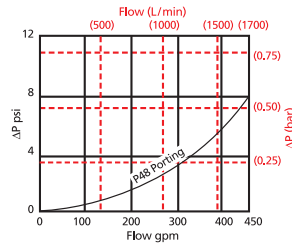

$\Delta P_{\text{element}}$

39QZ Element Pressure Drop versus Flow Rate at 32 cSt (150 SUS)

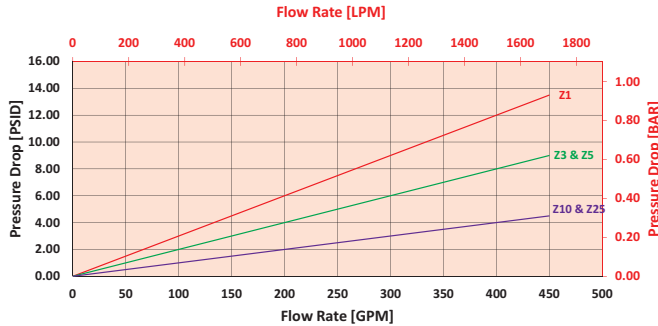

39QPMLZ Element Pressure Drop versus Flow Rate at 32 cSt (150 SUS)

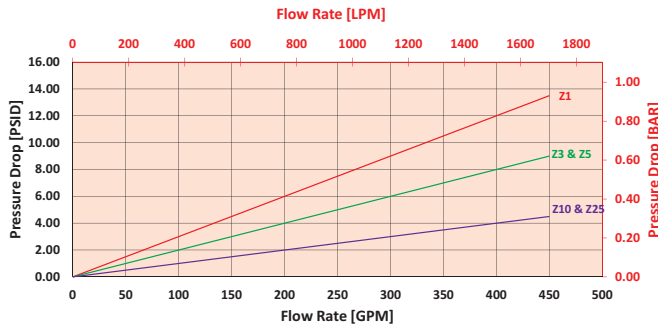

$$\Delta P_{\text{filter}} = \Delta P_{\text{housing}} + (\Delta P_{\text{element}} * V_f)$$

Exercise:

Determine ΔP_{filter} at 200 gpm (758 L/min) for QT16QZ3P48D5C using 160 SUS (34 cSt) fluid.

Use the housing pressure curve to determine $\Delta P_{\text{housing}}$ at 200 gpm. In this case, $\Delta P_{\text{housing}}$ is 2 psi (.14 bar) on the graph for the QT housing.

Use the element pressure curve to determine $\Delta P_{\text{element}}$ at 200 gpm. In this case, $\Delta P_{\text{element}}$ is 8 psi (.55 bar) according to the graph for the 16QZ3 element.

Because the viscosity in this sample is 160 SUS (34 cSt), we determine the Viscosity Factor (V_f) by dividing the Operating Fluid Viscosity with the Standard Viscosity of 150 SUS (32 cSt). To best determine your Operating Fluid Viscosity, please reference the chart in Appendix D.

Finally, the overall filter pressure differential, ΔP_{filter} , is calculated by adding $\Delta P_{\text{housing}}$ with the true element pressure differential, ($\Delta P_{\text{element}} * V_f$). The $\Delta P_{\text{element}}$ from the graph has to be multiplied by the viscosity factor to get the true pressure differential across the element.

Solution:

$$\Delta P_{\text{housing}} = 2 \text{ psi } [.14 \text{ bar}] \mid \Delta P_{\text{element}} = 8 \text{ psi } [.55 \text{ bar}]$$

$$V_f = 160 \text{ SUS } (34 \text{ cSt}) / 150 \text{ SUS } (32 \text{ cSt}) = 1.1$$

$$\Delta P_{\text{filter}} = 2 \text{ psi } + (8 \text{ psi } * 1.1) = 10.8 \text{ psi}$$

OR

$$\Delta P_{\text{filter}} = .14 \text{ bar } + (.55 \text{ bar } * 1.1) = .75 \text{ bar}$$

Pressure Drop Information Based on Flow Rate and Viscosity

Note: If your element is not graphed, use the following equation:
 $\Delta P_{\text{element}} = \text{Flow Rate} \times \Delta P_f$ Plug this variable into the overall pressure drop equation.

Ele.	ΔP	Ele.	ΔP
16QAS3V	0.04	16QPMLZ1	0.08
16QAS5V	0.04	16QPMLZ3	0.05
16QAS10V	0.03	16QPMLZ5	0.05
16QPMLAS3V	0.05	16QPMLZ10	0.04
16QPMLAS5V	0.05	16QPMLZ25	0.02
16QPMLAS10V	0.04	39QAS3V	0.01
16QZ1	0.09	39QAS5V	0.01
16QZ3	0.04	39QAS10V	0.01
16QZ5	0.04	39QPMLAS3V	0.02
16QZ10	0.03	39QPMLAS5V	0.02
16QZ25	0.01	39QPMLAS10V	0.01

Filter Model Number Selection

How to Build a Valid Model Number for a Schroeder QT:

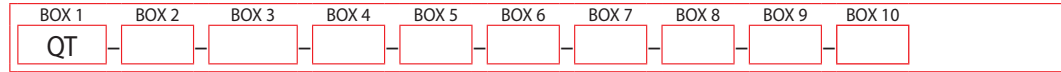

Example: NOTE: One option per box

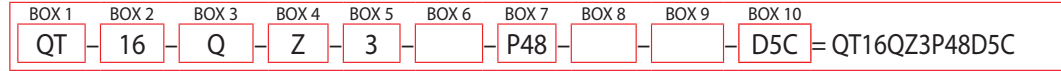

BOX 1	BOX 2	BOX 3	BOX 4	BOX 5	BOX 6
Filter Series	Element Length (in)	Element Style	Media Type	Micron Rating	Housing Seal Material
QT	16 39	Q QCLQF QPML	Z = Excellement® Z-Media® (synthetic) W = W media (water removal) AS = Anti-Static Pleat Media (synthetic)	1 = 1 μ Z-Media® 3 = 3 μ AS and Z-Media® 5 = 5 μ AS and Z-Media® 10 = 10 μ AS and Z-Media® 25 = 25 μ Z-Media®	Omit = Buna N H = EPR V = Viton®

BOX 7

Inlet Porting
P48 = 3" NPTF P64 = 4" NPTF

BOX 8

Bypass Setting
Omit = 30 psi cracking X = Blocked bypass 50 = 50 psi cracking

BOX 9

Outlet Porting
Omit = 3" NPT Male C = Check valve D = Diffuser CD = Check valve and diffuser

BOX 10

Dirt Alarm® Options	
	Omit = None
Visual	D5C = Visual pop-up in cap
Visual with Thermal Lockout	D8C = Visual w/ thermal lockout in cap
Electrical	MS5C = Electrical w/ 12 in. 18 gauge 4-conductor cable in cap MS5LCC = Low current MS5 in cap MS10C = Electrical w/ DIN connector (male end only) in cap MS10LCC = Low current MS10 in cap MS11C = Electrical w/ 12 ft. 4-conductor wire in cap MS12C = Electrical w/ 5 pin Brad Harrison connector (male end only) in cap MS12LCC = Low current MS12 in cap MS16C = Electrical w/ weather-packed sealed connector in cap MS16LCC = Low current MS16 in cap MS17LCC = Electrical w/ 4 pin Brad Harrison male connector in cap
Electrical with Thermal Lockout	MS5T = MS5 (see above) w/ thermal lockout in cap MS5LCT = Low current MS5T in cap MS10TC = MS10 (see above) w/ thermal lockout in cap MS10LCTC = Low current MS10T in cap MS12TC = MS12 (see above) w/ thermal lockout MS12LCTC = Low current MS12T in cap MS16TC = MS16 (see above) w/ thermal lockout in cap MS16LCTC = Low current MS16T in cap MS17LCTC = Low current MS17T in cap
Electrical Visual	MS13C = Supplied w/ threaded connector & light in cap MS14C = Supplied w/ 5 pin Brad Harrison connector & light (male end) in cap
Electrical Visual with Thermal Lockout	MS13DCTC = MS13 (see above), direct current, w/ thermal lockout in cap MS13DCLCTC = Low current MS13DCT in cap MS14DCTC = MS14 (see above), direct current, w/ thermal lockout in cap MS14DCLCTC = Low current MS14DCT in cap

NOTES:

Box 2. Replacement element part numbers are a combination of Boxes 2, 3, 4 and 5, plus the letter V. Example: 16QZ1V

Box 3. QCLQF element are not available in ASP® media.

Box 4. E media elements are also available for the QT filter housing. Contact factory for more information.

Box 4. For Option W, Box 3 must equal Q.

Box 6. Viton® is a registered trademark of DuPont Dow Elastomers. All elements for this filter are supplied with Viton® seals. Seal designation in Box 6 applies to housing only.

Tank-Mounted Filter Kit

KTK



Features and Benefits

- Special tank-mounted filter kit
- Includes: cap assembly, weld ring assembly, element and bushing
- Available with standard K, KK or 27K-size elements
- Bypass valve in cap assembly

100 gpm
380 L/min
 100 psi
7 bar

Model No. of filter in photograph is KTKKKZ10.

Flow Rating:	Up to 100 gpm (380 L/min) for 150 SUS (32 cSt) fluids
Max. Operating Pressure:	100 psi (7 bar) exclusive of tank design
Min. Yield Pressure:	Contact factory
Rated Fatigue Pressure:	Contact factory
Temp. Range:	-20°F to 225°F (-29°C to 107°C)
Bypass Setting:	Cracking: 25 psi (1.7 bar) Full Flow: 40 psi (2.8 bar)
Porting Cap:	Die Cast Aluminum
Weld Ring:	Steel
Element Change Clearance:	8.0" (205 mm) for K; 17.50" (445 mm) for KK; 26.5" (673 mm) for 27K

Filter Housing Specifications

Type Fluid	Appropriate Schroeder Media
Petroleum Based Fluids	All E media (cellulose), Z-Media [®] and ASP [®] media (synthetic)
High Water Content	All Z-Media [®] and all ASP [®] media (synthetic)
Invert Emulsions	10 and 25 μ Z-Media [®] and 10 μ ASP [®] media (synthetic)
Water Glycols	3, 5, 10 and 25 μ Z-Media [®] and all ASP [®] media (synthetic)
Phosphate Esters	All Z-Media [®] (synthetic) with H (EPR) seal designation and 3 and 10 μ E media (cellulose) with H (EPR) seal designation and ASP [®] media (synthetic)
Skydrol [®]	3, 5, 10 and 25 μ Z-Media [®] (synthetic) with H.5 seal designation (EPR seals and stainless steel wire mesh in element, and light oil coating on housing exterior) and all ASP [®] media (synthetic)

Fluid Compatibility

Accessories For Tank-Mounted Filters

- IRF
- TF1
- KF3
- KL3
- LF1
- MLF1
- RLD
- GRTB
- MTA
- MTB
- ZT
- AFT
- KFT
- RT
- RTI
- LRT
- ART
- BRT
- TRT
- BFT
- QT
- KTK**
- LTK
- MRT
- PAF1
- MAF1
- MF2

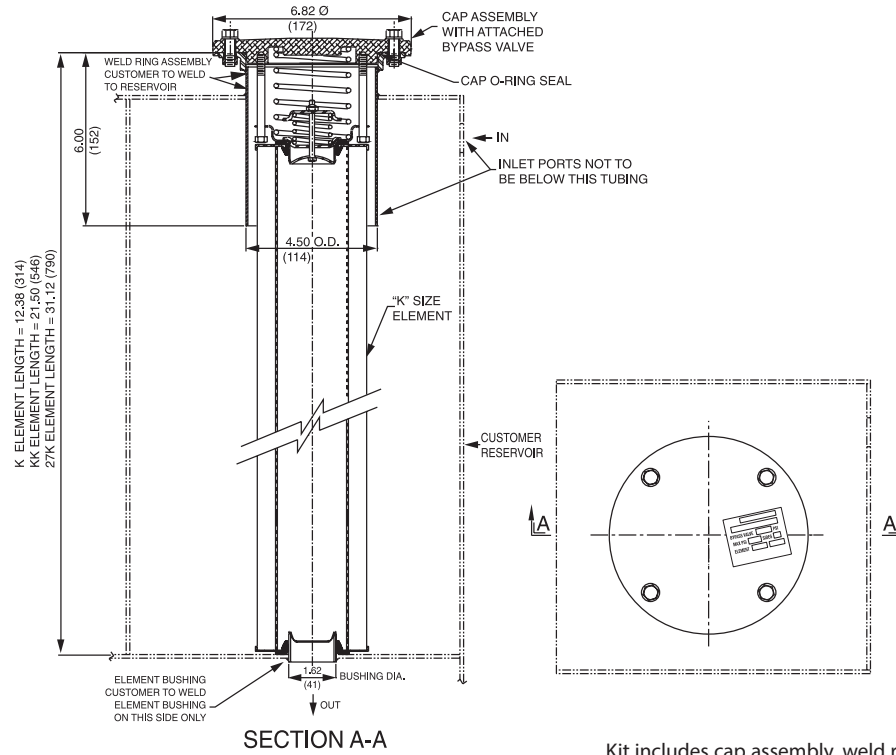

Metric dimensions in ().

Kit includes cap assembly, weld ring assembly, element, and bushing.

Element Performance Information & Dirt Holding Capacity

Element	Filtration Ratio Per ISO 4572/NFPA T3.10.8.8 Using automated particle counter (APC) calibrated per ISO 4402			Filtration Ratio per ISO 16889 Using APC calibrated per ISO 11171	
	$\beta_x \geq 75$	$\beta_x \geq 100$	$\beta_x \geq 200$	$\beta_x(c) \geq 200$	$\beta_x(c) \geq 1000$
KZ1	<1.0	<1.0	<1.0	<4.0	4.2
KZ3	<1.0	<1.0	<2.0	<4.0	4.8
KZ5	2.5	3.0	4.0	4.8	6.3
KZ10	7.4	8.2	10.0	8.0	10.0
KZ25	18.0	20.0	22.5	19.0	24.0
KZW1	N/A	N/A	N/A	<4.0	<4.0
KZW3/KKZW3	N/A	N/A	N/A	4.0	4.8
KZW5/KKZW5	N/A	N/A	N/A	5.1	6.4
KZW10/KKZW10	N/A	N/A	N/A	6.9	8.6
KZW25/KKZW25	N/A	N/A	N/A	15.4	18.5

Element	DHC (gm)	Element	DHC (gm)	Element	DHC (gm)	Element	DHC (gm)	Element	DHC (gm)
KZ1	112	KKZ1	224	27KZ1	336	KZW1	61		
KZ3	115	KKZ3	230	27KZ3	345	KZW3	64	KKZW3	128
KZ5	119	KKZ5	238	27KZ5	357	KZW5	63	KKZW5	126
KZ10	108	KKZ10	216	27KZ10	324	KZW10	57	KKZW10	114
KZ25	93	KKZ25	186	27KZ25	279	KZW25	79	KKZW25	158

Element Collapse Rating: 150 psid (10 bar) for standard elements

Flow Direction: Outside In

Element Nominal Dimensions: 3.9" (99 mm) O.D. x 9.0" (230 mm) long

Pressure Drop Information
Based on Flow Rate and Viscosity

*KTK Dirty Box Pressure Drop is Customer Tank Design Dependant. Please account for this when designing system.

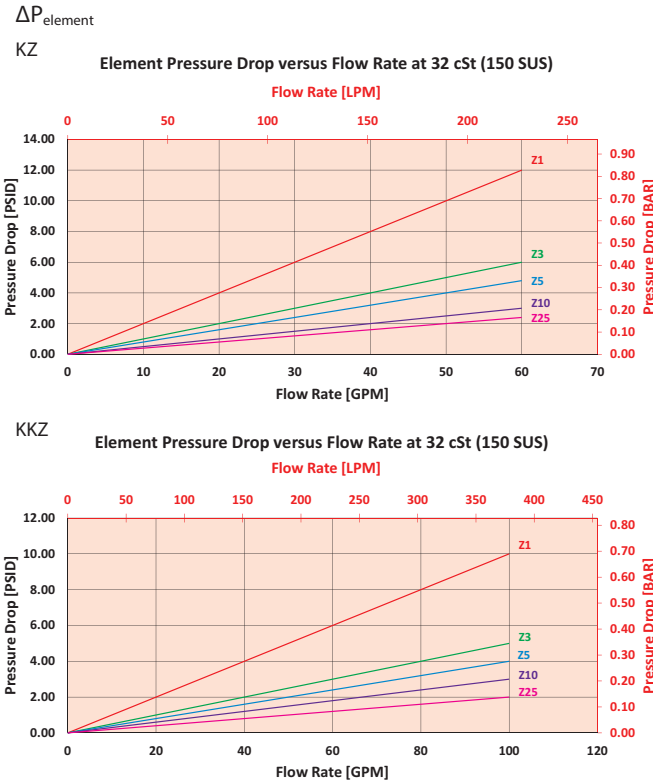

$$\Delta P_{\text{filter}} = \Delta P_{\text{housing}} + (\Delta P_{\text{element}} * V_f)$$

Exercise:

Determine ΔP_{filter} at 80 gpm (303.2 L/min) for KTKKZ3 using 160 SUS (34 cSt) fluid.

Use the element pressure curve to determine $\Delta P_{\text{element}}$ at 80 gpm. In this case, $\Delta P_{\text{element}}$ is 8 psi (.55 bar) according to the graph for the KZ3 element.

Because the viscosity in this sample is 160 SUS (34 cSt), we determine the Viscosity Factor (V_f) by dividing the Operating Fluid Viscosity with the Standard Viscosity of 150 SUS (32 cSt). To best determine your Operating Fluid Viscosity, please reference the chart in Appendix D.

Finally, the overall filter pressure differential, ΔP_{filter} , is calculated by adding $\Delta P_{\text{housing}}$ with the true element pressure differential, ($\Delta P_{\text{element}} * V_f$). The $\Delta P_{\text{element}}$ from the graph has to be multiplied by the viscosity factor to get the true pressure differential across the element.

Solution:

$$\Delta P_{\text{element}} = 8 \text{ psi } [.55 \text{ bar}]$$

$$V_f = 160 \text{ SUS (34 cSt)} / 150 \text{ SUS (32 cSt)} = 1.1$$

$$\Delta P_{\text{filter}} = (8 \text{ psi} * 1.1) = 8.8 \text{ psi}$$

OR

$$\Delta P_{\text{filter}} = (.55 \text{ bar} * 1.1) = .61 \text{ bar}$$

Note:

If your element is not graphed, use the following equation:

$\Delta P_{\text{element}} = \text{Flow Rate} \times \Delta P_f$. Plug this variable into the overall pressure drop equation.

Ele.	ΔP	Ele.	ΔP	Ele.	ΔP
K3	0.25	2K3/ KK3	0.12	3KZ1/ 27KZ1	0.05
K10	0.09	2K10/ KK10	0.05	3KZ3/ 27KZ3	0.03
K25	0.02	2K25/ KK25	0.01	3KZ5/ 27KZ5	0.02
KAS3	0.10	2KAS3/ KKAS3	0.05	3KZ10/ 27KZ10	0.02
KAS5	0.08	2KAS5/ KKAS5	0.04	3KZ25/ 27KZ25	0.01
KAS10	0.05	2KAS10/ KKAS10	0.03	3K3	0.08
KZW1	0.43	2KZW1	-	3K10	0.03
KZW3	0.32	2KZW3/ KKZW3	0.16	3K25	0.01
KZW5	0.28	2KZW5/ KKZW5	0.14	3KAS3/ 27KAS3	0.03
KZW10	0.23	2KZW10/ KKZW10	0.12	3KAS5/ 27KAS5	0.02
KZW25	0.14	2KZW25/ KKZW25	0.07	3KAS10/ 27KAS10	0.02

Filter Model Number Selection

How to Build a Valid Model Number for a Schroeder KTK:

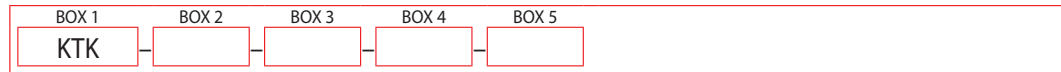

Example: NOTE: One option per box

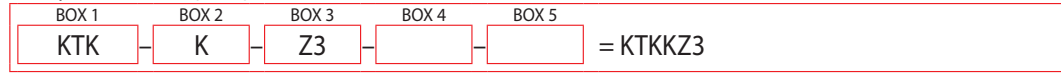

BOX 1	BOX 2	BOX 3
Filter Series	Element Length	Element Part Number
KTK	K KK 27K	3 = 3 μ E media (cellulose) 10 = 10 μ E media (cellulose) 25 = 25 μ E media (cellulose) Z1 = 1 μ Excellement® Z-Media® (synthetic) Z3/AS3 = 3 μ Excellement® Z-Media® (synthetic) Z5/AS5 = 5 μ Excellement® Z-Media® (synthetic) Z10/AS10 = 10 μ Excellement® Z-Media® (synthetic) Z25 = 25 μ Excellement® Z-Media® (synthetic) ZW1 = 1 μ Aqua-Excellement™ ZW media ZW3 = 3 μ Aqua-Excellement™ ZW media ZW5 = 5 μ Aqua-Excellement™ ZW media ZW10 = 10 μ Aqua-Excellement™ ZW media ZW25 = 25 μ Aqua-Excellement™ ZW media ZW1 = 1 μ Aqua-Excellement™ ZW media ZW3 = 3 μ Aqua-Excellement™ ZW media ZW5 = 5 μ Aqua-Excellement™ ZW media ZW10 = 10 μ Aqua-Excellement™ ZW media ZW25 = 25 μ Aqua-Excellement™ ZW media

BOX 4	BOX 5
Seal Material	Dirt Alarm® Options
Omit = Buna N H = EPR W = Buna N H.5 = Skydrol® Compatibility	Omit = None Visual Y2C = Bottom-mounted gauge in cap

NOTES:

Box 3. Replacement element part numbers are identical to contents of Boxes 2, 3, and 4.

Box 4. For options H and W, cap is anodized. H.5 seal designation includes the following: EPR seals, stainless steel wire mesh on elements, and light oil coating on housing exterior. Skydrol® is a registered trademark of Solutia Inc.

Tank-Mounted Filter Kit

LTK



Features and Benefits

- Special tank-mounted filter kit
- Includes: cap assembly, weld ring assembly, element and bushing
- Available with standard 18L sized element
- Bypass valve in cap assembly

150 gpm
570 L/min
100 psi
7 bar

Model No. of filter in photograph is LTK18LZ3.

Flow Rating:	Up to 150 gpm (570 L/min) for 150 SUS (32 cSt) fluids
Max. Operating Pressure:	100 psi (7 bar) exclusive of tank design
Min. Yield Pressure:	Contact factory
Rated Fatigue Pressure:	Contact factory
Temp. Range:	-20°F to 225°F (-29°C to 107°C)
Bypass Setting:	Cracking: 25 psi (1.7 bar) Full Flow: 47 psi (3.2 bar)
Porting Cap:	Die Cast Aluminum
Weld Ring:	Steel
Element Change Clearance:	17.0" (435 mm)

Filter Housing Specifications

Type Fluid	Appropriate Schroeder Media
Petroleum Based Fluids	All E media (cellulose) and Z-Media* (synthetic)
High Water Content	All Z-Media* (synthetic)
Invert Emulsions	10 and 25 μ Z-Media* (synthetic)
Water Glycols	3, 5, 10 and 25 μ Z-Media* (synthetic)
Phosphate Esters	All Z-Media* (synthetic) with H (EPR) seal designation and 3 and 10 μ E media (cellulose) with H (EPR) seal designation
Skydrol*	3, 5, 10 and 25 μ Z-Media* (synthetic) with H.5 seal designation (EPR seals and stainless steel wire mesh in element, and light oil coating on housing exterior)

Fluid Compatibility

Accessories For Tank-Mounted Filters

- IRF
- TF1
- KF3
- KL3
- LF1
- MLF1
- RLD
- GRTB
- MTA
- MTB
- ZT
- AFT
- KFT
- RT
- RTI
- LRT
- ART
- BRT
- TRT
- BFT
- QT
- KTK
- LTK**
- MRT
- PAF1
- MAF1
- MF2

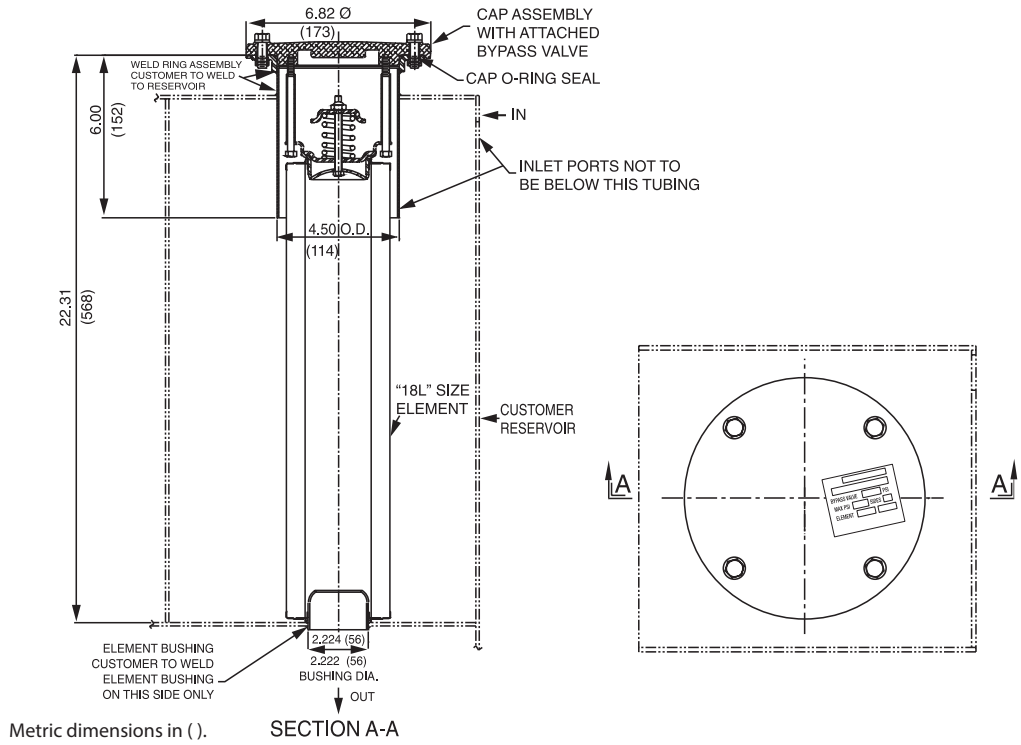

Element Performance Information & Dirt Holding Capacity

Element	Filtration Ratio Per ISO 4572/NFPA T3.10.8.8 Using automated particle counter (APC) calibrated per ISO 4402			Filtration Ratio per ISO 16889 Using APC calibrated per ISO 11171	
	$\beta_x \geq 75$	$\beta_x \geq 100$	$\beta_x \geq 200$	$\beta_x(c) \geq 200$	$\beta_x(c) \geq 1000$
18LZ1	<1.0	<1.0	<1.0	<4.0	4.2
18LZ3	<1.0	<1.0	<2.0	<4.0	4.8
18LZ5	2.5	3.0	4.0	4.8	6.3
18LZ10	7.4	8.2	10.0	8.0	10.0
18LZ25	18.0	20.0	22.5	19.0	24.0

Element	DHC (gm)
18LZ1	224
18LZ3	230
18LZ5	238
18LZ10	216
18LZ25	186

Element Collapse Rating: 150 psid (10 bar)
 Flow Direction: Outside In
 Element Nominal Dimensions: 4.0" (100 mm) O.D. x 18.5" (470 mm) long

*LTK Dirty Box Pressure Drop is Customer Tank Design Dependant. Please account for this when designing system.

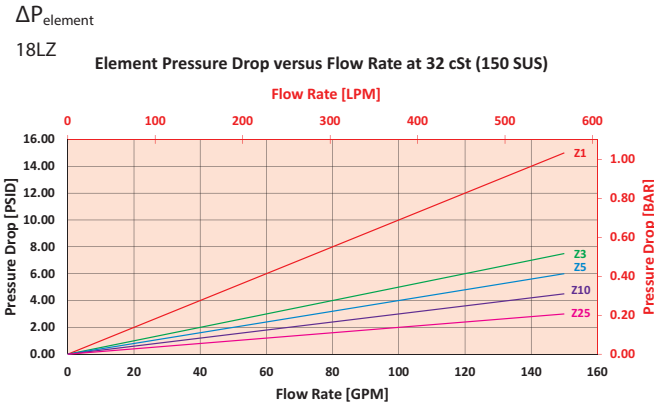

$$\Delta P_{\text{filter}} = \Delta P_{\text{housing}} + (\Delta P_{\text{element}} * V_f)$$

Exercise:

Determine ΔP_{filter} at 80 gpm (303.2 L/min) for LTK18LKZ3 using 160 SUS (34 cSt) fluid.

Use the element pressure curve to determine $\Delta P_{\text{element}}$ at 80 gpm. In this case, $\Delta P_{\text{element}}$ is 4 psi (.27 bar) according to the graph for the 18LZ3 element.

Because the viscosity in this sample is 160 SUS (34 cSt), we determine the Viscosity Factor (V_f) by dividing the Operating Fluid Viscosity with the Standard Viscosity of 150 SUS (32 cSt). To best determine your Operating Fluid Viscosity, please reference the chart in Appendix D.

Finally, the overall filter pressure differential, ΔP_{filter} , is calculated by adding $\Delta P_{\text{housing}}$ with the true element pressure differential, ($\Delta P_{\text{element}} * V_f$). The $\Delta P_{\text{element}}$ from the graph has to be multiplied by the viscosity factor to get the true pressure differential across the element.

Solution:

$$\Delta P_{\text{element}} = 4 \text{ psi } [.27 \text{ bar}]$$

$$V_f = 160 \text{ SUS (34 cSt) } / 150 \text{ SUS (32 cSt) } = 1.1$$

$$\Delta P_{\text{filter}} = (4 \text{ psi} * 1.1) = 4.4 \text{ psi}$$

OR

$$\Delta P_{\text{filter}} = (.27 \text{ bar} * 1.1) = .30 \text{ bar}$$

Filter Model Number Selection

How to Build a Valid Model Number for a Schroeder LTK:

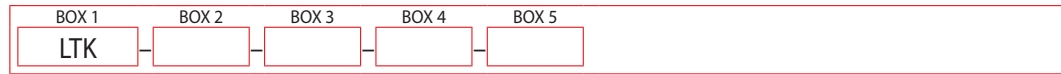

Example: NOTE: One option per box

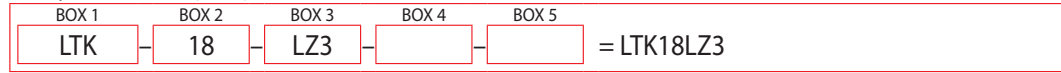

BOX 1	BOX 2	BOX 3	BOX 4
Filter Series	Length of Element (in)	Element Size and Media	Seal Material
LTK	18	L3 = L size 3 μ E media (cellulose) L10 = L size 10 μ E media (cellulose) L25 = L size 25 μ E media (cellulose) LZ1 = L size 1 μ Excellement [®] Z-Media [®] (synthetic) LZ3 = L size 3 μ Excellement [®] Z-Media [®] (synthetic) LZ5 = L size 5 μ Excellement [®] Z-Media [®] (synthetic) LZ10 = L size 10 μ Excellement [®] Z-Media [®] (synthetic) LZ25 = L size 25 μ Excellement [®] Z-Media [®] (synthetic)	Omit = Buna N H = EPR W = Buna N H.5 = Skydrol [®] Compatibility

BOX 5	
Dirt Alarm [®] Options	
Omit	= None
Visual	Y2C = Bottom-mounted gauge in cap

NOTES:

Box 2. Replacement element part numbers are a combination of Boxes 2, 3, and 4.
Example: 18LZ3H

Box 4. For options H and W, cap is anodized.
H.5 seal designation includes the following:
EPR seals, stainless steel wire mesh on elements, and light oil coating on housing exterior.
Skydrol[®] is a registered trademark of Solutia Inc.

Medium Pressure In-Tank Filter

MRT



Features and Benefits

- Medium pressure tank mounted filter ideal for applications with high pressure surge in the return line
- Two possible inlet porting locations
- Various Dirt Alarm® options available
- Also available with DirtCatcher® element
- Optional sampling fitting available upon request

150 gpm
570 L/min
 900 psi
62 bar

Model No. of filter in photograph is MRT18LZ10S24S24D5.

Flow Rating:	Up to 150 gpm (570 L/min) for 150 SUS (32 cSt) fluids
Max. Operating Pressure:	900 psi (62 bar)
Min. Yield Pressure:	2700 psi (186 bar), per NFPA T2.6.1
Rated Fatigue Pressure:	750 psi (52 bar), per NFPA T2.6.1-2005
Temp. Range:	-20°F to 225°F (-29°C to 107°C)
Bypass Setting:	Cracking: 40 psi (2.8 bar)
Porting Head & Cap:	Cast Aluminum (Anodized)
Element Case:	Steel
Weight of MRT:	36.0 lbs. (16.4 kg)
Element Change Clearance:	17.0" (432 mm)

Filter Housing Specifications

Type Fluid	Appropriate Schroeder Media
Petroleum Based Fluids	All E media (cellulose) and Z-Media® (synthetic)
High Water Content	All Z-Media® (synthetic)
Invert Emulsions	10 and 25 μ Z-Media® (synthetic)
Water Glycols	3, 5, 10 and 25 μ Z-Media® (synthetic)

Fluid Compatibility

- IRF
- TF1
- KF3
- KL3
- LF1
- MLF1
- RLD
- GRTB
- MTA
- MTB
- ZT
- AFT
- KFT
- RT
- RTI
- LRT
- ART
- BRT
- TRT
- BFT
- QT
- KTK
- LTK
- MRT**
- Accessories For Tank-Mounted Filters
- PAF1
- MAF1
- MF2

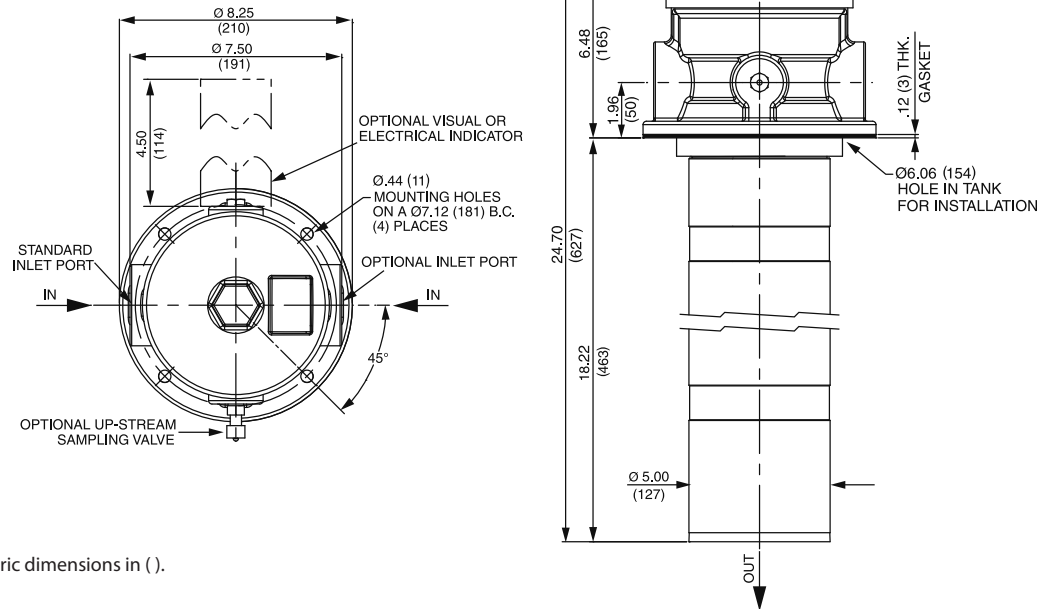

Metric dimensions in ().

Element Performance Information & Dirt Holding Capacity

Element	Filtration Ratio Per ISO 4572/NFPA T3.10.8.8 Using automated particle counter (APC) calibrated per ISO 4402			Filtration Ratio per ISO 16889 Using APC calibrated per ISO 11171	
	$\beta_x \geq 75$	$\beta_x \geq 100$	$\beta_x \geq 200$	$\beta_{x(c)} \geq 200$	$\beta_{x(c)} \geq 1000$
18LZ1	<1.0	<1.0	<1.0	<4.0	4.2
18LZ3	<1.0	<1.0	<2.0	<4.7	5.8
18LZ5	2.5	3.0	4.0	6.5	7.5
18LZ10	7.4	8.2	10.0	10.0	12.7
18LZ25	18.0	20.0	22.5	19.0	24.0
18LDZ1	<1.0	<1.0	<1.0	<4.0	4.2
18LDZ3	<1.0	<1.0	<2.0	<4.7	5.8
18LDZ5	2.5	3.0	4.0	6.5	7.5
18LDZ10	7.4	8.2	10.0	10.0	12.7
18LDZ25	18.0	20.0	22.5	19.0	24.0

Element	DHC (gm)	Element	DHC (gm)
18LZ1	224	18LDZ1	194
18LZ3	230	18LDZ3	199
18LZ5	238	18LDZ5	149
18LZ10	216	18LDZ10	186
18LZ25	186	18LDZ25	169

Element Collapse Rating: 150 psid (10 bar)
 Flow Direction: Outside In
 Element Nominal Dimensions: 4.0" (100 mm) O.D. x 18.5" (470 mm) long

$\Delta P_{\text{housing}}$

MRT $\Delta P_{\text{housing}}$ for fluids with sp gr (specific gravity) = 0.86:

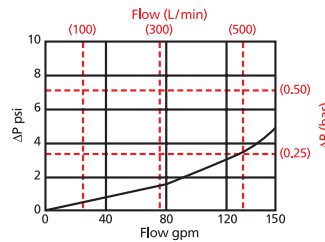

$\Delta P_{\text{element}}$

18LZ Element Pressure Drop versus Flow Rate at 32 cSt (150 SUS)

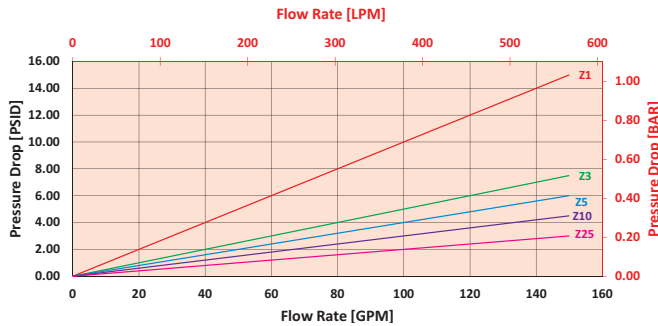

18LDZ Element Pressure Drop versus Flow Rate at 32 cSt (150 SUS)

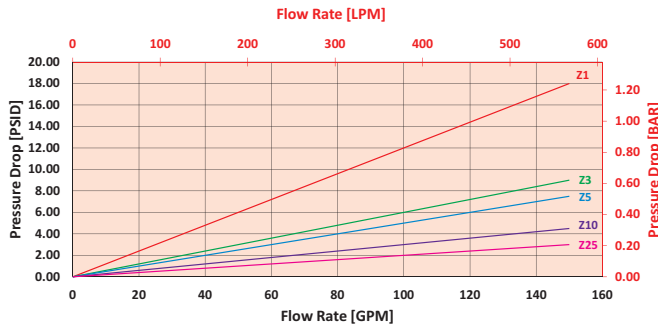

$$\Delta P_{\text{filter}} = \Delta P_{\text{housing}} + (\Delta P_{\text{element}} * V_f)$$

Exercise:

Determine ΔP_{filter} at 80 gpm (303.2 L/min) for MRT18LZ10S24S24 using 160 SUS (34 cSt) fluid.

Use the housing pressure curve to determine $\Delta P_{\text{housing}}$ at 80 gpm. In this case, $\Delta P_{\text{housing}}$ is 1.5 psi (.10 bar) on the graph for the MRT housing.

Use the element pressure curve to determine $\Delta P_{\text{element}}$ at 80 gpm. In this case, $\Delta P_{\text{element}}$ is 2.5 psi (.17 bar) according to the graph for the 18LZ10 element.

Because the viscosity in this sample is 160 SUS (34 cSt), we determine the Viscosity Factor (V_f) by dividing the Operating Fluid Viscosity with the Standard Viscosity of 150 SUS (32 cSt). To best determine your Operating Fluid Viscosity, please reference the chart in Appendix D.

Finally, the overall filter pressure differential, ΔP_{filter} , is calculated by adding $\Delta P_{\text{housing}}$ with the true element pressure differential, ($\Delta P_{\text{element}} * V_f$). The $\Delta P_{\text{element}}$ from the graph has to be multiplied by the viscosity factor to get the true pressure differential across the element.

Solution:

$$\Delta P_{\text{housing}} = 1.5 \text{ psi } [.10 \text{ bar}] \quad | \quad \Delta P_{\text{element}} = 2.5 \text{ psi } [.17 \text{ bar}]$$

$$V_f = 160 \text{ SUS } (34 \text{ cSt}) / 150 \text{ SUS } (32 \text{ cSt}) = 1.1$$

$$\Delta P_{\text{filter}} = 1.5 \text{ psi } + (2.5 \text{ psi } * 1.1) = 4.3 \text{ psi}$$

OR

$$\Delta P_{\text{filter}} = .10 \text{ bar } + (.17 \text{ bar } * 1.1) = .29 \text{ bar}$$

Pressure Drop Information Based on Flow Rate and Viscosity

Filter Model Number Selection

How to Build a Valid Model Number for a Schroeder MRT:

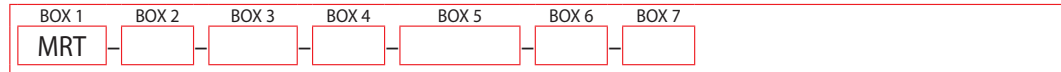

Example: NOTE: One option per box

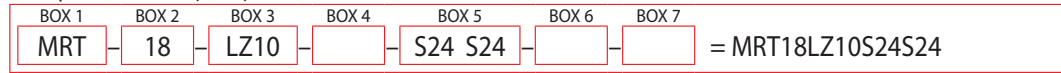

BOX 1	BOX 2	BOX 3	BOX 4
Filter Series	Element Length (in)	Element Size and Media	Seal Material
MRT	18	L3 = L size 3 μ E media (cellulose) L10 = L size 10 μ E media (cellulose) LZ1 = L size 1 μ Excellement® Z-Media® (synthetic) LZ3 = L size 3 μ Excellement® Z-Media® (synthetic) LZ5 = L size 5 μ Excellement® Z-Media® (synthetic) LZ10 = L size 10 μ Excellement® Z-Media® (synthetic) LZ25 = L size 25 μ Excellement® Z-Media® (synthetic) LDZ1 = L size DirtCatcher® 1 μ Excellement® Z-Media® LDZ3 = L size DirtCatcher® 3 μ Excellement® Z-Media® LDZ5 = L size DirtCatcher® 5 μ Excellement® Z-Media® LDZ10 = L size DirtCatcher® 10 μ Excellement® Z-Media® LDZ25 = L size DirtCatcher® 25 μ Excellement® Z-Media®	Omit = Buna N

BOX 5
Specification of both ports is required

Inlet Porting		Inlet Porting Location
Port A S = S24 N = None	Port B S = S24 N = None	

BOX 6

Dirt Alarm® Options	
Omit = None	
Visual	D5 = Visual pop-up
Visual with Thermal Lockout	D8 = Visual w/ thermal lockout
Electrical	MS5 = Electrical w/ 12 in. 18 gauge 4-conductor cable
	MS5LC = Low current MS5
	MS10 = Electrical w/ DIN connector (male end only)
	MS10LC = Low current MS10
	MS11 = Electrical w/ 12 ft. 4-conductor wire
	MS12 = Electrical w/ 5 pin Brad Harrison connector (male end only)
	MS12LC = Low current MS12
Electrical with Thermal Lockout	MS16 = Electrical w/ weather-packed sealed connector
	MS16LC = Low current MS16
	MS17LC = Electrical w/ 4 pin Brad Harrison male connector
	MS5T = MS5 (see above) w/ thermal lockout
	MS5LCT = Low current MS5T
	MS10T = MS10 (see above) w/ thermal lockout
	MS10LCT = Low current MS10T
Electrical Visual	MS12T = MS12 (see above) w/ thermal lockout
	MS12LCT = Low current MS12T
	MS16T = MS16 (see above) w/ thermal lockout
	MS16LCT = Low current MS16T
	MS17LCT = Low current MS17T
	MS13 = Supplied w/ threaded connector & light
	MS14 = Supplied w/ 5 pin Brad Harrison connector & light (male end)
Electrical Visual with Thermal Lockout	MS13DCT = MS13 (see above), direct current, w/ thermal lockout
	MS13DCLCT = Low current MS13DCT
	MS14DCT = MS14 (see above), direct current, w/ thermal lockout
	MS14DCLCT = Low current MS14DC

NOTES:

Box 2. Replacement element part numbers are a combination of Boxes 2, 3, and 4. Example: 18L3

BOX 7

Options
Omit = No sampling valve
SV = Up stream sampling valve

Accessories for Tank-Mounted Filters

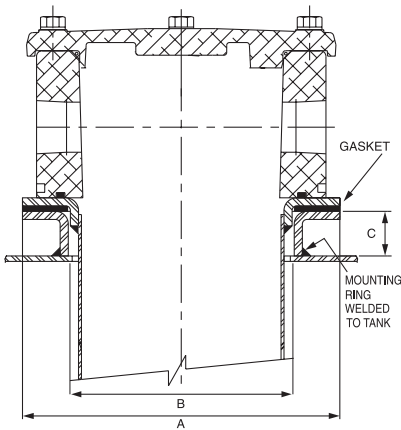

The mounting ring is welded directly to the hydraulic reservoir. The filter is then mounted to the mounting ring with bolts converting the filter to a "weld in" design. The mounting ring eliminates the need to drill and tap the hydraulic reservoir.

Mounting Ring for ST, ZT, RT, RTI and LRT Models

Model Number	Part Number	A	B	C
ST, RT, RTI, LRT	A-LFT-813	7.00 (178)	5.00 (127)	1.00 (25)
ST, RT, RTI, LRT High Version	A-LFT-1448	7.00 (178)	5.00 (127)	1.50 (38)
ZT	A-LFT-1295	6.25 (159)	3.62 (92)	.88 (22)

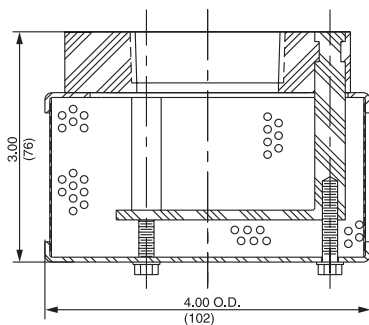

The diffuser option (designated as D for outlet porting option in model number) is threaded to the bushing on the filter bowl below the outlet opening to help decrease turbulent flow in the hydraulic reservoir.

Diffuser for KFT, RT and LRT Models

No other outlet port options are available if the diffuser is used.

Model Number	Part Number	NPTF
RT, KFT	A-LFT-1506	1½"
LRT	A-LFT-1507	2"

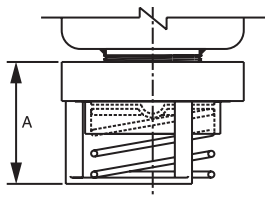

The check valve option (designated as C for outlet porting option in model number) makes it possible to service the filter without draining the oil from the reservoir when the filter is mounted below the oil level. It also prevents reservoir siphoning when system components are serviced.

Check Valve for ST, KFT, RT, LRT and BFT Models

The check valve can also be used on other reservoir return flow lines, where components upstream of the check valve can be serviced without the loss of reservoir oil. The spring setting is .75-1.00 psi cracking. Order by part number shown in chart.

No other outlet port options are available if the check valve is used.

Model Number	Part Number	NPTF	A
ST, KFT, RT	A-LFT-158Q-1	1½"	2.34 (59)
LRT	A-LFT-880	2"	2.34 (59)
BFT	A-BFT-103	3"	4.50 (114)

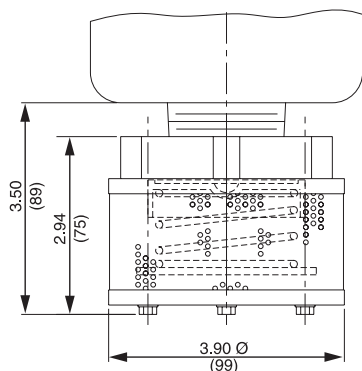

The diffuser/check valve option (designated as CD for outlet porting option in model number) is threaded on to the outlet port and combines the advantages of both separate options in one assembly.

Check Valve Diffuser Combination for KFT and RT Models

Available as a separate item with 1½" NPT female threads, order part number A-LFT-1208.

No other outlet port options are available if the check valve/diffuser is used.

Accessories For Tank-Mounted Filters

IRF
TF1
KF3
KL3
LF1
MLF1
RLD
GRTB
MTA
MTB
ZT
AFT
KFT
RT
RTI
LRT
ART
BRT
TRT
BFT
QT
KTK
LTK
MRT
PAF1
MAF1
MF2

Accessories for Tank-Mounted Filters

Tube Adapter Outlet Port for KFT, RT, LRT and BFT Models

The tube adapter outlet port option (designated as T for outlet porting option in model number) provides the means to direct flow to the bottom of the hydraulic reservoir. Other tube lengths are available for quantity purchases. Contact your Schroeder distributor for details.

Model Number	Dimension A (O.D.) in. (mm)
RT	1.62 (41)
LRT	2.25 (57)
BFT	3.50 (89)

Note: No other outlet port options are available if the tube adapter is used.

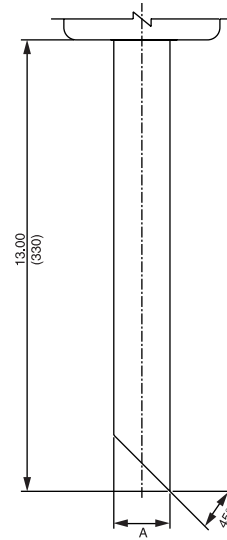

Threaded Outlet Port for ZT, KFT, RT, LRT and BFT Models

The threaded male outlet port is standard on the KFT, RT, LRT and BFT models, and is available as an option on the ZT filter by designating OP for the outlet porting options in the model number.

- RT is furnished with 1½" NPT Male (standard)
- LRT is furnished with 2" NPT Male (standard)
- KFT is furnished with 1 1/2" NPT Male (standard)
- BFT is furnished with 3" NPT Male (standard)
- ZT is furnished with 1½" NPT Male (optional)

Spin-On Filter

PAF1



Features and Benefits

- Spin-On with full ported die cast aluminum head for minimal pressure drop
- Offered in pipe and SAE straight thread porting
- Spin-On thread = 1.00-12UNF-2B
- Visual gauge or electrical switch dirt alarms
- Small profile for use in limited space
- Same day shipment model available

20 gpm
75 L/min
 100 psi
7 bar

Model No. of filter in photograph is PAF16PZ10SY2.

Flow Rating:	Up to 20 gpm (75 L/min) for 150 SUS (32 cSt) fluids
Max. Operating Pressure:	100 psi (7 bar)
Min. Yield Pressure:	150 psi (10 bar), per NFPA T2.6.1
Rated Fatigue Pressure:	Contact factory
Temp. Range:	-20°F to 225°F (-29°C to 107°C)
Bypass Setting:	Cracking: 30 psi (2 bar) Full Flow: 36 psi (2 bar)
Porting Head & Cap:	Die Cast Aluminum
Element Case:	Steel
Weight of PAF1-6P:	1.8 lbs. (0.8 kg)
Element Change Clearance:	2.50" (65 mm)

Filter Housing Specifications

Type Fluid	Appropriate Schroeder Media
Petroleum Based Fluids	All E media (cellulose) and Z-Media* (synthetic)
High Water Content	3 and 10 μ Z-Media* (synthetic)
Invert Emulsions	10 μ Z-Media* (synthetic)
Water Glycols	3 and 10 μ Z-Media* (synthetic)

Fluid Compatibility

Accessories For Tank-Mounted Filters

- IRF
- TF1
- KF3
- KL3
- LF1
- MLF1
- RLD
- GRTB
- MTA
- MTB
- ZT
- AFT
- KFT
- RT
- RTI
- LRT
- ART
- BRT
- TRT
- BFT
- QT
- KTK
- LTK
- MRT
- PAF1**
- MAF1
- MF2

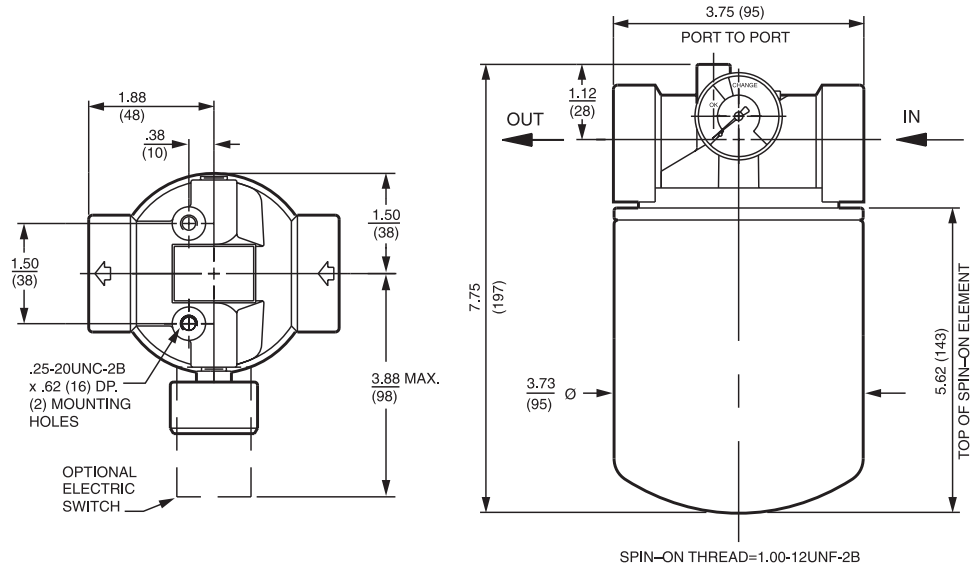

Installation instructions included on element.

Metric dimensions in ().

Element Performance Information & Dirt Holding Capacity

Element	Filtration Ratio Per ISO 4572/NFPA T3.10.8.8 Using automated particle counter (APC) calibrated per ISO 4402			Filtration Ratio per ISO 16889 Using APC calibrated per ISO 11171	
	$\beta_x \geq 75$	$\beta_x \geq 100$	$\beta_x \geq 200$	$\beta_{x(c)} \geq 200$	$\beta_{x(c)} \geq 1000$
P10	15.5	16.2	18.0	N/A	N/A
PZ10	7.4	8.2	10.0	8.0	10.0
PZ25	18.0	20.0	22.5	19.0	24.0

Element	DHC (gm)	Element	DHC (gm)
P10	37	PZ25	23.0
PZ10	16.8		

Element Collapse Rating: 100 psid (7 bar)
 Flow Direction: Outside In
 Element Nominal Dimensions: 3.75" (95 mm) O.D. x 5.5" (140 mm) long

$\Delta P_{\text{housing}}$

PAF1 $\Delta P_{\text{housing}}$ for fluids with sp gr (specific gravity) = 0.86:

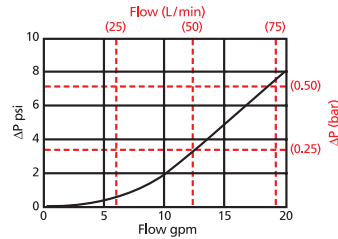

$\Delta P_{\text{element}}$

PZ

Element Pressure Drop versus Flow Rate at 32 cSt (150 SUS)

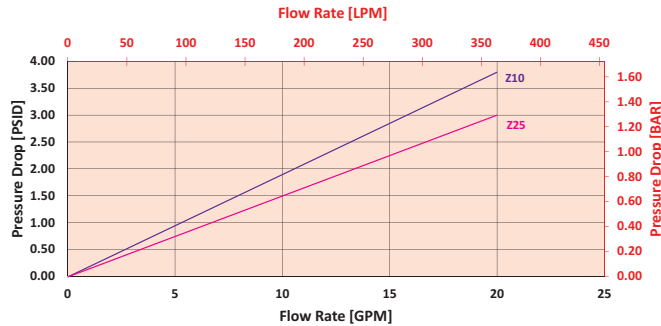

$$\Delta P_{\text{filter}} = \Delta P_{\text{housing}} + (\Delta P_{\text{element}} * V_f)$$

Exercise:

Determine ΔP_{filter} at 10 gpm (37.9 L/min) for PAF16PZ25PY2 using 160 SUS (34 cSt) fluid.

Use the housing pressure curve to determine $\Delta P_{\text{housing}}$ at 10 gpm. In this case, $\Delta P_{\text{housing}}$ is 2 psi (.14 bar) on the graph for the PAF1 housing.

Use the element pressure curve to determine $\Delta P_{\text{element}}$ at 10 gpm. In this case, $\Delta P_{\text{element}}$ is 1.5 psi (.10 bar) according to the graph for the PZ25 element.

Because the viscosity in this sample is 160 SUS (34 cSt), we determine the Viscosity Factor (V_f) by dividing the Operating Fluid Viscosity with the Standard Viscosity of 150 SUS (32 cSt). To best determine your Operating Fluid Viscosity, please reference the chart in Appendix D.

Finally, the overall filter pressure differential, ΔP_{filter} , is calculated by adding $\Delta P_{\text{housing}}$ with the true element pressure differential, ($\Delta P_{\text{element}} * V_f$). The $\Delta P_{\text{element}}$ from the graph has to be multiplied by the viscosity factor to get the true pressure differential across the element.

Solution:

$$\Delta P_{\text{housing}} = 2 \text{ psi } [.14 \text{ bar}] \mid \Delta P_{\text{element}} = 1.5 \text{ psi } [.10 \text{ bar}]$$

$$V_f = 160 \text{ SUS } (34 \text{ cSt}) / 150 \text{ SUS } (32 \text{ cSt}) = 1.1$$

$$\Delta P_{\text{filter}} = 2 \text{ psi } + (1.5 \text{ psi } * 1.1) = 3.7 \text{ psi}$$

OR

$$\Delta P_{\text{filter}} = 14 \text{ bar } + (.10 \text{ bar } * 1.1) = .25 \text{ bar}$$

Pressure Drop Information Based on Flow Rate and Viscosity

Note: If your element is not graphed, use the following equation:
 $\Delta P_{\text{element}} = \text{Flow Rate} \times \Delta P_f$ Plug this variable into the overall pressure drop equation.

Ele.	ΔP
P10	0.17

Filter Model Number Selection

Highlighted product eligible for **QuickDelivery**

How to Build a Valid Model Number for a Schroeder PAF1:

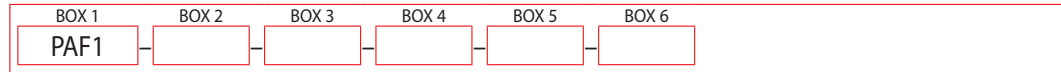

Example: NOTE: One option per box

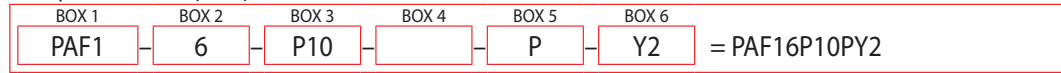

BOX 1	BOX 2	BOX 3	BOX 4
Filter Series	Element Length (in)	Element Size and Media	Seal Material
PAF1	6	P10 = P size 10 μ E media (cellulose) PZ10 = P size 10 μ Excellement® Z-Media® (synthetic) PZ25 = P size 25 μ Excellement® Z-Media® (synthetic)	Omit = Buna N

BOX 5	BOX 6
Inlet Porting	Dirt Alarm® Options
P = ¾" NPTF	Omit = None
S = SAE-12	Visual Y2 = Back-mounted tri-color gauge
	Electrical ES = Electric switch

NOTE:

Box 2. Replacement element part numbers are a combination of Boxes 3 and 4.
Example: P10



Features and Benefits

- Spin-On with full ported die cast aluminum head for minimal pressure drop
- Offered in pipe, SAE straight thread and ISO 228 porting
- Spin-On thread = 1.50-16UN-2B
- Visual gauge or electrical switch dirt alarms
- Small profile for use in limited space
- Available in 7" and 10" element lengths
- Available with NPTF inlet and outlet female test ports

50 gpm
190 L/min
 100 psi
 7 bar

Model No. of filter in photograph is MAF17M10S.

Flow Rating:	Up to 50 gpm (190 L/min) for 150 SUS (32 cSt) fluids
Max. Operating Pressure:	100 psi (7 bar)
Min. Yield Pressure:	200 psi (10 bar), per NFPA T2.6.1
Rated Fatigue Pressure:	Contact factory
Temp. Range:	-20°F to 225°F (-29°C to 107°C)
Bypass Setting:	Cracking: 30 psi (2 bar) Full Flow: 48 psi (3 bar)
Porting Head & Cap:	Die Cast Aluminum
Element Case:	Steel
Weight of MAF1-7M:	4.2 lbs. (1.9 kg)
Weight of MAF1-10M:	5.0 lbs. (2.3 kg)
Element Change Clearance:	2.50" (65 mm)

Filter Housing Specifications

Type Fluid	Appropriate Schroeder Media
Petroleum Based Fluids	All E media (cellulose) and Z-Media® (synthetic)
High Water Content	3 and 10 μ Z-Media® (synthetic)
Invert Emulsions	10 μ Z-Media® (synthetic)
Water Glycols	3 and 10 μ Z-Media® (synthetic)

Fluid Compatibility

Accessories For Tank-Mounted Filters

- IRF
- TF1
- KF3
- KL3
- LF1
- MLF1
- RLD
- GRTB
- MTA
- MTB
- ZT
- AFT
- KFT
- RT
- RTI
- LRT
- ART
- BRT
- TRT
- BFT
- QT
- KTK
- LTK
- MRT
- PAF1
- MAF1**
- MF2

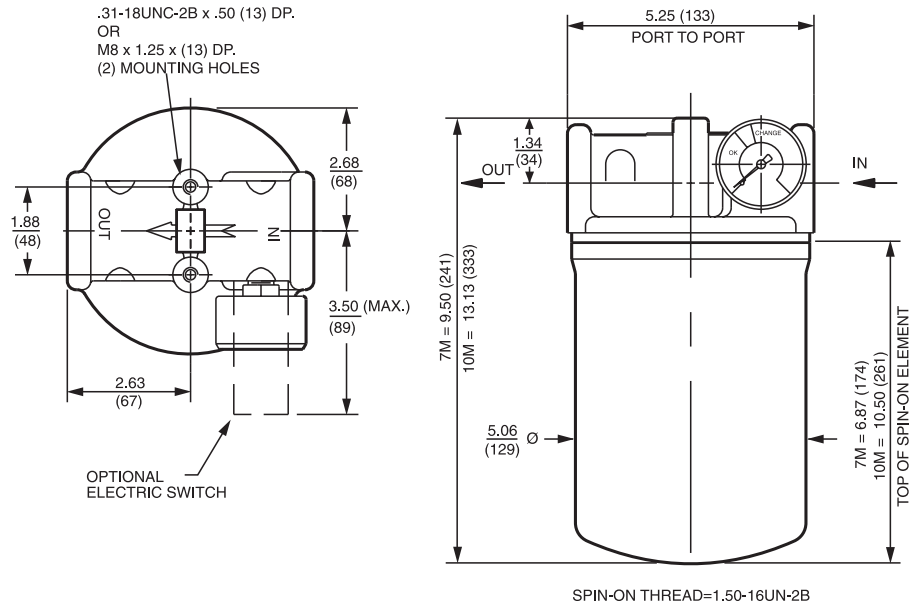

Installation instructions included on element.

Metric dimensions in ().

Element Performance Information & Dirt Holding Capacity

Element	Filtration Ratio Per ISO 4572/NFPA T3.10.8.8 Using automated particle counter (APC) calibrated per ISO 4402			Filtration Ratio per ISO 16889 Using APC calibrated per ISO 11171	
	$\beta_x \geq 75$	$\beta_x \geq 100$	$\beta_x \geq 200$	$\beta_x(c) \geq 200$	$\beta_x(c) \geq 1000$
7MZ3/10MZ3	<1.0	<1.0	<2.0	<4.0	4.8
7MZ10/10MZ10	7.4	8.2	10.0	8.0	10.0
10MZW10	N/A	N/A	N/A	6.9	8.6

Element	DHC (gm)	Element	DHC (gm)
7MZ3	105	10MZW10	53
7MZ10	104		

Element Collapse Rating: 100 psid (7 bar)
 Flow Direction: Outside In
 Element Nominal Dimensions: 7M: 5.0" (125 mm) O.D. x 7.0" (180 mm) long
 10M: 5.0" (125 mm) O.D. x 10.5" (261 mm) long

$\Delta P_{\text{housing}}$

MAF1 $\Delta P_{\text{housing}}$ for fluids with sp gr (specific gravity) = 0.86:

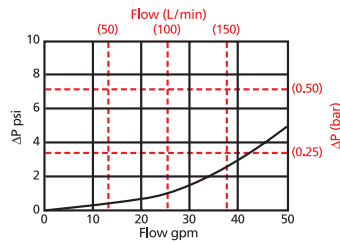

Pressure Drop Information Based on Flow Rate and Viscosity

$\Delta P_{\text{element}}$

7MZ

Element Pressure Drop versus Flow Rate at 32 cSt (150 SUS)

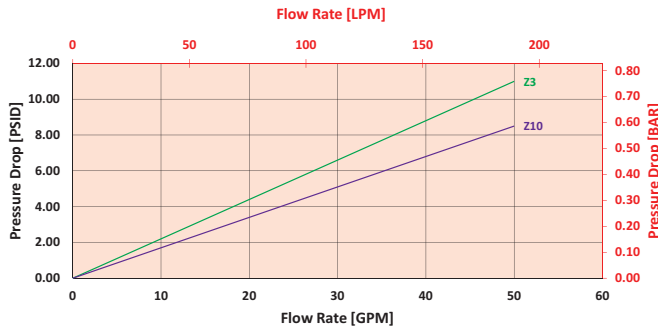

10MZ

Element Pressure Drop versus Flow Rate at 32 cSt (150 SUS)

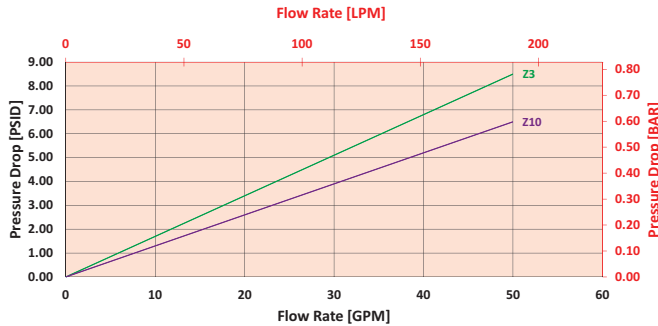

$$\Delta P_{\text{filter}} = \Delta P_{\text{housing}} + (\Delta P_{\text{element}} * V_f)$$

Exercise:

Determine ΔP_{filter} at 40 gpm (151.6 L/min) for MAF17MZ10PY2 using 160 SUS (34 cSt) fluid.

Use the housing pressure curve to determine $\Delta P_{\text{housing}}$ at 40 gpm. In this case, $\Delta P_{\text{housing}}$ is 3 psi (.21 bar) on the graph for the MAF1 housing.

Use the element pressure curve to determine $\Delta P_{\text{element}}$ at 40 gpm. In this case, $\Delta P_{\text{element}}$ is 7 psi (.48 bar) according to the graph for the 7MZ10 element.

Because the viscosity in this sample is 160 SUS (34 cSt), we determine the Viscosity Factor (V_f) by dividing the Operating Fluid Viscosity with the Standard Viscosity of 150 SUS (32 cSt). To best determine your Operating Fluid Viscosity, please reference the chart in Appendix D.

Finally, the overall filter pressure differential, ΔP_{filter} , is calculated by adding $\Delta P_{\text{housing}}$ with the true element pressure differential, ($\Delta P_{\text{element}} * V_f$). The $\Delta P_{\text{element}}$ from the graph has to be multiplied by the viscosity factor to get the true pressure differential across the element.

Solution:

$\Delta P_{\text{housing}} = 3 \text{ psi } [.21 \text{ bar}] \mid \Delta P_{\text{element}} = 7 \text{ psi } [.48 \text{ bar}]$

$V_f = 160 \text{ SUS } (34 \text{ cSt}) / 150 \text{ SUS } (32 \text{ cSt}) = 1.1$

$\Delta P_{\text{filter}} = 3 \text{ psi} + (7 \text{ psi} * 1.1) = 10.7 \text{ psi}$

OR

$\Delta P_{\text{filter}} = .21 \text{ bar} + (.48 \text{ bar} * 1.1) = .74 \text{ bar}$

Note:

If your element is not graphed, use the following equation:

$\Delta P_{\text{element}} = \text{Flow Rate} \times \Delta P_f$ Plug this variable into the overall pressure drop equation.

Ele.	ΔP
7M3	0.23
7M10	0.14

Filter Model Number Selection

How to Build a Valid Model Number for a Schroeder MAF1:

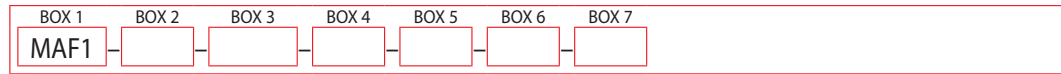

Example: NOTE: One option per box

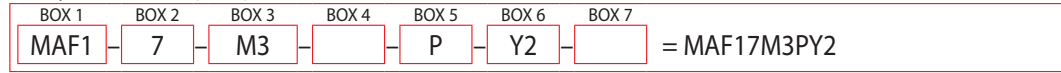

BOX 1	BOX 2	BOX 3	BOX 4
Filter Series	Element Length (in)	Element Size and Media	Seal Material
MAF1	7	M3 = M size 3 μ E media (cellulose)	Omit = Buna N
	10	M10 = M size 10 μ E media (cellulose)	V = Viton®
		MZ3 = M size 3 μ Excellement® Z-Media® (synthetic)	
		MZ10 = M size 10 μ Excellement® Z-Media® (synthetic)	
		MZW10 = M size 10 μ Aqua-Excellement™ ZW media	
		MW = M size W media (water removal)	

BOX 5	BOX 6	BOX 7
Porting Options	Dirt Alarm® Options	Additional Options
P = 1 1/4" NPTF	Omit = None	Omit = None
S = SAE-20	Visual Y2 = Back-mounted tri-color gauge	L = Two 1/8" NPTF inlet and outlet female test ports
B = ISO 228 G-1 1/4"	Electrical ES = Electric switch	

NOTES:

- Box 2. Replacement element part numbers are a combination of Boxes 2, 3, and 4. Replacement element part numbers for 7" length begin with M. Replacement element part numbers for 10" length begin with 10M. Examples: M3V; 10MZ3V 10" only available with MZ3 and MZ10.
- Box 3. ZW media only available for 10" element.
- Box 4. For option V, all aluminum parts are anodized. Viton® is a registered trademark of DuPont Dow Elastomers.
- Box 5. B porting option supplied with metric mounting holes.

Spin-On Filter

MF2



Features and Benefits

- Spin-On with full ported cast iron head for minimal pressure drop
- Offered in pipe, SAE straight thread and ISO 228 porting
- Spin-On thread = 1.50-16UN-2B
- Various Dirt Alarm® options
- Available in 7" and 10" element lengths

60 gpm
230 L/min
150 psi
10 bar

Model No. of filter in photograph is MF27M10SD5.

Flow Rating:	Up to 60 gpm (230 L/min) for 150 SUS (32 cSt) fluids
Max. Operating Pressure:	150 psi (10 bar)
Min. Yield Pressure:	250 psi (17 bar), per NFPA T2.6.1
Rated Fatigue Pressure:	Contact factory
Temp. Range:	-20°F to 225°F (-29°C to 107°C)
Bypass Setting:	Cracking: 30 psi (2 bar) Full Flow: 48 psi (3 bar)
Porting Head:	Cast Iron
Element Case:	Steel
Weight of MF2-7M:	8.6 lbs. (3.9 kg)
Element Change Clearance:	1.50" (40 mm)

Filter Housing Specifications

Type Fluid	Appropriate Schroeder Media
Petroleum Based Fluids	All E media (cellulose) and Z-Media® (synthetic)
High Water Content	3 and 10 μ Z-Media® (synthetic)
Invert Emulsions	10 μ Z-Media® (synthetic)
Water Glycols	3 and 10 μ Z-Media® (synthetic)

Fluid Compatibility

Accessories For Tank-Mounted Filters

- IRF
- TF1
- KF3
- KL3
- LF1
- MLF1
- RLD
- GRTB
- MTA
- MTB
- ZT
- AFT
- KFT
- RT
- RTI
- LRT
- ART
- BRT
- TRT
- BFT
- QT
- KTK
- LTK
- MRT
- PAF1
- MAF1
- MF2**

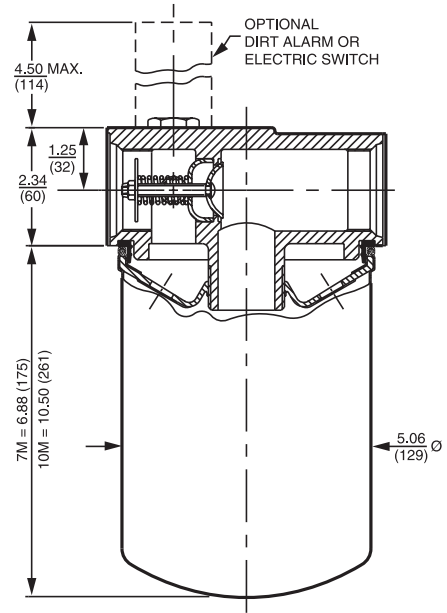
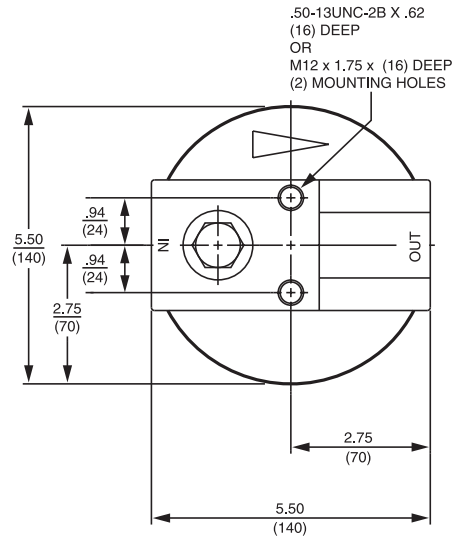

SPIN-ON THREAD=1.50-16UN-2B

Installation instructions included on element.

Metric dimensions in ().

Element Performance Information & Dirt Holding Capacity

Element	Filtration Ratio Per ISO 4572/NFPA T3.10.8.8 Using automated particle counter (APC) calibrated per ISO 4402			Filtration Ratio per ISO 16889 Using APC calibrated per ISO 11171	
	$\beta_x \geq 75$	$\beta_x \geq 100$	$\beta_x \geq 200$	$\beta_x^{(c)} \geq 200$	$\beta_x^{(c)} \geq 1000$
7MZ3/10MZ3	<1.0	<1.0	<2.0	<4.0	4.8
7MZ10/10MZ10	7.4	8.2	10.0	8.0	10.0
10MZW10	N/A	N/A	N/A	6.9	8.6

Element	DHC (gm)	Element	DHC (gm)
7MZ3	105		
7MZ10	104	10MZW10	53

Element Collapse Rating: 100 psid (7 bar)
 Flow Direction: Outside In
 Element Nominal Dimensions: 7M: 5.0" (125 mm) O.D. x 7.0" (180 mm) long
 10M: 5.0" (125 mm) O.D. x 10.5" (261 mm) long

$\Delta P_{\text{housing}}$

MF2 $\Delta P_{\text{housing}}$ for fluids with sp gr (specific gravity) = 0.86:

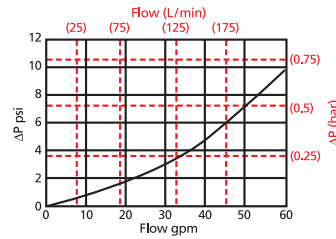

$\Delta P_{\text{element}}$

7MZ

Element Pressure Drop versus Flow Rate at 32 cSt (150 SUS)

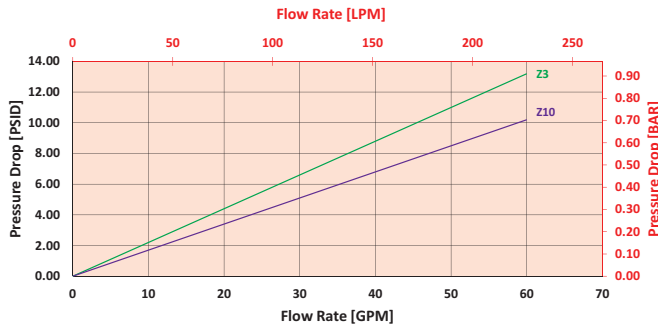

$$\Delta P_{\text{filter}} = \Delta P_{\text{housing}} + (\Delta P_{\text{element}} * V_f)$$

Exercise:

Determine ΔP_{filter} at 40 gpm (151.6 L/min) for MF27MZ10PD5 using 160 SUS (34 cSt) fluid.

Use the housing pressure curve to determine $\Delta P_{\text{housing}}$ at 40 gpm. In this case, $\Delta P_{\text{housing}}$ is 5 psi (.34 bar) on the graph for the MF2 housing.

Use the element pressure curve to determine $\Delta P_{\text{element}}$ at 40 gpm. In this case, $\Delta P_{\text{element}}$ is 7 psi (.48 bar) according to the graph for the 7M3 element.

Because the viscosity in this sample is 160 SUS (34 cSt), we determine the Viscosity Factor (V_f) by dividing the Operating Fluid Viscosity with the Standard Viscosity of 150 SUS (32 cSt). To best determine your Operating Fluid Viscosity, please reference the chart in Appendix D.

Finally, the overall filter pressure differential, ΔP_{filter} , is calculated by adding $\Delta P_{\text{housing}}$ with the true element pressure differential, ($\Delta P_{\text{element}} * V_f$). The $\Delta P_{\text{element}}$ from the graph has to be multiplied by the viscosity factor to get the true pressure differential across the element.

Solution:

$$\Delta P_{\text{housing}} = 5 \text{ psi } [.34 \text{ bar}] \mid \Delta P_{\text{element}} = 7 \text{ psi } [.48 \text{ bar}]$$

$$V_f = 160 \text{ SUS (34 cSt)} / 150 \text{ SUS (32 cSt)} = 1.1$$

$$\Delta P_{\text{filter}} = 5 \text{ psi} + (7 \text{ psi} * 1.1) = 12.7 \text{ psi}$$

OR

$$\Delta P_{\text{filter}} = .34 \text{ bar} + (.48 \text{ bar} * 1.1) = .87 \text{ bar}$$

Pressure Drop Information Based on Flow Rate and Viscosity

Note: If your element is not graphed, use the following equation:
 $\Delta P_{\text{element}} = \text{Flow Rate} \times \Delta P_f$ Plug this variable into the overall pressure drop equation.

Ele.	ΔP
7M3	0.23
7M10	0.14

Filter Model Number Selection

How to Build a Valid Model Number for a Schroeder MF2:

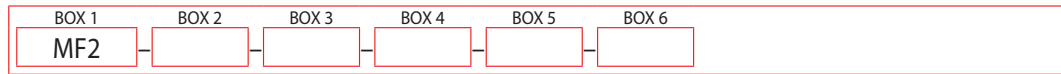

Example: Option 1 NOTE: One option per box

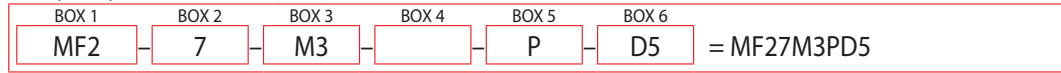

BOX 1	BOX 2	BOX 3	BOX 4	BOX 5
Filter Series	Element Length (in)	Element Size and Media	Seal Material	Porting Options
MF2	7 10	M3 = M size 3 μ E media (cellulose) M10 = M size 10 μ E media (cellulose) MZ3 = M size 3 μ Excellement [®] Z-Media [®] (synthetic) MZ10 = M size 10 μ Excellement [®] Z-Media [®] (synthetic) MZW10 = M size 10 μ Aqua-Excellement [™] ZW media MW = M size W media (water removal)	Omit = Buna N V = Viton [®]	P = 1 $\frac{1}{4}$ " NPTF S = SAE-20 B = ISO 228 G-1 $\frac{1}{4}$ "

BOX 6	
Dirt Alarm [®] Options	
	Omit = None
Visual	D5 = Visual pop-up
Visual with Thermal Lockout	D8 = Visual w/ thermal lockout
Electrical	MS5 = Electrical w/ 12 in. 18 gauge 4-conductor cable MS5LC = Low current MS5 MS10 = Electrical w/ DIN connector (male end only) MS10LC = Low current MS10 MS11 = Electrical w/ 12 ft. 4-conductor wire MS12 = Electrical w/ 5 pin Brad Harrison connector (male end only) MS12LC = Low current MS12 MS16 = Electrical w/ weather-packed sealed connector MS16LC = Low current MS16 MS17LC = Electrical w/ 4 pin Brad Harrison male connector
Electrical with Thermal Lockout	MS5T = MS5 (see above) w/ thermal lockout MS5LCT = Low current MS5T MS10T = MS10 (see above) w/ thermal lockout MS10LCT = Low current MS10T MS12T = MS12 (see above) w/ thermal lockout MS12LCT = Low current MS12T MS16T = MS16 (see above) w/ thermal lockout MS16LCT = Low current MS16T MS17LCT = Low current MS17T
Electrical Visual	MS13 = Supplied w/ threaded connector & light MS14 = Supplied w/ 5 pin Brad Harrison connector & light (male end)
Electrical Visual with Thermal Lockout	MS13DCT = MS13 (see above), direct current, w/ thermal lockout MS13DCLCT = Low current MS13DCT MS14DCT = MS14 (see above), direct current, w/ thermal lockout MS14DCLCT = Low current MS14DCT

NOTES:

- Box 2. Replacement element part numbers are a combination of Boxes 2, 3, and 4. Replacement element part numbers for 7" length begin with M. Replacement element part numbers for 10" length begin with 10M. Example: M3; 10MZ3. 10" only available with MZ3 and MZ10.
- Box 3. ZW media only available for 10" element.
- Box 4. Viton[®] is a registered trademark of DuPont Dow Elastomers.
- Box 5. B porting option supplied with metric mounting holes.