

# Oil Sight Glasses

When seeing and maintaining the level of oil in your reservoir is critical, the Sight Level Gauge (SLG) provides constantly monitoring of the oil level in the reservoir.

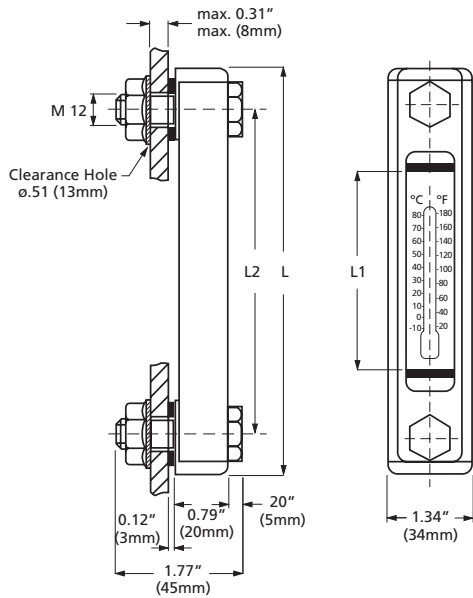

## SLG Fluid Level Indicator



Air Breathers

Suction Separators and Strainers

Oil Sight Glasses

Model Code	Size	Dimensions		
		L	L1	L2
SLG-3	76	4.25"	1.46"	2.99"
SLG-5	127	6.26"	2.99"	5.00"
SLG-10	254	11.26"	7.99"	10.00"