



The automatic backflushing RF4 filter is a self-cleaning system for removing particles from low viscosity fluids. Its robust construction and automatic backflushing capability make a major contribution to operational reliability and reduce operating and maintenance costs. The slotted tube or SuperMesh™ filter elements with filtration rates from 25 to 1000 µm ensure highly effective separation of contaminating particles from the process medium.

Automatic cleaning starts as soon as the elements become contaminated. The flow of filtrate is not interrupted during the backflushing procedure. Two sizes allow flow rates from 10-60 gpm. The RF4 is available as a fully automatic or purely manual version.

Numerous combinations of materials and equipment as well as individually adjustable control parameters allow optimum adaptation of the filter to any application.

OPERATION OF THE RF4

Filtration

The fluid to be filtered flows through the slotted tube filter elements of the backflushing filter passing from the inside to the outside. Contamination particles collect on the smooth inside of the filter elements. As the level of the collected contamination increases, the differential pressure between the contaminated and clean sides of the filter increases. When the differential pressure reaches its pre-set value, the backflushing cycle begins.

Triggering Automatic Backflushing

Backflushing is triggered automatically when the differential pressure set point is exceeded. As soon as backflushing has been triggered, the filter starts to clean the filter elements.

Triggering Backflushing on Manual Version

When the differential pressure set point is reached, the visual clogging alarm indicates to an operator or maintenance personnel that a backflush cycle is needed.

Backflushing of the Filter Elements – Backflushing Cycle

The cycle begins with the element plate turning 90°. This brings a clean filter element into filtration, and a contaminated filter element is positioned over the fixed flushing connection.

The backflush valve is opened.

The differential pressure between filtrate side and backflush line causes a small amount of the filtrate to reverse flow through the element to be cleaned. The contamination particles collected on the inside of the filter element are loosened and flushed into the backflush line via the flushing arm. As soon as the “backflushing time per element” has elapsed, the backflushing valve is closed. The backflushing cycle is terminated when all the filter elements have been cleaned. On the RF4 with manual backflushing, the element plate including filter elements, is turned and the backflushing valve is opened by hand. Each filter element is cleaned successively in this manner.

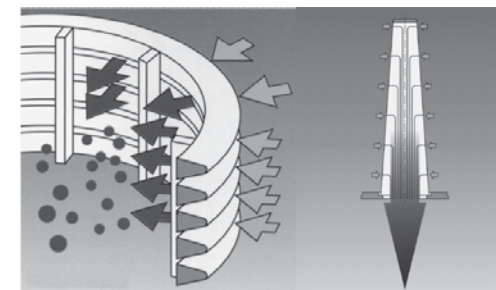
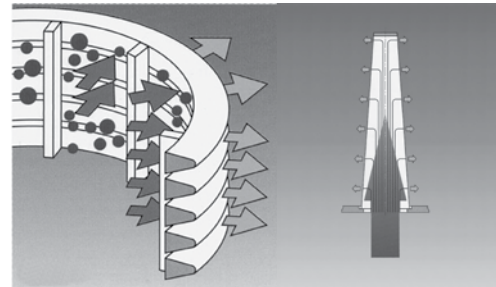

SPECIAL FEATURES OF THE RF4

Isokinetic Filtering and Backflushing

The special conical shape and configuration of the filter elements allows for even flow, resulting in low pressure drop and complete cleaning of the elements. The advantage: fewer backflushing cycles and lower loss of backflushing fluid.

Pulse-aided Backflushing

The filter element to be backflushed remains in the flushing position for only a few seconds. Rapid opening of the pneumatic backflushing valve generates a pressure surge in the openings of the filter elements that provides a pulse-aided cleaning effect to the backflushing process.

Low Backflushing Quantities Due to Cyclic Control

The backflush valve opens and closes during backflushing of each filter element, further minimizing the amount of filtrate needed to effectively clean the element.

Backflushing Filter AutoFilt® RF4

RF4

Water Applications

Fluid	Max. Flow Rate gpm (L/min)	
	RF4-1	RF4-2
Water	32(120)	60(220)

The flow rate ranges indicated apply to filtration ratings $\geq 100 \mu\text{m}$

Important
The pressure drop curves apply to water and other fluids up to a viscosity of 11 mm²/s.

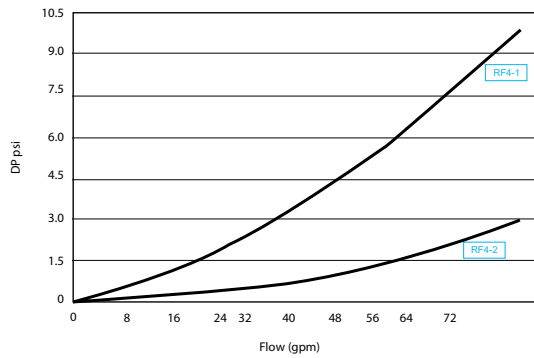

Cooling Lubricant Applications

Material Handling	Type of Machining	Max. Flow Rate gpm (L/min)	
		RF4-1	RF4-2
Aluminum	Cutting	26 (100)	53 (200)
Cast Iron	Cutting	18 (70)	42 (160)
Carbon Steel	Cutting	21 (80)	48 (180)
Stainless Steel	Cutting	21 (80)	48 (180)
Aluminum	Grinding	24 (90)	53 (200)
Cast Iron	Grinding	13 (50)	37 (140)
Carbon Steel	Grinding	16 (60)	40 (150)
Stainless Steel	Grinding	16 (60)	40 (150)

Circuit Diagram

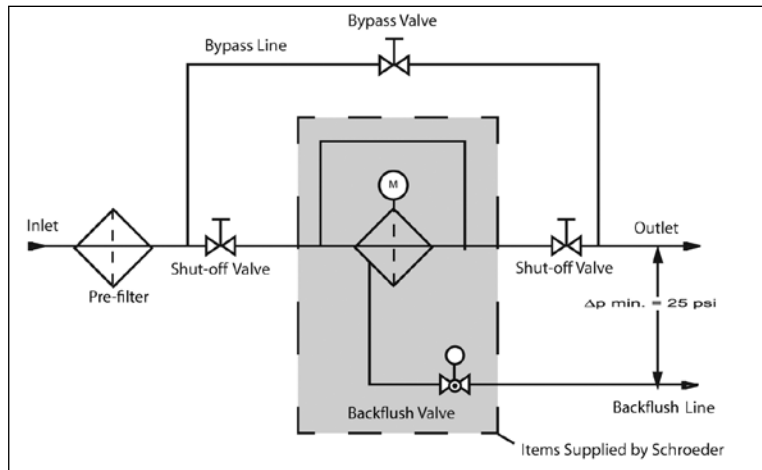

STEEL MAKING	PULP & PAPER	WASTE WATER TREATMENT	AUTOMOTIVE MANUFACTURING	INDUSTRIAL	THERMAL TRANSFER	MARINE	MACHINE TOOL

Industries Served

- RF3-C
- RF3-0
- RF3-1
- RF3-2
- RF3-2.5
- RF3-3
- RF3-4
- RF3-5
- RF3-6
- RF3-7
- RF3-8
- RF5
- RF7
- RF10
- RF4**
- RF4-1
- RF4-2
- RF12
- BTU
- ATF
- PLF1
- PVD