

# Suction Strainer Elements

## Hose Barb | SSHB Tank Mounted Suction Strainer Elements

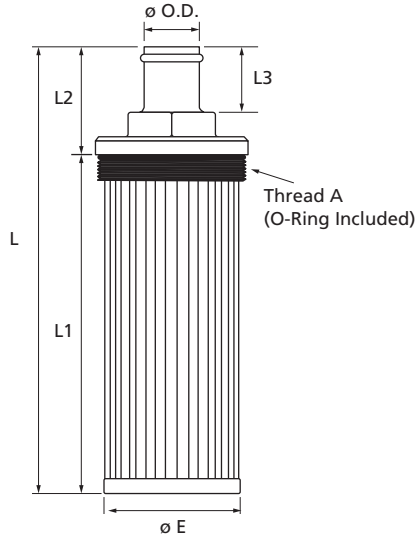

These suction strainers have additional fittings attached for hose barb settings.

Model Code	Optional 3 psi Bypass (Omit) = None (-3) = Bypass valve	Per SAEJ514		Hex Size	GPM	Dimensions				
		THD A	O.D.			L	L1	L2	L3	E
SSHB-1.25-100	(Omit) = None	2-1/2"-12	1.25"	1.50"	14	10.00"	8.00"	2.00"	1.25"	2.12"
SSHB-2-100	(-3) = Bypass valve	3-3/8"-12	2.00"	2.50"	40	10.80"	7.84"	2.97"	2.00"	3.22"

## NPT Tank Mounted Suction Strainer Element

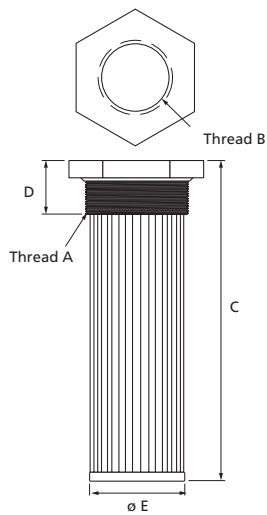

These suction strainers have external fitting installed for male NPT ports.

Model Code	Optional 5 psi Bypass (Omit) = None (-5) = Bypass valve	GPM	Screen Area (Sq. In.)	THD A	THD B	Hex Size	Dimensions		
							C	D	ØE
SSP-2-100	(Omit) = None	50	260	3" NPT	2" NPT	3.30	10.25"	1.70"	3.03"
SSP-3-100	(-5) = Bypass valve	100	315	4" NPT	3" NPT	5.00	11.30"	1.80"	3.78"