

ULTRASCREEN®

Tertiary treatment will never be the same

3



ULTRASCREEN 3
GENERATION 3

ULTRASCREEN 3



nuove energie
technological thinking

DIFFERENT FROM
THE OTHERS,
ALWAYS UNIQUE.

To be unique you have to be different: this is what we think and what we believe in. Since the first day.

Like Nuove Energie there's only Nuove Energie. Since 1980 we manufacture wastewater treatment machines that are different from all the others, result of engineering intuitions out of the ordinary: it is not a coincidence that they are entirely built in stainless steel, they stand out for revolutionary internal mechanisms and they are internationally patented and certified.

.....

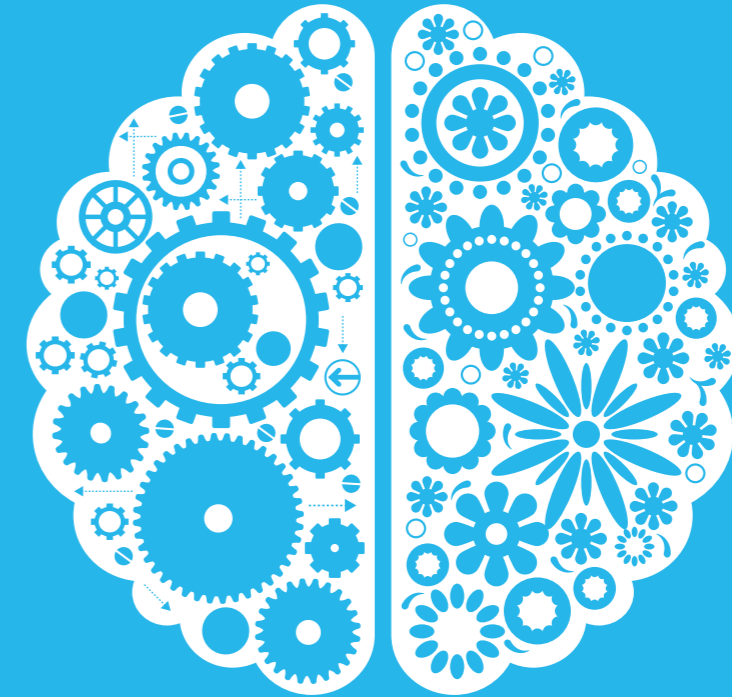

Human and Technology: two different aspects of the same Company. If technology is the goal, human value is the way to achieve it: you can't have one without the other.

One Company, two distinctive features. Strong and outstanding. The technologic one, which is put into effect with well-advanced products, and the human one, which is represented by all those people who every day, with the same effort as ever, develop the highest technology and the most advanced engineering. Never stopping.

Schroeder
INDUSTRIES

HYDAC

nuove energie
technological thinking

The value of Water.

RECYCLING
MEANS
SAVING.

What do we talk about when we talk about water?

We talk about an element that we take for granted; we only need to turn the faucet on to see it flow. But water is a truly precious element. It is so valued to be called Blue Gold. It is therefore to be saved and not to be wasted.

Nuove Energie has always worked with water and for water. We have understood that recovering water is not only important, but it can become fundamental for those companies that work with big amounts of it and for which the water reuse represents real economic benefits. The experience we've gained in these years led us to the realization of extraordinary and incomparable microfiltration machines: in order to meet the always more specific requests of the companies with more specific products.

.....



TERTIARY TREATMENT WILL NEVER BE THE SAME.

Ultrascreen® is a microfiltration system with no equal: exceptional in every manufacture detail and extraordinary in its working principle.

The essence of our philosophy is held in this product. A microfiltration machine for the tertiary treatment of reclaimed wastewater, absolutely incomparable: for the choice of materials, for the technology used and for the philosophy that inspires it. An entirely stainless steel machine awarded the most prestigious certifications that revolutionizes the tertiary treatment and allows to reuse the outlet water of the treatment plant.

.....



DYNAMIC TANGENTIAL FILTRATION®: THE BEST TECHNOLOGY POSSIBLE.

The disks in continuous rotation and the flow, crossing the filtration surface tangentially instead of orthogonally, are the main features of the Ultrascreen® technology.

The main feature and the uniqueness of Ultrascreen® have a specific name: Dynamic Tangential Filtration®. Basically, the wastewater crosses the rotating filtration surface tangentially instead of orthogonally, as it does in the other filters. This guarantees great advantages. The angle of incidence between the influent and the filtering media, combined with the continuous disks rotation, allows to separate the micro particles contained in the wastewater.

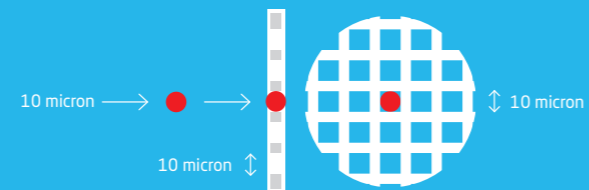

Traditional filtration

The 10 microns diameter solid particle, is able to pass through the mesh, whose diameter is the same as the particle's.

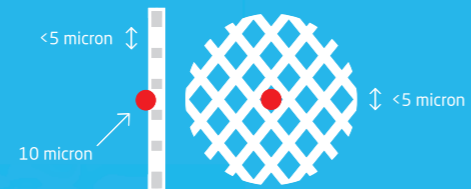

Dynamic Tangential Filtration®

The inclination to the water flow crossing surface keeps the 10 microns diameter particle from crossing the mesh.



TRIPLES THE ADVANTAGE, INCREASES THE PERFORMANCES.



The Dynamic Tangential Filtration® brings several real and absolutely great advantages.



Triple water flow

The Dynamic Tangential Filtration® technology allows to treat specific flow rates three times higher than other filtration systems on the market.



Better water transmittance

The Dynamic Tangential Filtration® improves the water transmittance, a fundamental factor for the efficiency of the UV-C rays disinfection processes.



Reduced footprint

The higher treated flow allows to use smaller machines compared to our competitors.



EXCELLENCE IS IN THE DETAILS.

Some construction details represent a real distinctive mark for Ultrascreen®: the microfilter designed to be second to none and to always guarantee the best.

Possibility to modify the parameters

The Ultrascreen® microfilter is the only machine that allows to modify the filtration parameters: TSS OUT amount, installed filtering meshes, disks rotation speed, probes height, water level inside the tank, washing pressure, drain valve timing.

Indifference to the TSS IN variation

The Ultrascreen® system has a remarkable indifference to the variation of the TSS IN parameter: this feature proves the flexibility of the machine when it comes to load variations and underlines the difference with all the other machines that clog up when exceeding the project conditions.

4 Bar maximum washing pressure

Ultrascreen® has a 4 Bar maximum washing pressure: the wear and tear of the filtering meshes is therefore lower than other machines on the market that use a higher pressure.

Lower backwashing water flow rate

Ultrascreen® cleans the filtering meshes with a restrained backwashing water flow and a moderated water pressure. Therefore, the backwashing water flow rate is lower than other machines.

TERTIARY TREATMENT IN SIX STEPS.

From the moment when the Influent enters into the machine to when the filtered water comes out: here's Ultrascreen® working principle:

The influent enters into the inlet chamber while the filtering disks are not rotating.

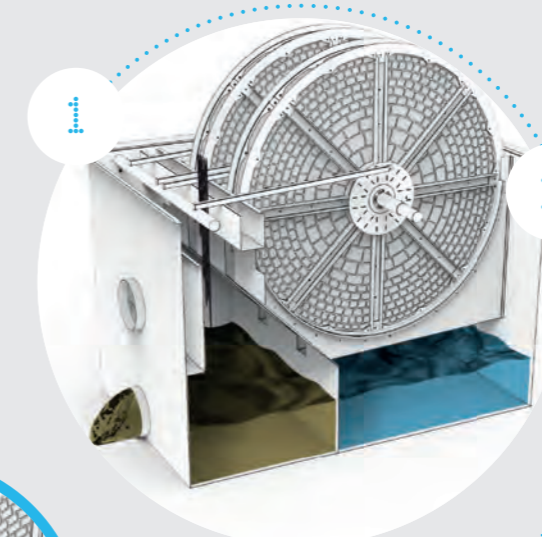

The filtering disks start their continuous rotation due to the raising of the influent.

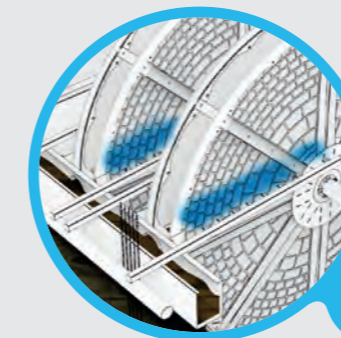

The continuous rotation of the disks guarantees the efficiency of the Dynamic Tangential Filtration®. The precoat formation on the filtering media increases the filtration quality.

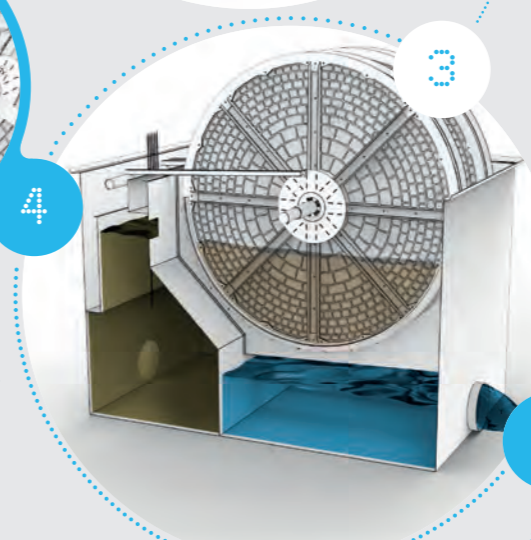

The backwashing system begins to work at the reaching of a prearranged level in the inlet chamber while the filtered water keeps draining with a constant flow rate.

The backwashing water is captured in the collecting duct located between the filtering disks and drained by a specific duct.

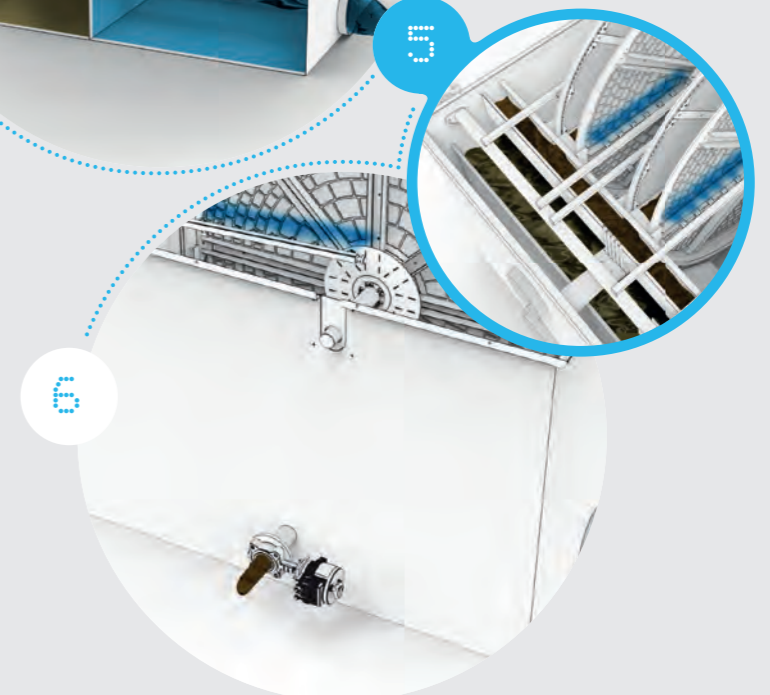

The solids sedimented between the filtering disks pairs are discharged by a pipe with motorized valve.

ULTRASCREEN® ALWAYS THAT EXTRA BIT.

All it takes is to look at our plus to understand the uniqueness of Ultrascreen® and see the deep difference between us and our competitors.



100% Stainless steel

The frame, the filtering meshes and the rotating disks are all entirely stainless steel manufactured. A manufacturing choice that not only focuses on resistance and durability but also allows to clearly stand out from the competitors who use plastic materials.



Easy maintenance

Ultrascreen® is designed in order to make maintenance operations easier. But that's not all: the covers are equipped with pneumatic dampers, the filtering sectors can be quickly removed and it is possible to remove the nozzles from the washing ramp by simply rotating them.



Simple manufacturing and installation

The usage of the microfilter is very intuitive thanks to the extremely easy setting. Also, the machine is already equipped with electric panel and it only needs the hydraulic connection to the plant.



Combinable with existent plants

Ultrascreen® is totally autonomous and could easily be installed in existent plants without having to modify the concrete construction nor to install additional pump stations.

AISI 304 or 316L stainless steel covers, equipped with pneumatic dampers.

"Quick&Easy" filtering sectors, entirely built in AISI 316L stainless steel, quickly and easily replaceable.

90° pivoting washing pipe with manually removable spray headers.

Electric level sensors for backwashing pump activation.

Pinion/chain/sprocket system for lower consumption.

Electric panel with PLC installed on board and electric connections for all the electromechanical components placed in stainless steel ducts.

Compact dimensions in order to easily fit into the standard containers and simplify the transportation.

Motorized electro-valve to discharge the sedimented solids.

Totally built in certified AISI 304 or 316L stainless steel.

Outlet pipe for inlet and outlet chambers cleaning.

Centrifugal backwashing pump with safety cover.

AISI 304 or 316L stainless steel washing circuit, equipped with safety basket strain.

STAINLESS STEEL HEART

Ultrascreen® has a stainless steel heart, with continuous welding.

The heart of Ultrascreen® is its filtering sectors, manufactured in AISI 316L stainless steel. The filtering mesh, also in AISI 316L stainless steel, is tensioned and micro-welded to the frame. This patented technology clearly distinguishes Nuove Energie's filtering sector from the competitors', who use glues and plastic materials to fix the filtering mesh.

Il cuore di Ultrascreen® è di acciaio inox, con microsaldature in continuo.

Il cuore di Ultrascreen® sono i suoi settori filtranti, realizzati in acciaio inox AISI 316L. La rete filtrante, anch'essa in acciaio inox AISI 316L è tensionata e microsaldata al telaio. Questa tecnologia brevettata, distingue nettamente il settore filtrante Nuove Energie da quello dei competitors, che utilizzano colle e materiali plastici per il fissaggio della rete filtrante.

Continuous micro-welding of the filtering mesh, after tensioning. Paint finishing coat.

Gaskets in special sealing adhesive elastomer.

AISI 316L stainless steel support frame.

AISI 316L stainless steel filtering mesh.

Rete filtrante in acciaio inox AISI 316L.

Nuove Energie® branded identification code of the filtering sector, that certifies the component's authenticity.

GENERATION 3: TWO VERSIONS FOR ALL TYPES OF INSTALLATIONS

With stainless steel frame:

Specifically designed for the "above-ground" installation, allows extreme footprint optimization and perfect accessibility to all components, ensuring maximum ease of maintenance.



For concrete tank installation.

The Ultrascreen® technology and the Dynamic Tangential Filtration® for the installation in concrete tank. Perfect for projects where the installation of the unit below the ground level is more suitable, as well as for the retrofitting of outdated existing filtering sections.

GENERATION 3: MAXIMUM POSSIBILITY OF PLANT CONFIGURATION.

With the Ultrascreen® microfilter, the available configurations of inlet, outlet and backwash piping are several.

Indeed, thanks to the special structure of the internal chambers of the unit, Ultrascreen® can adapt to the most various layout requirements, in order to always obtain the maximum optimization of piping and footprint.

Ultrascreen® GEN3 with stainless steel frame.
Installation examples:

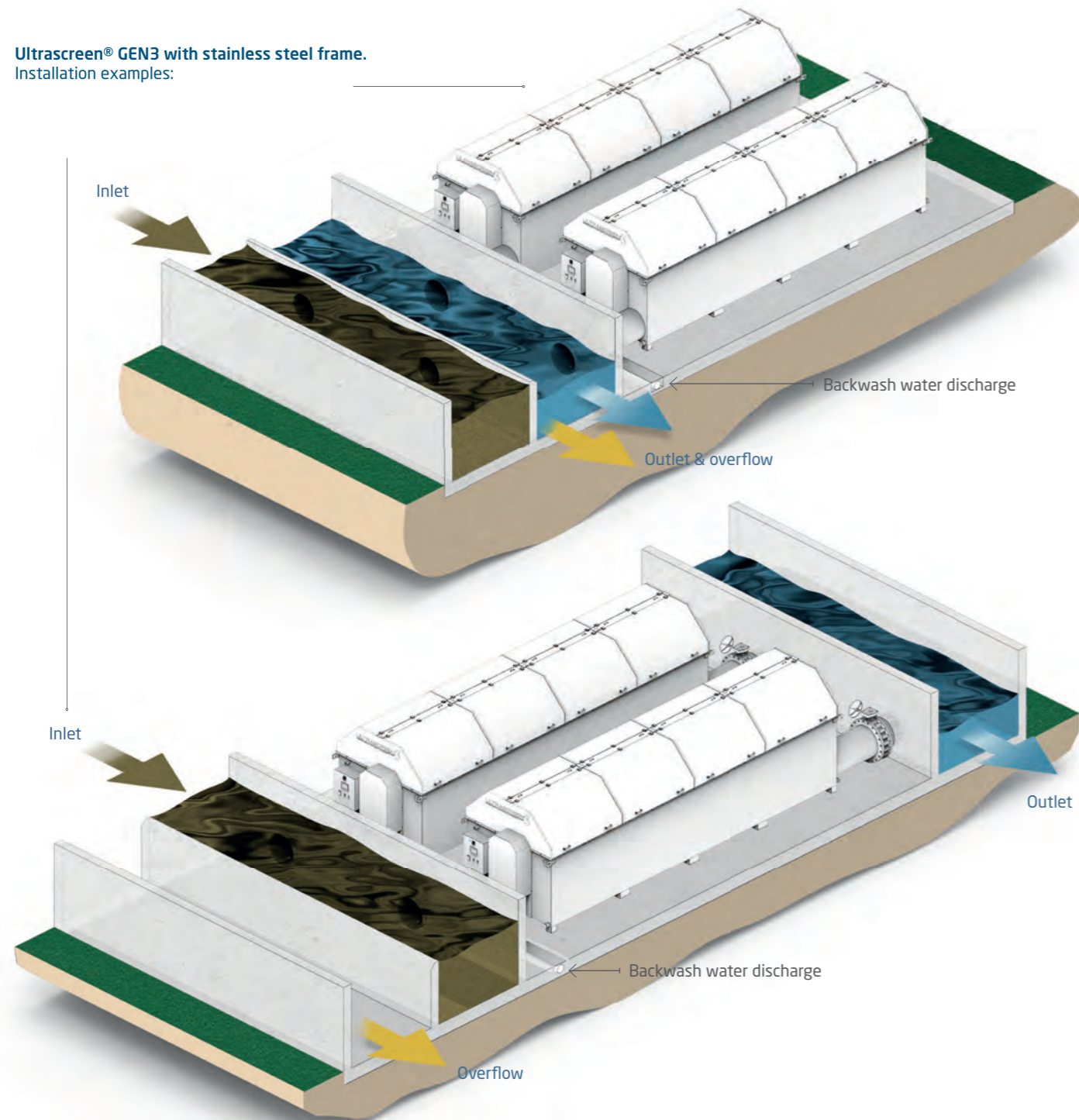

Ultrascreen® GEN3 in concrete tank.
Installation examples:

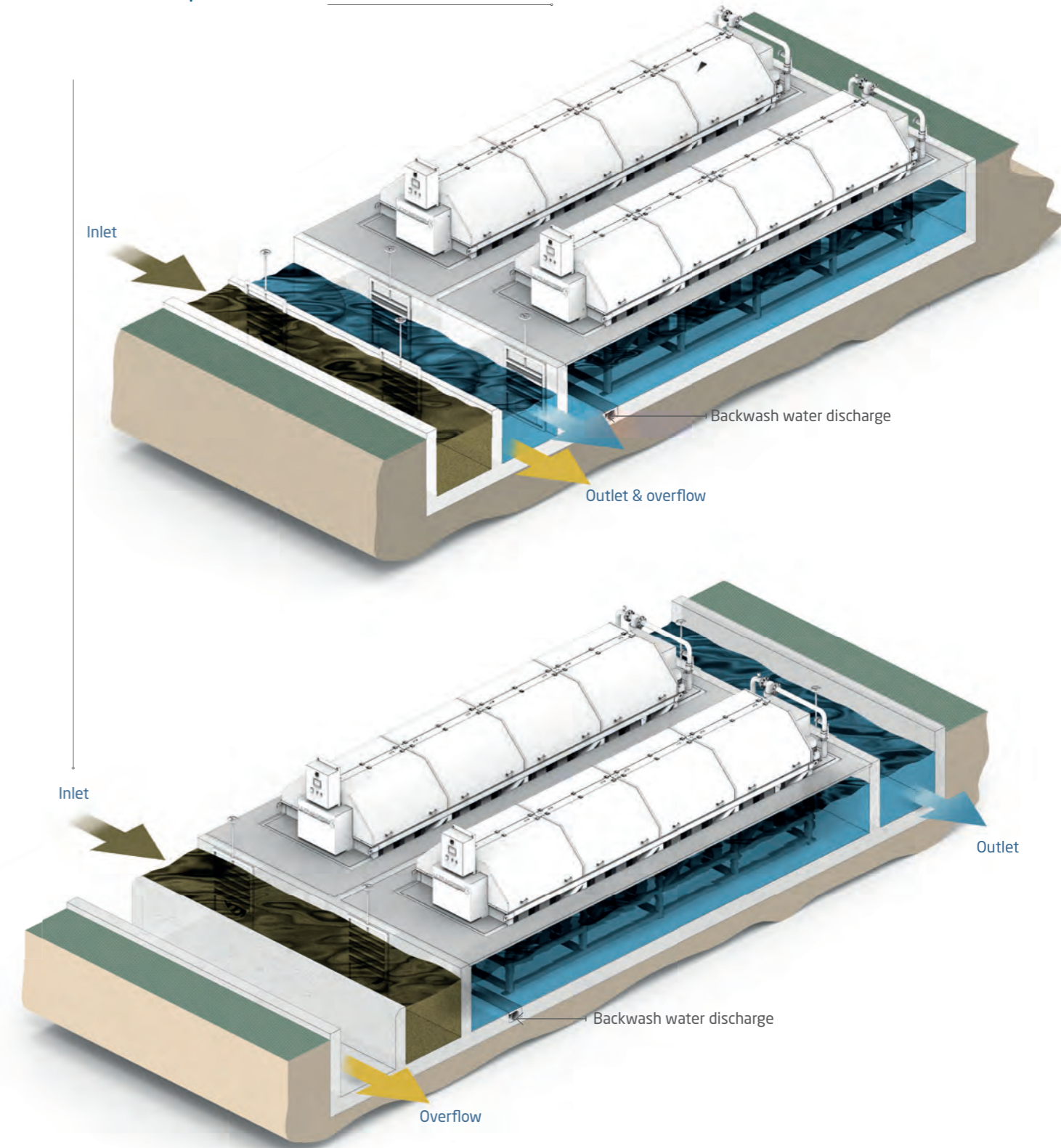

DIFFERENT FIELDS, SAME EFFICIENCY.

From the wastewater filtration, both in the municipal and the industrial field, to the aquaculture: these are the sectors where **Ultrascreen®** can be successfully used.

The variety of sectors in which Ultrascreen® is employed proves it extremely flexible: fields that are apparently apart from each other can use our technology and exploit all its advantages.



Municipal and industrial wastewater

Ultrascreen® treats and filters both municipal and industrial wastewaters.



- Total suspended solids lowering (TSS)
- Phosphorus lowering
- BOD and COD lowering
- Helminth eggs removal
- Water transmittance increase to advantage of the UV-C disinfection systems.

Municipal sector

- Primary water treatment
- Secondary/tertiary treatment
- Rainwater treatment
- Water filtration for water reuse
- Water filtration for potabilization

Industrial sector

- Industrial cycles process water filtration
- Industrial wastewater treatment
- Industrial water filtration for general reuse
- Cooling towers recirculating water filtration



Aquaculture

Ultrascreen® is ideal for all those companies that breed and produce aquatic organisms.

- Recirculating Aquaculture Systems (RAS)
- Intake water
- Effluent water
- Algae filtration
- River, lake and sea water filtration

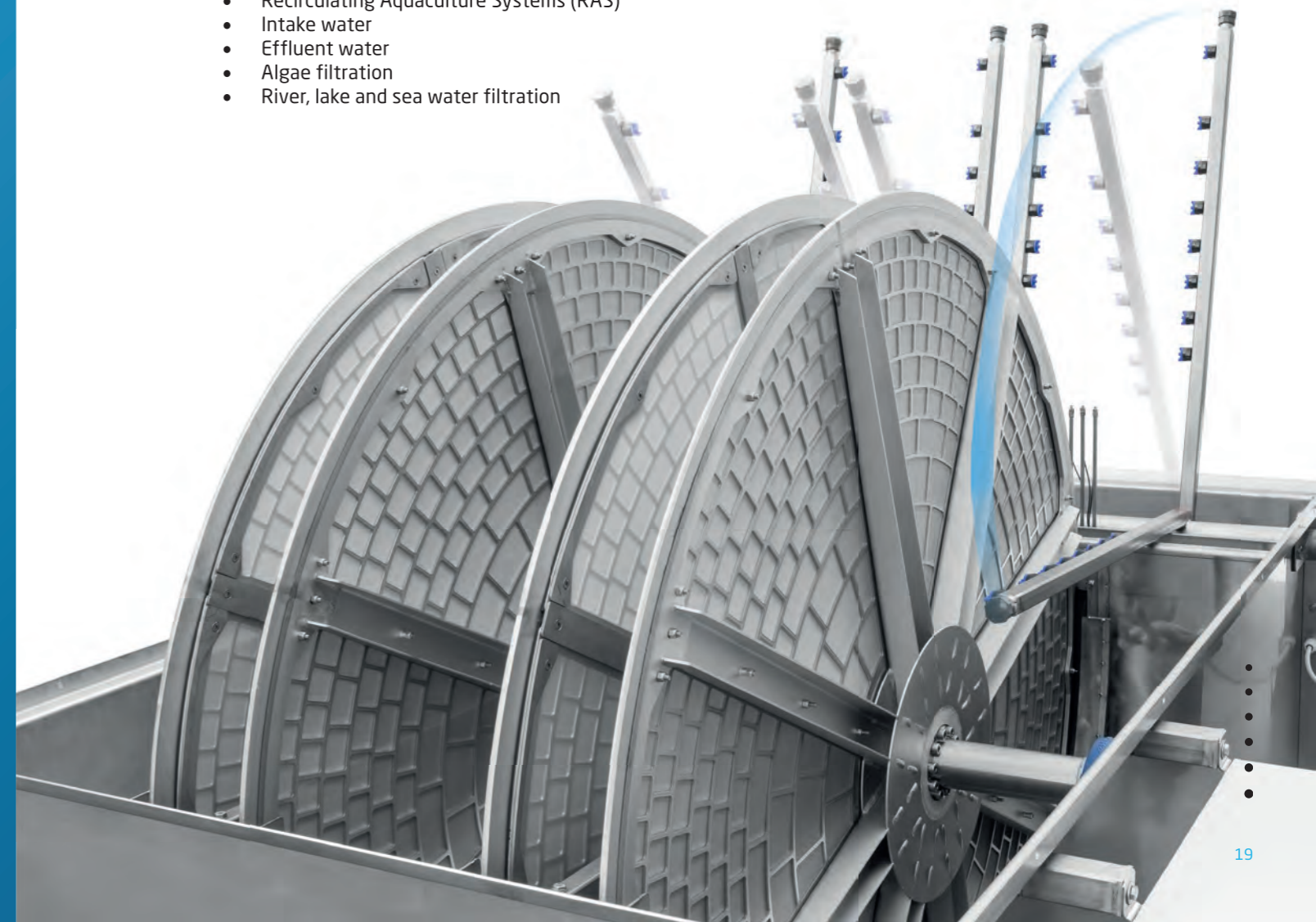

ULTRASCREEN®'S EXCELLENCE IS CERTIFIED.

Ultrascreen®'s uniqueness is known and recognized: European, American and Japanese certifications prove that.

The several patents and the prestigious international certifications ensure the customers to buy a unique machine and to choose a product which has passed all the authorization tests of the extremely strict environmental regulations before being marketed.

.....



Title 22 Certification - State of California USA
U.S. Patent
Japanese Patent
Italian and European Patent
Canadian Patent

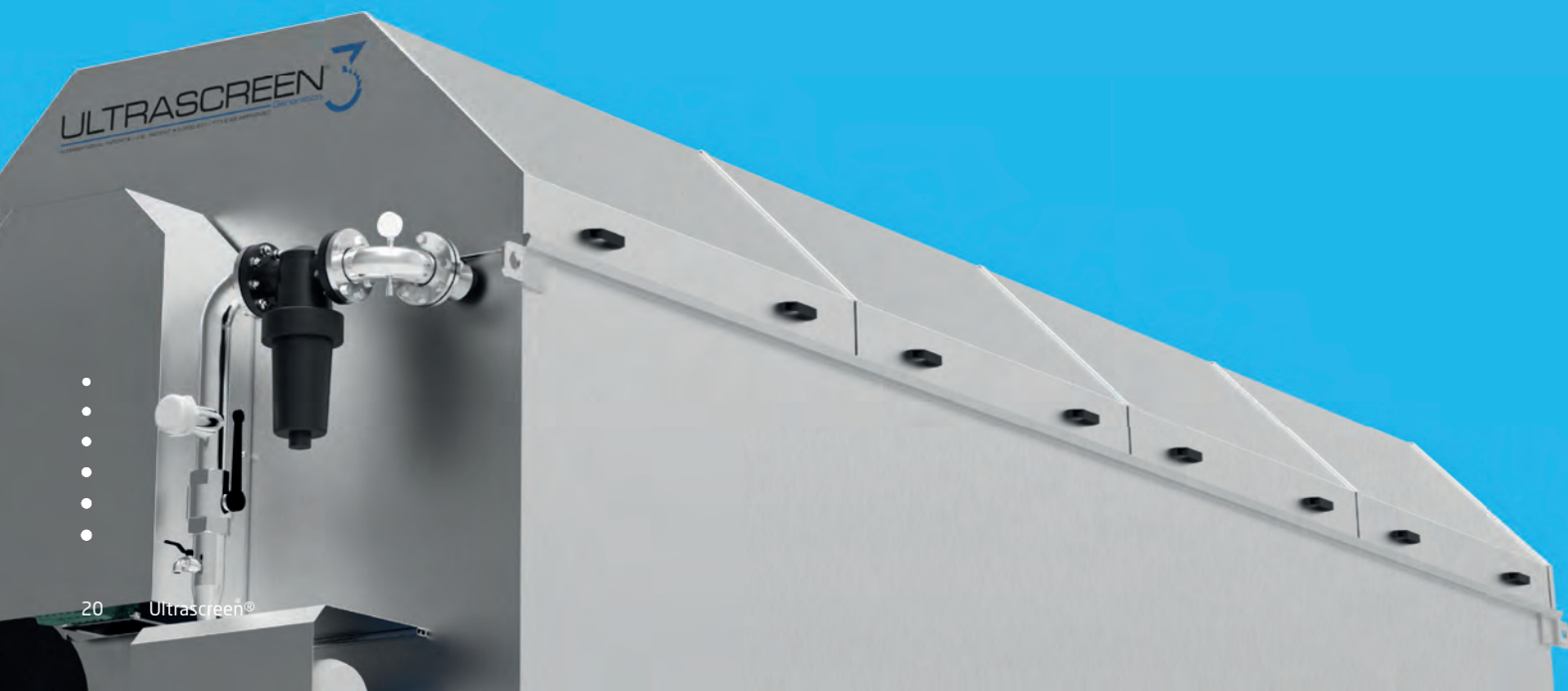

READY TO LISTEN, PREPARED TO ANSWER.

Clearness rises from dialogue: that's why we follow our customers from the consulting to the assistance with a highly customized service.

The relation with our customers doesn't end after the sale: our technicians know that and they will never forget it. That's the reason why they are always ready to listen, give information and solve problems. With just one phone call it is possible to get a professional and reliable advice, with prompt answers.

.....



QUALITY
IS EVIDENT

Some people are frightened by challenges, some others are thrilled by them.
Exceeding the limits is our signature.
Permanent and unmistakable.

In every project is held our bravery.
Our capacity to develop ideas out of the ordinary,
our determination to pursue extraordinary results,
our wish to improve ourselves,
our leaning towards experimentation.
Our identification marks.
Since the first day.

Steel is our raw material,
the element we mold to create solutions with a heart and a soul. Because behind every single product, there's always a team of people.
Men and women who combine their ability and passion every day to develop the most advanced technologies and achieve the most ambitious goals.

We could have let ourselves drifting.
Instead, we have decided to do something more:
build innovative systems, different and unique.
In every aspect. Because there are people who look forward and people who, like we do, look to infinity.

**Nuove Energie.
A name, a story,
a new conception of the future.**



Nuove Energie srl
Via della Meccanica 23/25
36100 Vicenza Italy

Tel +39 0444 963453
Fax +39 0444 960959

info@nuoveenergie.it
www.nuoveenergie.com