

Features and Benefits

- Protects components downstream by capturing potentially harmful ferrous particles

Specifications

Flow Rating:	35 gpm (130 L/min)
Element Replacement Part Number:	A-LF-1789
Element Change Clearance:	1.5" (40 mm)
Weight of KF3-SKB:	11.5 lbs (5.2 kg)

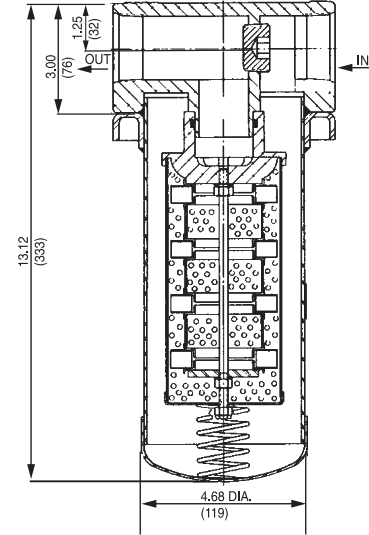

Applications



INDUSTRIAL



MOBILE VEHICLES

Filter Model Number Selection

How to Build a Valid Model Number for a Schroeder KF3-SKB:



Example: NOTE: One option per box

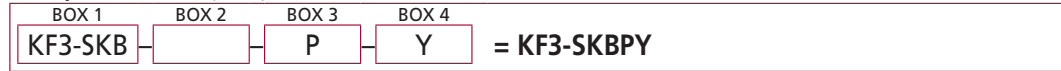

BOX 1	BOX 2	BOX 3	BOX 4
Filter Series	Seal Material	Porting	Dirt Alarm® Options
KF3-SKB	Omit = Buna N	P = 1/2" NPTF	Omit = None
			Visual = Vacuum guage
			Electrical = VS = Electrical Vacuum Switch
			VS1 = Heavy-Duty Vacuum Switch

NOTE:
Box 1. Element replacement part number: A-LF-1789.