

Top-Ported Pressure Filter

HS60



Features and Benefits

- Full flow reverse flow check valve diverts flow past the element in hydrostatic applications
- Top-ported design capable of handling 100 gpm flow
- Offered in SAE straight thread and flange porting
- Thread on bowl with drain plug for easy element service
- 6000 psi cyclic
- Certified for Offshore Standard DNVGL-OS-D101 "Marine and Machinery Systems and Equipment"
- Contact factory for higher flow applications

Model No. of filters in photograph is HS6013HZ3F24

100 gpm
380 L/min
6000 psi
415 bar



Applications

Flow Rating:	Up to 100 gpm (380 L/min)
Max. Operating Pressure:	6000 psi (415 bar) only for flange ported models
Min. Yield Pressure:	Contact factory
Rated Fatigue Pressure:	6000 psi (415 bar) (only with 4-bolt flange porting)
Temp. Range:	-20°F to 225°F (-29°C to 107°C)
Bypass Setting:	Cracking: 87 psi (5.9 bar)
Porting Head:	Ductile Iron
Element Case:	Steel
Weight of HS60-13H:	75 lbs. (34.2 kg)
Element Change Clearance:	4.0" (103 mm)

Filter Housing Specifications

- NF30
- NFS30
- YF30
- CFX30
- PLD
- DF40
- CF40
- PF40
- LC50
- RFS50
- RF60
- CF60
- CTF60
- VF60
- LW60
- KF30
- TF50
- KF50
- KC50
- MKF50
- KC65
- NOF30-05
- NOF50
- FOF60-03
- NMF30
- RMF60
- Cartridge Elements
- HS60**
- MHS60
- KFH50

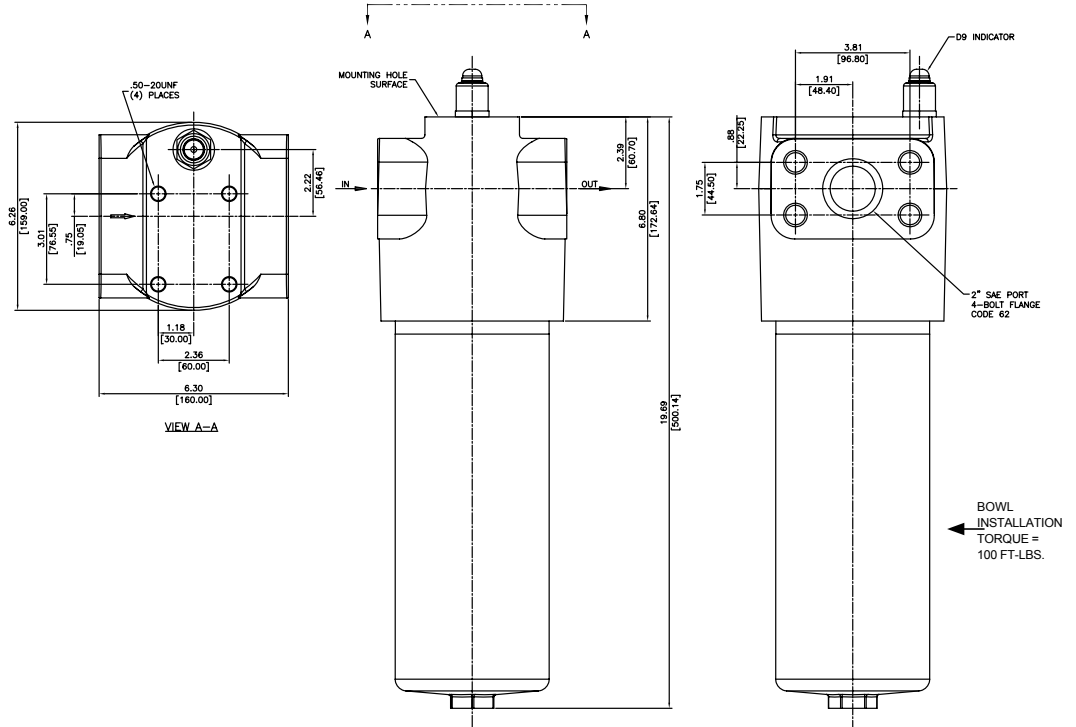

Metric dimensions in ().

Element Performance Information

Element	Filtration Ratio Per ISO 4572/NFPA T3.10.8.8 Using automated particle counter (APC) calibrated per ISO 4402			Filtration Ratio per ISO 16889 Using APC calibrated per ISO 11171	
	$\beta_x \geq 75$	$\beta_x \geq 100$	$\beta_x \geq 200$	$\beta_x(c) \geq 200$	$\beta_x(c) \geq 1000$
13HZ3/13HZX3	<1.0	<1.0	<2.0	<4.0	4.8
13HZ5/13HZX5	2.5	3.0	4.0	4.8	6.3
13HZ10/13HZX10	7.4	8.2	10.0	8.0	10.0
13HZ25/13HZX25	18.0	20.0	22.5	19.0	24.0

Dirt Holding Capacity

Element	DHC (gm)	Element	DHC (gm)
13HZ3	100.7	13HZX3	75.7
13HZ5	113.2	13HZX5	74.1
13HZ10	119.7	13HZX10	81.4
13HZ25	123.5	13HZX25	92.9

Element Collapse Rating: 290 psi (20 bar) for standard elements
3045 psi (210 bar) for high collapse (ZX) versions

Flow Direction: Outside In

Element Nominal Dimensions: 13HZ : 3.5" (90 mm) O.D. x 13" (325 mm) long

Top-Ported Pressure Filter

HS60

Type Fluid	Appropriate Schroeder Media
High Water Content	All Z-Media® (synthetic)
Invert Emulsions	10 and 25 µ Z-Media® (synthetic)
Water Glycols	3, 5, 10 and 25 µ Z-Media® (synthetic)
Phosphate Esters	All Z-Media® (synthetic) with H (EPR) seal designation

Fluid Compatibility

- NF30
- NFS30
- YF30
- CFX30
- PLD

Pressure	Element Series	Part No.	Element selections are predicated on the use of 150 SUS (32 cSt) petroleum based fluid and a 50 psi (3.4 bar) bypass valve.						
			0	20	40	60	80	100	
To 6000 psi (415 bar)	Z- Media®	13HZ3							
		13HZ5							
		13HZ10							
		13HZ25							
	Z- Media® (High Collapse)	13HZX3							
		13HZX5							
		13HZX10							
		13HZX25							
Flow	gpm	0	20	40	60	80	100		
	(L/min)	0	75	150	225	300	380		

Element Selection
Based on
Flow Rate

- DF40
- CF40
- PF40
- LC50
- RFS50
- RF60
- CF60
- CTF60
- VF60
- LW60

Shown above are the elements most commonly used in this housing.

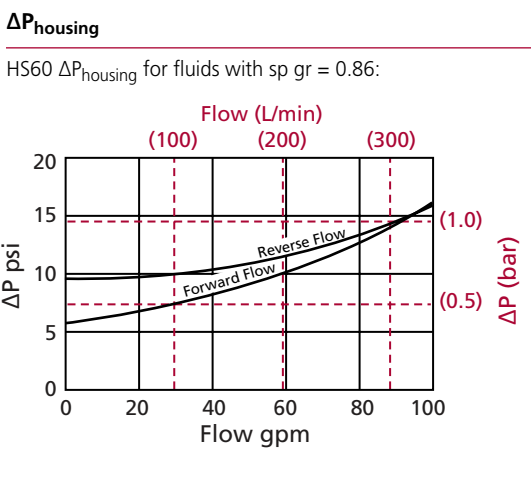

ΔP_{element}

ΔP_{element} = flow x element ΔP factor x viscosity factor

El. ΔP factors @ 141 SUS (30 cSt):

13HZ3	0.134	13HZX3	0.176
13HZ5	0.098	13HZX5	0.104
13HZ10	0.060	13HZX10	0.054
13HZ25	0.043	13HZX25	0.048

If working in units of bars & L/min, divide above factor by 54.9.

Viscosity factor: Divide viscosity by 141 SUS (30 cSt).

Pressure Drop Information
Based on
Flow Rate
and Viscosity

- KF30
- TF50
- KF50
- KC50
- MKF50
- KC65
- NOF30-05
- NOF50
- FOF60-03
- NMF30
- RMF60

sp gr = specific gravity

Sizing of elements should be based on element flow information provided in the Element Selection chart above.

ΔP_{filter} = ΔP_{housing} + ΔP_{element}

Exercise:
Determine ΔP at 85 gpm (320 L/min) for HS60... using 141 SUS (30 cSt) fluid.

Solution:

ΔP_{housing} = 13.5 psi [0.93 bar]

ΔP_{element} = 85 x .134 x (141÷141) = 11.39 psi
or
= [320 x (.134÷54.9) x (32÷32)] = .79 bar

ΔP_{total} = 13.5 + 11.39 = 24.89 psi
or
= [.93 + .79] = 1.71 bar

Cartridge
Elements

HS60

- MHS60
- KFH50

Filter Model Number Selection

How to Build a Valid Model Number for a Schroeder HS60:

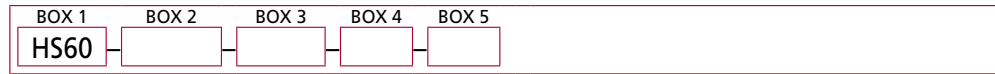

Example: NOTE: One option per box

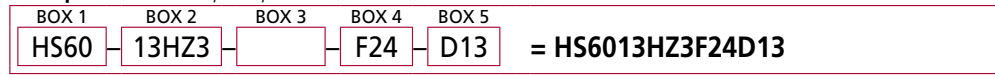

Filter Series
HS60
HSN60 (no bypass in forward flow)

Element Part Number
13HZ3 = 3 μ Excellement® Z-Media® (synthetic)
13HZ5 = 5 μ Excellement® Z-Media® (synthetic)
13HZ10 = 10 μ Excellement® Z-Media® (synthetic)
13HZ25 = 25 μ Excellement® Z-Media® (synthetic)
13HZX3 = 3 μ Excellement® Z-Media® (high collapse center tube)
13HZX5 = 5 μ Excellement® Z-Media® (high collapse center tube)
13HZX10 = 10 μ Excellement® Z-Media® (high collapse center tube)
13HZX25 = 25 μ Excellement® Z-Media® (high collapse center tube)

Seal Material
Omit = Buna N
V = Viton®
H = EPR

Porting Options
S24 = SAE-24
F24 = 1½" SAE 4-bolt flange Code 62
F32 = 2" SAE 4-bolt flange Code 62

Dirt Alarm® Options	
	Omit = None
Visual	D13 = Visual pop-up
Electrical	MS5SS = Electrical w/ 12 in. 18 gauge 4-conductor cable
	MS5SSLC = Low current MS5
	MS10SS = Electrical w/ DIN connector (male end only)
	MS10SSLC = Low current MS10
	MS11SS = Electrical w/ 12 ft. 4-conductor wire
	MS12SS = Electrical w/ 5 pin Brad Harrison connector (male end only)
	MS12SSLC = Low current MS12
	MS16SS = Electrical w/ weather-packed sealed connector
	MS16SSLC = Low current MS16
	MS17SSLC = Electrical w/ 4 pin Brad Harrison male connector
Electrical with Thermal Lockout	MS5SST = MS5 (see above) w/ thermal lockout
	MS5SSLCT = Low current MS5T
	MS10SST = MS10 (see above) w/ thermal lockout
	MS10SSLCT = Low current MS10T
	MS12SST = MS12 (see above) w/ thermal lockout
	MS12SSLCT = Low current MS12T
	MS16SST = MS16 (see above) w/ thermal lockout
	MS16SSLCT = Low current MS16T
Electrical Visual	MS13SS = Supplied w/ threaded connector & light
	MS14SS = Supplied w/ 5 pin Brad Harrison connector & light (male end)
Electrical Visual with Thermal Lockout	MS13SSDCT = MS13 (see above), direct current, w/ thermal lockout
	MS13SSDCLCT = Low current MS13DCT
	MS14SSDCT = MS14 (see above), direct current, w/ thermal lockout
	MS14SSDCLCT = Low current MS14DCT

NOTES:

Box 2. Replacement element part numbers are identical to contents of Boxes 2 and 3.

Box 3. Viton® is a registered trademark of DuPont Dow Elastomers.

Box 5. All Dirt Alarm® Indicators must be Stainless Steel. Standard indicator setting is 75 psi. For replacement indicators, contact the factory.