

Air Fusion Technology (Fixed Head)

AFTF



Features and Benefits

- Patent Pending In-tank filter design
- Lightweight and as part of a tank optimization package can reduce reservoir size
- Lock & Key Quality Protected, OEM Specific Interfaces available
- Superior de-aeration performance
- Fixed head connection. Lines stay connected during element changeouts

Si Part of Schroeder Industries' Energy Sustainability Initiative

40 gpm
151 L/min
100 psi
7 bar

IRF

TF1

KF3

KL3

LF1

MLF1

RLD

GRTB

MTA

MTB

ZT

AFT

AFTF

KFT

RT

RTI

LRT

ART

BRT

TRT

BFT

QT

KTK

LTK

MRT

Accessories
For Tank-
Mounted
Filters

PAF1

MAF1

MF2

Flow Rating:	40 gpm (151 L/min)
Max. Operating Pressure:	100 psi (7 bar)
Min. Yield Pressure:	350 psi (24 bar)
Rated Fatigue Pressure:	100 psi (7 bar)
Temp. Range:	-20°F to 225°F (-29°C to 107°C)
Bypass Setting:	Cracking: 25 psi (1.7 bar)
Element Change Clearance:	4LK = 5.28" [134mm] 8LK = 8.62" [219mm] 12LK = 11.96" [304mm] 16LK = 15.30" [389mm]
Element Case:	12 elements

**Filter
Housing
Specifications**

Type Fluid	Appropriate Schroeder Media
Petroleum Based Fluids	Z-Media [®] and ASP [®] media (synthetic)
High Water Content	All Z-Media [®] and ASP [®] media (synthetic)
Invert Emulsions	10 and 25 μ Z-Media [®] and 10 μ ASP [®] media (synthetic)
Water Glycols	3, 5, 10 and 25 μ Z-Media [®] and all ASP [®] media (synthetic)
Phosphate Esters	All Z-Media [®] (synthetic) with H (EPR) seal designation and all ASP [®] media (synthetic)

**Fluid
Compatibility**

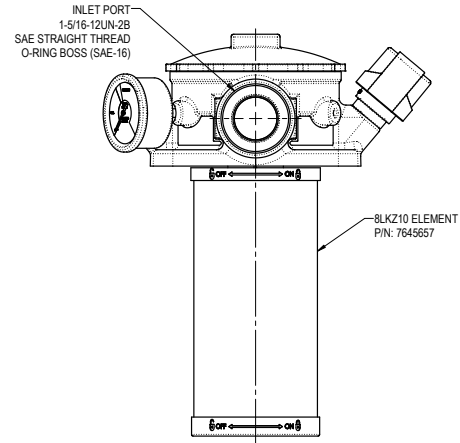
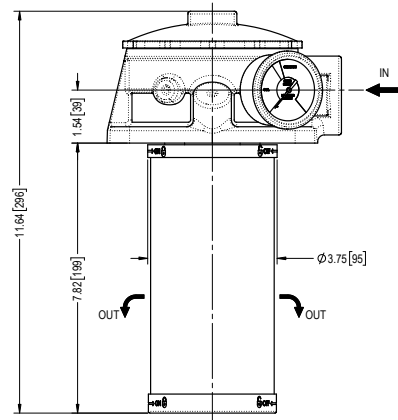
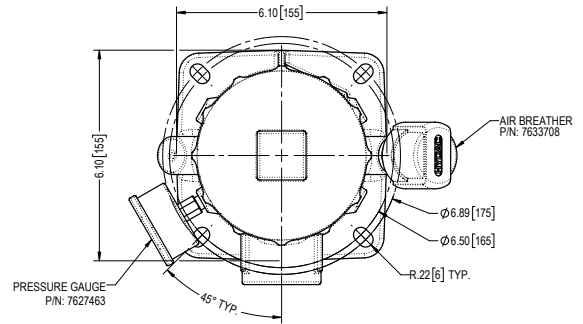

Metric dimensions in (mm).

Element Performance Information & Dirt Holding Capacity

Element	Filtration Ratio Per ISO 4572/NFPA T3.10.8.8 Using automated particle counter (APC) calibrated per ISO 4402			Filtration Ratio wrt ISO 16889 Using APC calibrated per ISO 11171	
	$\beta_x \geq 75$	$\beta_x \geq 100$	$\beta_x \geq 200$	$\beta_x(c) \geq 200$	$\beta_x(c) \geq 1000$
4LKZ3, 8LKZ3 12LKZ3, 16LKZ3	<1.0	<1.0	<2.0	<4.0	4.8
4LKZ5, 8LKZ5 12LKZ5, 16LKZ5	2.5	3.0	4.0	4.8	6.3
4LKZ10, 8LKZ10 12LKZ10, 16LKZ10	7.4	8.2	4.0	8.0	10.0
4LKZ25, 8LKZ25 12LKZ25, 16LKZ25	18.0	20.0	22.5	19.0	24.0

Element	DHC (gm)	Element	DHC (gm)	Element	DHC (gm)	Element	DHC (gm)
4LKZ3	8	8LKZ3	16	12LKZ3	23	16LKZ3	30
4LKZ5	9	8LKZ5	18	12LKZ5	26	16LKZ5	33
4LKZ10	11	8LKZ10	22	12LKZ10	32	16LKZ10	41
4LKZ25	18	8LKZ25	36	12LKZ25	52	16LKZ25	69

Element Burst Pressure: 86 psi (6 bar)

Flow Direction: Inside Out

Element Nominal Dimensions: 4LKZ: 3.71" (94.23 mm) O.D. x 4.49" (114.05 mm) long
 8LKZ: 3.71" (94.23 mm) O.D. x 7.84" (199.14 mm) long
 12LKZ: 3.71" (94.23 mm) O.D. x 11.18" (283.97 mm) long
 16LKZ: 3.71" (94.23 mm) O.D. x 14.52" (368.81 mm) long

$\Delta P_{\text{housing}}$

AFT $\Delta P_{\text{housing}}$ for fluids with sp gr (specific gravity) = 0.86:

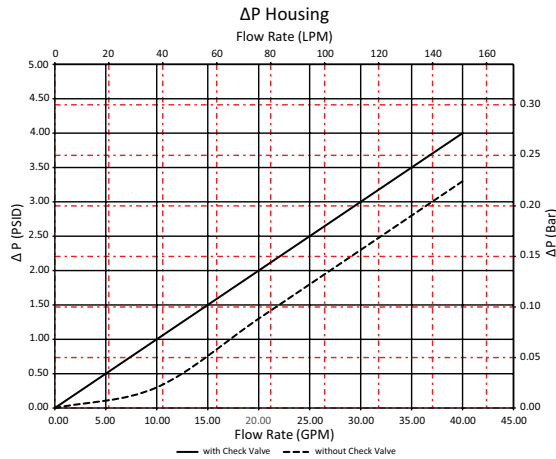

Pressure Drop Information Based on Flow Rate and Viscosity

$\Delta P_{\text{element}}$

4LKZ

Element Pressure Drop versus Flow Rate at 32 cSt (150 SUS)

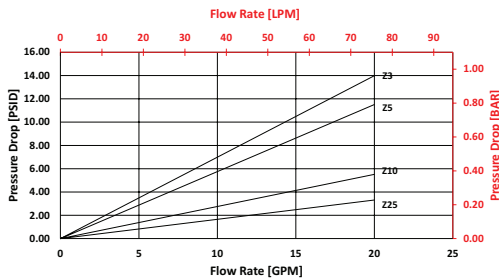

8LKZ

Element Pressure Drop versus Flow Rate at 32 cSt (150 SUS)

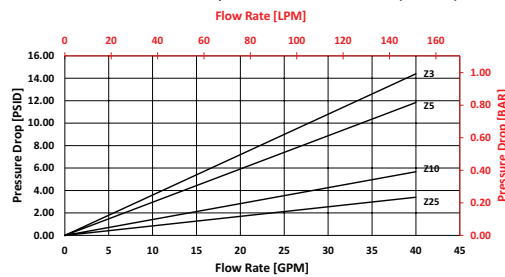

12LKZ

Element Pressure Drop versus Flow Rate at 32 cSt (150 SUS)

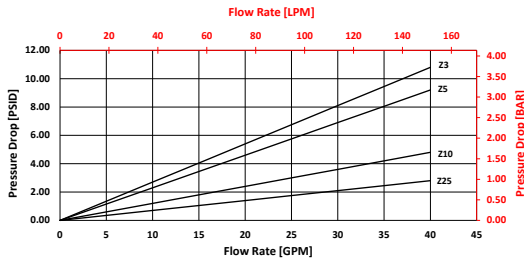

16LKZ

Element Pressure Drop versus Flow Rate at 32 cSt (150 SUS)

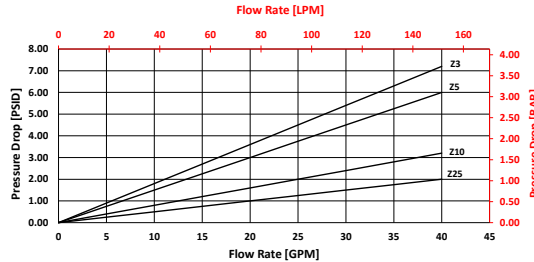

Note: Additional Pressured Drop information available upon request

$$\Delta P_{\text{filter}} = \Delta P_{\text{housing}} + (\Delta P_{\text{element}} * V_f)$$

Exercise:

Determine ΔP_{filter} at 10 gpm (37.9 L/min) for AFT8LKZ10L16Y2 using 160 SUS (34 cSt) fluid.

Use the housing pressure curve to determine $\Delta P_{\text{housing}}$ at 10 gpm. In this case, $\Delta P_{\text{housing}}$ is 1.5 psi (.10 bar) on the graph for the AFT housing.

Use the element pressure curve to determine $\Delta P_{\text{element}}$ at 10 gpm. In this case, $\Delta P_{\text{element}}$ is 1.4 psi (.10 bar) according to the graph for the 8LKZ10 element.

Because the viscosity in this sample is 160 SUS (34 cSt), we determine the Viscosity Factor (V_f) by dividing the Operating Fluid Viscosity with the Standard Viscosity of 150 SUS (32 cSt). To best determine your Operating Fluid Viscosity, please reference the chart in Appendix D.

Finally, the overall filter pressure differential, ΔP_{filter} , is calculated by adding $\Delta P_{\text{housing}}$ with the true element pressure differential, ($\Delta P_{\text{element}} * V_f$). The $\Delta P_{\text{element}}$ from the graph has to be multiplied by the viscosity factor to get the true pressure differential across the element.

Solution:

$$\Delta P_{\text{housing}} = 1.5 \text{ psi } [.10 \text{ bar}] \mid \Delta P_{\text{element}} = 1.4 \text{ psi } [.10 \text{ bar}]$$

$$V_f = 160 \text{ SUS (34 cSt)} / 150 \text{ SUS (32 cSt)} = 1.1$$

$$\Delta P_{\text{filter}} = 1.5 \text{ psi} + (1.4 \text{ psi} * 1.1) = 3.0 \text{ psi}$$

OR

$$\Delta P_{\text{filter}} = .10 \text{ bar} + (.10 \text{ bar} * 1.1) = .21 \text{ bar}$$

Filter Model Number Selection

How to Build a Valid Model Number for a Schroeder AFTF:

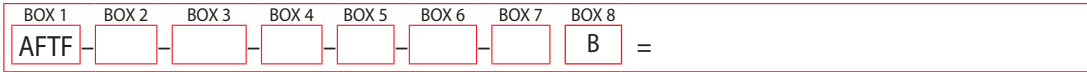

Example: NOTE: One option per box

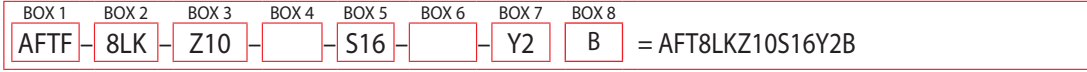

BOX 1	BOX 2	BOX 3	BOX 4
Filter Series	Element	Media	Seal
AFTF Air Fusion Technology Fixed Head Filter	4LK = 4" Element 8LK = 8" Element 12LK = 12" Element 16LK = 16" Element	Z3 = 3 micron Z media Z5 = 5 micron Z media Z10 = 10 micron Z media Z25 = 25 micron Z media	Omit = Buna V = Viton

BOX 5	BOX 6	BOX 7
Porting	Bypass	Gauge Port Option
S16 = SAE 16	Omit = 25 psi	N = Plugged Y2 = Tricolor visual indicator (Back Mounted) ES = Electric Switch ES1 = Heavy Duty Electric Switch ES2 = Electrical Switch with Deutsch Connector

BOX 8
Breather
B = Breather

NOTES:

- Box 2. Replacement element part numbers are a combination of Boxes 2, 3 and 4. Example: 8LKZ25V
- Box 4. Viton® is a registered trademark of DuPont Dow Elastomers. All elements for this filter are supplied with Viton® seals.